

**EXTRAORDINARY GAZETTE**



**THE SOUTH AUSTRALIAN  
GOVERNMENT GAZETTE**

---

**PUBLISHED BY AUTHORITY**

---

**ALL PUBLIC ACTS appearing in this GAZETTE are to be considered official, and obeyed as such**

---

**ADELAIDE, THURSDAY, 11 NOVEMBER 1999**

---

**CONTENTS**

**REGULATIONS**

Road Traffic Act 1961—	
(No. 218 of 1999).....	1631
(No. 219 of 1999).....	1643

---

## FAXING COPY?

IF you fax copy to Riverside 2000, for inclusion in the *Government Gazette*, there is **no need** to send a Confirmation Copy to us as well.

This creates confusion and may well result in your notice being printed **twice**.

Please use the following fax number:

Fax transmission: (08) 8207 1040

Phone Inquiries: (08) 8207 1045

Please include a contact person, phone number and order number so that we can phone back with any queries we may have regarding the fax copy.

**NOTE: Closing time for lodging new copy (either fax or hard copy) is 4 p.m. on Tuesday preceding the day of publication.**

---

# REGULATIONS UNDER THE ROAD TRAFFIC ACT 1961

No. 218 of 1999

*At the Executive Council Office at Adelaide 11 November 1999*

PURSUANT to the *Road Traffic Act 1961* and with the advice and consent of the Executive Council, I make the following regulations.

E. J. NEAL Governor

PURSUANT to section 10AA(2) of the *Subordinate Legislation Act 1978*, I certify that, in my opinion, it is necessary or appropriate that the following regulations come into operation as set out below.

DIANA LAIDLAW Minister for Transport and Urban Planning

## CONTENTS

1	Citation
2	Commencement
3	Interpretation
4	References to rules
5	Words and expressions have same meanings as in Rules
6	Prescribed provisions for purposes of ss. 35, 174A, 174B, 174C and 174D of Act
7	General power of Minister to grant exemptions
8	Special provisions relating to school zones
9	Road trains and road train areas
10	Bicycles permitted in bus lanes
11	Speed past rear of stopped trams
12	Taxis not permitted to stop on clearways
13	Vehicles (other than public buses or trucks) permitted to stop in loading zones
14	Permits for permit zones
15	Vehicles permitted to stop on paths, dividing strips and nature strips
16	Structures declared to be public post boxes
17	Permitting heavy or long vehicles to stop in built-up areas for longer than one hour
18	Period for which drivers with disabilities permitted to park
19	Parking and parking ticket-vending machines or parking meters
20	Exemption from requirements relating to making motor vehicles secure
21	Lights to be fitted to vehicles
22	Dangerous goods and placard loads and towing of vehicles at night etc.
23	Operation of hazard warning lights if children being dropped off or picked up
24	Areas on which wheeled recreational devices and toys prohibited
25	Riders 12 years old or older not to ride on footpath
26	Sikhs exempt from wearing bicycle helmets
27	Approved child restraints
28	Exemptions from wearing seatbelts
29	Approved motor bike helmets
30	Certain crashes required to be reported to police

## Regulation 1

---

- 31 Information required to be reported to police about crashes
- 32 Drivers permitted on paths
- 33 Drivers permitted on nature strips
- 34 Exemptions for certain tests and work
- 35 Vehicles that may be towed away etc.
- 36 Exemptions for postal vehicles
- 37 Approved bicycle helmets
- 38 Authorised persons
- 39 Emergency workers
- 40 Hazard warning lights
- 41 Mechanical signalling devices
- 42 Oversize vehicles
- 43 Parking permits for people with disabilities
- 44 Police officers
- 45 Portable warning triangles
- 46 Postal workers
- 47 Public buses
- 48 Public holidays
- 49 Taxis
- 50 Penalties for offences against Rules
- 51 Evidentiary provisions
- 52 Transitional provisions

### SCHEDULE 1

#### *Roads on which Wheeled Recreational Devices and Toys Prohibited Regulation 22*

---

#### **1 Citation**

These regulations may be cited as the *Road Traffic (Road Rules—Ancillary and Miscellaneous Provisions) Regulations 1999*.

#### **2 Commencement**

These regulations will come into operation on 1 December 1999.

#### **3 Interpretation**

In these regulations —

“**the Act**” means the *Road Traffic Act 1961*;

“**the Rules**” means the *Australian Road Rules*.

#### **4 References to rules**

In these regulations, a reference to a specified rule is a reference to the provision so specified of the Rules.

#### **5 Words and expressions have same meanings as in Rules**

Words and expressions used in the Rules and in these regulations have the same respective meanings as in the Rules, except to the extent that the context or subject matter otherwise requires.

## 6 Prescribed provisions for purposes of ss. 35, 174A, 174B, 174C and 174D of Act

- (1) For the purposes of the following provisions of the Act:
- (a) section 35 (Inspectors);
  - (b) section 174A (Liability of vehicle owners and expiation of certain offences);
  - (c) section 174B (Further offence for continued parking contravention);
  - (d) section 174D (Proceedings for certain offences may only be taken by certain officers or with certain approvals),

the provisions of Part 12 of the Rules (Restrictions on stopping and parking) are prescribed provisions.

- (2) For the purposes of section 174C of the Act (Council may grant exemptions from certain provisions), the following are prescribed provisions:
- (a) the provisions of Part 8, Division 3 of the Rules (Signs for trucks, buses and other large vehicles);
  - (b) the provisions of Part 12, Division 2 of the Rules (No stopping and no parking signs and road markings);
  - (c) the provisions of Part 12, Division 5 of the Rules (Stopping in zones for particular vehicles);
  - (d) rule 195 (Stopping at or near a bus stop);
  - (e) rule 200 (Stopping on roads—heavy and long vehicles);
  - (f) rule 205 (Parking for longer than indicated);
  - (g) rule 207 (Parking where fees are payable).

## 7 General power of Minister to grant exemptions

- (1) The Minister may, by notice in writing or notice published in the *Gazette*, exempt—
- (a) a person or class of persons; or
  - (b) a vehicle or class of vehicles,
- from a specified provision of the Rules, unconditionally or subject to specified conditions.
- (2) The Minister may, by notice in writing or notice published in the *Gazette*, vary or revoke an exemption under this regulation.

## 8 Special provisions relating to school zones

- (1) For the purposes of rule 23 (Speed-limit in a school zone), if the words “WHEN CHILDREN PRESENT” are displayed on or with a school zone sign, the words are to be taken to mean that the speed limit displayed on the sign applies when a child is present in the school zone.
- (2) In proceedings for an offence against rule 20 (Obeying the speed-limit) relating to a school zone, if it is proved that a person was present in the school zone area and evidence is given that the person appeared to the witness to be a child, it will be presumed that person was a child in the absence of proof to the contrary.
- (3) In this regulation—
- “**child**” means a person under the age of 18 years, and includes a student of any age in school uniform.

## 9 Road trains and road train areas

For the purposes of rule 127(2) (Keeping a minimum distance between long vehicles)—

- (a) a combination that is a road train as defined in the *Road Traffic (Mass and Loading Requirements) Regulations 1999* is a road train for the Rules; and
- (b) an area where road trains may be driven under the *Road Traffic (Miscellaneous) Regulations 1999* is a road train area.

## 10 Bicycles permitted in bus lanes

For the purposes of rule 158(2) (Exceptions to driving in special purpose lanes etc), the rider of a bicycle is permitted to ride in a bus lane.

## 11 Speed past rear of stopped trams

- (1) For the purposes of rule 163(3) (Driving past the rear of a stopped tram), the maximum speed at which a driver may drive past a tram in accordance with that rule is the speed limit that would otherwise apply to the driver for the length of road.
- (2) For the purposes of rule 164(4) (Giving way to pedestrians crossing the road near a stopped tram), the maximum speed at which a driver may drive past a tram in accordance with that rule is the speed limit that would otherwise apply to the driver for the length of road.

## 12 Taxis not permitted to stop on clearways

For the purposes of rule 176(3) (Stopping on a clearway), the driver of a taxi is prohibited from stopping on a length of road to which a clearway sign applies.

## 13 Vehicles (other than public buses or trucks) permitted to stop in loading zones

- (1) For the purposes of rule 179(1) (Stopping in a loading zone)—
  - (a) a commercial vehicle that is dropping off, or picking up, goods is permitted to stop in a loading zone; and
  - (b) a vehicle, other than a commercial vehicle, is permitted to stop in a loading zone if the vehicle is dropping off, or picking up, goods that are difficult to handle because of their weight or size; and
  - (c) a taxi that is dropping off, or (having been hailed or summoned for the purpose) picking up, passengers is permitted to stop in a loading zone provided that the driver does not leave the taxi unattended.
- (2) In this regulation—

“**commercial vehicle**” means a motor vehicle constructed solely or mainly for the carriage of goods (including a vehicle of the kind commonly called a utility, but excluding a vehicle of the kind commonly called a station wagon or station sedan).
- (3) For the purposes of this regulation, a driver leaves a taxi **unattended** if the driver leaves the taxi so the driver is over 3 metres from the closest point of the taxi.

## 14 Permits for permit zones

- (1) This regulation applies for the purposes of rule 185 (Stopping in a permit zone) if a council has installed, or determined that it will install, permit zone signs to establish a permit zone in its area.

- (2) The council may determine—
- (a) the class of permits required for vehicles to stop in the permit zone; and
  - (b) the persons entitled to such permits; and
  - (c) any fees to be paid for such permits; and
  - (d) the conditions to which the permits will be subject (which may include conditions as to the period for which such permits remain in force and conditions as to the display of permits in vehicles),
- and may vary any such determination.
- (3) The council may issue permits in respect of the permit zone to persons entitled to them, on payment of the fee (if any), and subject to the conditions, determined by the council.
- (4) A permit issued by the council and in force in respect of the permit zone permits a vehicle to stop in the permit zone subject to the conditions of the permit.

### 15 Vehicles permitted to stop on paths, dividing strips and nature strips

- (1) For the purposes of rule 197(1) (Stopping on a path, dividing strip or nature strip), the following drivers are permitted to stop on a path, dividing strip or nature strip:
- (a) a driver engaged in duties for the Police Security Services Division of the South Australian Police Department;
  - (b) the driver of a motorised wheelchair;
  - (c) the rider of a motor bike delivering postal articles in the course of duties as a postal worker.
- (2) For the purposes of rule 197(1), a driver is permitted to stop on a footpath if the driver is crossing the path to enter a road-related area or adjacent land and is required to open a gate or take some other action to enter the area or land.

### 16 Structures declared to be public post boxes

For the purposes of rule 199 (Stopping near a post box), post boxes maintained by Australia Post on road-related areas are public post boxes.

### 17 Permitting heavy or long vehicles to stop in built-up areas for longer than one hour

For the purposes of rule 200(2) (Stopping on roads—heavy and long vehicles), the driver of a heavy or long vehicle is permitted to stop on a road for longer than one hour if the vehicle is dropping off, or picking up, goods and continues to stop there for no longer than is necessary to complete that task.

Note: A council may grant an exemption from rule 200 under section 174C of the Act.

### 18 Period for which drivers with disabilities permitted to park

For the purposes of rule 206(2) (Time extension for people with disabilities), a driver to whom that rule applies is permitted to park on a length of road, or in an area, to which a permissive parking sign applies for—

- (a) twice the period indicated on the sign; or
- (b) the period indicated on the sign and a further 90 minutes,

whichever is the longer.

Note: A council may grant an exemption from rule 205 (Parking for longer than indicated) under section 174C of the Act.

**19 Parking and parking ticket-vending machines or parking meters**

- (1) For the purposes of rule 207(1) (Parking where fees are payable), if the word "TICKET" is displayed on a permissive parking sign, the word is to be taken to indicate that a fee is payable by buying a ticket through the operation of a parking ticket-vending machine.
- (2) For the purposes of rule 207(2), if a council has installed, or determined that it will install, permissive parking signs to apply to a length of road or an area, the council may determine fees that will be payable for parking in the length of road or the area by the operation of parking ticket-vending machines or parking meters installed or to be installed in or near the length of road or area, and may vary such fees.
- (3) For the purposes of rule 207(2), the driver does not pay the fee payable for parking on the length of road, or in the area, in accordance with that rule unless the driver, on first stopping the vehicle—
  - (a) if the fee is to be paid by buying a ticket—promptly proceeds to a parking ticket-vending machine in the length of road or the area, obtains the ticket and deals with the ticket in accordance with the instructions on or with the ticket-vending machine; or
  - (b) if the fee is to be paid by putting money into a parking meter—promptly proceeds to the parking meter for the place where the vehicle is parked and puts money into the meter in accordance with the instructions on or with the meter.

**20 Exemption from requirements relating to making motor vehicles secure**

Drivers in South Australia are exempt from rule 213 (Making a motor vehicle secure).

**21 Lights to be fitted to vehicles**

For the purposes of rule 215(4) (Using lights when driving at night or in hazardous weather conditions) and rule 220(3) (Using lights on vehicles that are stopped), the lights required to be fitted to a vehicle are those required to be fitted to it under the *Road Traffic (Vehicle Standards) Rules 1999*.

**22 Dangerous goods and placard loads and towing of vehicles at night etc.**

For the purposes of rule 216 (Towing a vehicle at night or in hazardous weather conditions), "dangerous goods" and "placard load" have the respective meanings given to those terms by the Code as defined in the *Dangerous Substances Regulations 1998*.

**23 Operation of hazard warning lights if children being dropped off or picked up**

For the purposes of rule 221 (Using hazard warning lights), a driver is permitted to operate hazard warning lights on a bus carrying children when the vehicle stops to drop off or pick up a child.

**24 Areas on which wheeled recreational devices and toys prohibited**

- (1) For the purposes of rule 240(2) and (3) (Wheeled recreational devices and toys not to be used on certain roads), wheeled recreational devices and wheeled toys are prohibited on an area specified in Schedule 1.
- (2) For the purposes of rule 240(2), wheeled recreational devices are prohibited on a length of footpath to which a *no wheeled recreational devices sign* applies.



- (3) A *no wheeled recreational devices sign* applies to a length of footpath beginning at the sign and ending at the nearer of the following:
- an *end no wheeled recreational devices sign*;
  - the end of the footpath.
- (4) Part 20 of the Rules applies in relation to a sign referred to in subregulation (1) or (2) as if this regulation (including the diagrams below) formed part of the Rules.

No wheeled recreational devices sign



End no wheeled recreational devices sign



- (5) For the purposes of rule 240(2) and (3), wheeled recreational devices and wheeled toys are prohibited on all roads at night or in hazardous weather conditions causing reduced visibility.

## 25 Riders 12 years old or older not to ride on footpath

For the purposes of rule 250(1) (Riding on a footpath or shared path), the rider of a bicycle who is 12 years old or older must not ride on a footpath.

## 26 Sikhs exempt from wearing bicycle helmets

For the purposes of rule 256(1) and (2) (Bicycle helmets), a person of the Sikh religion who is wearing a turban is exempt from wearing a bicycle helmet.

## 27 Approved child restraints

For the purposes of rule 266 (Wearing of seatbelts by passengers under 16 years old), child restraints are approved if approved under the *Road Traffic (Miscellaneous) Regulations 1999*.

## 28 Exemptions from wearing seatbelts

- (1) For the purposes of rule 267(1) (Exemptions from wearing seatbelts), a person is exempt from wearing a seat belt if—
- the vehicle is a historic vehicle (as defined in schedule 1 of the *Motor Vehicles Regulations 1996*) that is registered under section 25 of the *Motor Vehicles Act 1959* and being driven in accordance with the conditions of that registration as prescribed in that schedule; or
  - the vehicle is being used on behalf of the Crown for transporting prisoners or other persons in lawful custody.
- (2) For the purposes of rule 267(3), a certificate stating that a specified person is not required to wear a seatbelt, indefinitely or for a specified period, may be issued—
- by the Minister on any ground the Minister considers appropriate; or
  - by a medical practitioner on the ground of physical disability or any medical ground.

**29 Approved motor bike helmets**

For the purposes of rule 270 (Wearing motor bike helmets), helmets are approved motor bike helmets if approved for motor bike riders under the *Road Traffic (Miscellaneous) Regulations 1999*.

**30 Certain crashes required to be reported to police**

For the purposes of rule 287(3) (Duties of a driver involved in a crash), a crash is required to be reported to a police officer by a driver involved in the crash (or the driver's representative) if real or personal property (other than an animal) is destroyed or damaged except where—

- (a) the only property destroyed or damaged is property owned by the driver; or
- (b) a fair estimate of the cost of making good the damage to property is not more than \$1 000.

**31 Information required to be reported to police about crashes**

For the purposes of rule 287(4) (Duties of a driver involved in a crash) the information required to be given to a police officer about a crash includes—

- (a) the day, the time and the place of the crash; and
- (b) details of other drivers and vehicles involved in the crash; and
- (c) details of injuries and damage resulting from the crash; and
- (d) except where the driver objects to providing the information on the ground that it might incriminate him or her of an offence, details of vehicle speeds and positions before and at the time of impact.

**32 Drivers permitted on paths**

For the purposes of rule 288 (Driving on a path), a driver engaged in duties for the Police Security Services Division of the South Australian Police Department is permitted to drive on a path.

**33 Drivers permitted on nature strips**

For the purposes of rule 289(1) (Driving on a nature strip), a driver engaged in duties for the Police Security Services Division of the South Australian Police Department is permitted to drive on a nature strip.

**34 Exemptions for certain tests and work**

For the purposes of rule 310(3) and (4) (Exemption for road workers etc.), the Minister may, by notice in writing or notice published in the *Gazette*, authorise speed zoning tests, or installation or maintenance work or traffic surveys, subject to specified conditions.

**35 Vehicles that may be towed away etc.**

Rule 312 (Exemption for tow truck drivers) applies to (in addition to the vehicles referred to in rule 312(3)(a) and (b))—

- (a) a vehicle that the driver is authorised to remove under section 86 of the Act, section 26E of the *Highways Act 1926*, section 748b or 748c of the *Local Government Act 1934*, section 237 of the *Local Government Act 1999*, section 27 of the *South Australian Motor Sport Act 1984* or section 79B of the *Summary Offences Act 1953*; and
- (b) a vehicle unsafely or unlawfully parked that the driver is authorised to remove under any other Act.

### 36 Exemptions for postal vehicles

For the purposes of rule 313 (Exemptions for postal vehicles), the rules mentioned in rule 313(2) do not apply to drivers of postal vehicles engaged in dropping off, or picking up, postal articles.

### 37 Approved bicycle helmets

For the purposes of the Rules and the definition of “**approved bicycle helmet**” in the dictionary at the end of the Rules, helmets are approved bicycle helmets if approved for bicycle riders under the *Road Traffic (Miscellaneous) Regulations 1999*.

### 38 Authorised persons

For the purposes of the Rules and the definition of “**authorised person**” in the dictionary at the end of the Rules, inspectors are authorised persons.

### 39 Emergency workers

For the purposes of the Rules and the definition of “**emergency worker**” in the dictionary at the end of the Rules, the following are emergency workers:

- (a) officers and employees of the South Australian Metropolitan Fire Service and members of a fire brigade registered under the *South Australian Metropolitan Fire Service Act 1936*;
- (b) officers, employees and members of the Country Fire Service under the *Country Fires Act 1989*;
- (c) persons engaged in the provision of ambulance services under the *Ambulance Services Act 1992*;
- (d) persons engaged in the provision of services on behalf of St. John Ambulance Australia, S.A. Incorporated;
- (e) members of State Emergency Service South Australia and emergency officers under the *State Emergency Service Act 1987*;
- (f) authorised officers under the *State Disaster Act 1980*;
- (g) members of the Australian Federal Police or the Australian Customs Service;
- (h) members of the armed forces of the Commonwealth engaged in police, fire fighting or ambulance duties or duties in connection with the urgent disposal of explosives or any emergency.

### 40 Hazard warning lights

For the purposes of the Rules and the definition of “**hazard warning lights**” in the dictionary at the end of the Rules, the lights referred to in the definition are lights of that kind fitted under the *Road Traffic (Vehicle Standards) Rules 1999*.

### 41 Mechanical signalling devices

For the purposes of the Rules and the definition of “**mechanical signalling device**” in the dictionary at the end of the Rules, mechanical signalling devices conforming to the requirements of the *Road Traffic (Vehicle Standards) Rules 1999* are mechanical signalling devices.

**42 Oversize vehicles**

For the purposes of the Rules and the definition of “**oversize vehicle**” in the dictionary at the end of the Rules, vehicles are oversize vehicles if oversize and travelling under a notice or permit within the meaning of the *Road Traffic (Oversize or Overmass Vehicle Exemptions) Regulations 1999*.

**43 Parking permits for people with disabilities**

For the purposes of the Rules and the definition of “**parking permit for people with disabilities**” in the dictionary at the end of the Rules, permits issued under Part 3D of the *Motor Vehicles Act 1959* are parking permits for people with disabilities.

**44 Police officers**

For the purposes of the Rules and the definition of “**police officer**” in the dictionary at the end of the Rules, members of South Australia Police are police officers.

**45 Portable warning triangles**

For the purposes of the Rules and the definition of “**portable warning triangle**” in the dictionary at the end of the Rules, portable warning devices that comply with Australian Standard Specification No. E38-1962 Portable Warning Signs for Motor Vehicles, as amended from time to time, are approved as portable warning triangles.

**46 Postal workers**

For the purposes of the Rules and the definition of “**postal worker**” in the dictionary at the end of the Rules, persons employed by Australia Post are postal workers.

**47 Public buses**

For the purposes of the Rules and the definition of “**public bus**” in the dictionary at the end of the Rules, buses engaged in regular passenger services under the *Passenger Transport Act 1994* are public buses.

**48 Public holidays**

For the purposes of the Rules and the definition of “**public holiday**” in the dictionary at the end of the Rules, a day that is a public holiday under the *Holidays Act 1910* is a public holiday.

**49 Taxis**

For the purposes of the Rules and the definition of “**taxi**” in the dictionary at the end of the Rules, vehicles licensed, or exempted from the requirement to be licensed, under Part 6 of the *Passenger Transport Act 1994* are taxis.

**50 Penalties for offences against Rules**

- (1) A person who is guilty of an offence against a provision of the Rules, other than a provision of Part 12 (Restrictions on stopping and parking), is liable to a penalty not exceeding \$1 250.
- (2) A person who is guilty of an offence against a provision of Part 12 of the Rules is liable to a penalty not exceeding \$500.

## 51 Evidentiary provisions

- (1) In proceedings for offences against the Rules, an allegation in a complaint that—
  - (a) a specified speed-limit applied to a specified length of road; or
  - (b) a specified length of road was, or was not, in a school zone or shared zone; or
  - (c) a specified length of road was, or was not, in a built-up area; or
  - (d) a specified form of crossing was at a specified place; or
  - (e) a specified vehicle lawfully displayed a *do not overtake turning vehicle sign* or a *give way to buses sign*; or
  - (f) a specified fee was not paid for parking a specified vehicle in a specified place; or
  - (g) a specified ticket was not displayed in a specified part of a specified vehicle; or
  - (h) specified information was on or with a specified traffic control device; or
  - (i) a specified traffic control device applied to a specified length of road, portion of road or area; or
  - (j) a specified traffic control device applied to a specified person in a specified place,is proof of the matters so alleged in the absence of proof to the contrary.
- (2) In proceedings for an offence against rule 287 (Duties of driver involved in a crash), an apparently genuine document produced by the prosecution purporting to be signed by the Commissioner of Police and to certify that the required particulars for a specified person had not been given to a police officer before a specified day and time in relation to a specified crash (whether the crash is specified by reference to the approximate time and place of the crash or to the person or persons involved, or otherwise so as to reasonably identify it) is proof of the matters so certified in the absence of proof to the contrary.

## 52 Transitional provisions

- (1) A resolution relating to a permit zone made by a council under the *Local Government (Parking) Regulations 1991* and in force immediately before the commencement of these regulations continues in force as a determination made by the council under regulation 14, subject to variation under that regulation.
- (2) A permit for parking in a permit zone issued by a council and in force immediately before the commencement of these regulations continues in force as a permit issued by the council under regulation 14, subject to the conditions (if any) of the permit.
- (3) A resolution relating to fees for parking payable by the operation of parking ticket-vending machines or parking meters, being a resolution made by a council under the *Local Government (Parking) Regulations 1991* and in force immediately before the commencement of these regulations, continues in force as a determination made by the council under regulation 19, subject to variation under that regulation.

**SCHEDULE 1**

*Areas on which Wheeled Recreational Devices and Toys Prohibited*  
*Regulation 22*

1. (1) The bicycle path adjacent to the Southern Expressway that commences at Darlington Street at Bedford Park and proceeds generally southerly on the eastern side of the carriageway of the Expressway to a point approximately 250 metres north of the intersection of the Expressway, South Road and Panalatinga Road at Trott Park, then generally southerly on the western side of the carriageway of the Expressway to the intersection of Panalatinga Road and Old South Road at Old Reynella.
- (2) In subclause (1)  
“**Southern Expressway**” means Road Number 6780 Southern Expressway between—
  - (a) its intersection with Road Number 6726 Panalatinga Road and Road Number 6203 Main South Road at Trott Park; and
  - (b) its junction with Road Number 6203 Main South Road at Bedford Park.

TSA 11844/98 CS

SUZANNE M. CARMAN, Clerk of the Council

# RULES UNDER THE ROAD TRAFFIC ACT 1961

No. 219 of 1999

*At the Executive Council Office at Adelaide 11 November 1999*

PURSUANT to the *Road Traffic Act 1961* and with the advice and consent of the Executive Council, I make the following rules.

E. J. NEAL Governor

PURSUANT to section 10AA(2) of the *Subordinate Legislation Act 1978*, I certify that, in my opinion, it is necessary or appropriate that the following rules come into operation as set out below.

DIANA LAIDLAW Minister for Transport and Urban Planning

---

## CONTENTS

### Reader's Guide

#### Part 1 Introductory

##### Division 1 General

- 1 Australian Road Rules
- 2 Commencement
- 3 Object of the Australian Road Rules

##### Division 2 Some features of the Australian Road Rules

- 4 Definitions — the dictionary etc
- 5 Diagrams
- 6 Examples
- 7 Headings
- 8 Notes
- 9 Reader's Guide
- 10 Offences

#### Part 2 Application of the Australian Road Rules

##### Division 1 Roads and road-related areas

- 11 Australian Road Rules apply to vehicles and road users on roads and road-related areas
- 12 What is a road
- 13 What is a road-related area

##### Division 2 Road users and vehicles

- 14 Road users
- 15 What is a vehicle
- 16 Who is a driver
- 17 Who is a rider
- 18 Who is a pedestrian

- 19 References to driver includes rider etc

### **Part 3 Speed-limits**

- 20 Obeying the speed-limit
- 21 Speed-limit where a speed-limit sign applies
- 22 Speed-limit in a speed-limited area
- 23 Speed-limit in a school zone
- 24 Speed-limit in a shared zone
- 25 Speed-limit elsewhere

### **Part 4 Making turns**

#### **Division 1 Left turns at intersections**

- 26 Division does not apply to certain turns
- 27 Starting a left turn from a road (except a multi-lane road)
- 28 Starting a left turn from a multi-lane road
- 29 Making a left turn as indicated by a road marking

#### **Division 2 Right turns (except hook turns) at intersections**

- 30 Division does not apply to certain turns
- 31 Starting a right turn from a road (except a multi-lane road)
- 32 Starting a right turn from a multi-lane road
- 33 Making a right turn

#### **Division 3 Hook turns at intersections**

- 34 Making a hook turn at a hook turn only sign
- 35 Optional hook turn by a bicycle rider
- 36 Bicycle rider making a hook turn contrary to no hook turn by bicycles sign

#### **Division 4 U-turns**

- 37 Beginning a U-turn
- 38 Giving way when making a U-turn
- 39 Making a U-turn contrary to a no U-turn sign
- 40 Making a U-turn at an intersection with traffic lights
- 41 Making a U-turn at an intersection without traffic lights
- 42 Starting a U-turn at an intersection

#### **Division 5 Turns into or from road-related areas or adjacent land**

- 43 Starting and making turns

### **Part 5 Change of direction and stop signals**

#### **Division 1 Change of direction signals**

- 44 Division does not apply to entering or leaving a roundabout
- 45 What is changing direction
- 46 Giving a left change of direction signal
- 47 How to give a left change of direction signal
- 48 Giving a right change of direction signal
- 49 How to give a right change of direction signal
- 50 How to give a right change of direction signal by giving a hand signal
- 51 When use of direction indicator lights permitted



**Division 2 Stop signals**

- 52 Division does not apply to bicycle riders or certain tram drivers
- 53 Giving a stop signal
- 54 How to give a stop signal
- 55 How to give a stop signal by giving a hand signal

**Part 6 Traffic lights and twin red lights****Division 1 Obeying traffic lights**

- 56 Stopping for a red traffic light or arrow
- 57 Stopping for a yellow traffic light or arrow
- 58 Exceptions to stopping for a red or yellow traffic light
- 59 Proceeding through a red traffic light
- 60 Proceeding through a red traffic arrow
- 61 Proceeding when traffic lights or arrows at an intersection change to yellow or red

**Division 2 Giving way at traffic lights**

- 62 Giving way when turning at an intersection with traffic lights
- 63 Giving way at an intersection with traffic lights not operating or only partly operating
- 64 Giving way at a flashing yellow traffic arrow at an intersection
- 65 Giving way at a marked foot crossing (except at an intersection) with a flashing yellow traffic light

**Division 3 Twin red lights (except at level crossings)**

- 66 Stopping for twin red lights (except at level crossings)

**Part 7 Giving way****Division 1 Giving way at a stop sign, stop line, give way sign or give way line applying to the driver**

- 67 Stopping and giving way at a stop sign or stop line at an intersection without traffic lights
- 68 Stopping and giving way at a stop sign or stop line at other places
- 69 Giving way at a give way sign or give way line at an intersection
- 70 Giving way at a give way sign at a bridge or length of narrow road
- 71 Giving way at a give way sign or give way line at other places

**Division 2 Giving way at an intersection without traffic lights or a stop sign, stop line, give way sign or give way line applying to the driver**

- 72 Giving way at an intersection (except a T-intersection or roundabout)
- 73 Giving way at a T-intersection

**Division 3 Entering or leaving road-related areas and adjacent land**

- 74 Giving way when entering a road from a road-related area or adjacent land
- 75 Giving way when entering a road-related area or adjacent land from a road

**Division 4 Keeping clear of and giving way to particular vehicles**

- 76 Keeping clear of trams travelling in tram lanes etc
- 77 Giving way to buses
- 78 Keeping clear of police and emergency vehicles
- 79 Giving way to police and emergency vehicles

**Division 5 Crossings and shared zones**

- 80 Stopping at a children's crossing
- 81 Giving way at a pedestrian crossing

- 82 Overtaking or passing a vehicle at a children's crossing or pedestrian crossing
- 83 Giving way to pedestrians in a shared zone

**Division 6 Other give way rules**

- 84 Giving way when driving through a break in a dividing strip
- 85 Giving way on a painted island
- 86 Giving way in median turning bays
- 87 Giving way when moving from a side or shoulder of the road or a median strip parking area

**Part 8 Traffic signs and road markings**

**Division 1 Traffic signs and road markings at intersections**

- 88 Left turn signs
- 89 Right turn signs
- 90 No turns signs
- 91 No left turn and no right turn signs
- 92 Traffic lane arrows

**Division 2 Traffic signs and road markings generally**

- 93 No overtaking or passing signs
- 94 No overtaking on bridge signs
- 95 Emergency stopping lane only signs
- 96 Keep clear markings
- 97 Road access signs
- 98 One-way signs
- 99 Keep left and keep right signs
- 100 No entry signs
- 101 Hand-held stop signs

**Division 3 Signs for trucks, buses and other large vehicles**

- 102 Clearance and low clearance signs
- 103 Load limit signs
- 104 No trucks signs
- 105 Trucks must enter signs
- 106 No buses signs
- 107 Buses must enter signs
- 108 Trucks and buses low gear signs

**Part 9 Roundabouts**

- 109 What is a roundabout
- 110 Meaning of halfway around a roundabout
- 111 Entering a roundabout from a multi-lane road or a road with 2 or more lines of traffic travelling in the same direction
- 112 Giving a left change of direction signal when entering a roundabout
- 113 Giving a right change of direction signal when entering a roundabout
- 114 Giving way when entering or driving in a roundabout
- 115 Driving in a roundabout to the left of the central traffic island
- 116 Obeying traffic lane arrows when driving in or leaving a roundabout
- 117 Giving a change of direction signal when changing marked lanes or lines of traffic in a roundabout
- 118 Giving a left change of direction signal when leaving a roundabout
- 119 Giving way by the rider of a bicycle or animal to a vehicle leaving a roundabout

---

**Part 10 Level crossings**

- 120 What is a level crossing
- 121 Stopping and giving way at a stop sign at a level crossing
- 122 Giving way at a give way sign or give way line at a level crossing
- 123 Entering a level crossing when a train or tram is approaching etc
- 124 Leaving a level crossing

**Part 11 Keeping left, overtaking and other driving rules****Division 1 General**

- 125 Unreasonably obstructing drivers or pedestrians
- 126 Keeping a safe distance behind vehicles
- 127 Keeping a minimum distance between long vehicles
- 128 Entering blocked intersections

**Division 2 Keeping to the left**

- 129 Keeping to the far left side of a road
- 130 Keeping to the left on a multi-lane road
- 131 Keeping to the left of oncoming vehicles
- 132 Keeping to the left of the centre of a road or the dividing line
- 133 Exceptions to keeping to the left of the centre of a road
- 134 Exceptions to keeping to the left of a dividing line
- 135 Keeping to the left of a median strip
- 136 Driving on a one-way service road
- 137 Keeping off a dividing strip
- 138 Keeping off a painted island
- 139 Exceptions for avoiding obstructions on a road

**Division 3 Overtaking**

- 140 No overtaking unless safe to do so
- 141 No overtaking etc to the left of a vehicle
- 142 No overtaking to the right of a vehicle turning right etc
- 143 Passing or overtaking a vehicle displaying a do not overtake turning vehicle sign
- 144 Keeping a safe distance when overtaking
- 145 Driver being overtaken not to increase speed

**Division 4 Driving in marked lanes or lines of traffic**

- 146 Driving within a single marked lane or line of traffic
- 147 Moving from one marked lane to another marked lane across a continuous line separating the lanes
- 148 Giving way when moving from one marked lane or line of traffic to another marked lane or line of traffic
- 149 Giving way when lines of traffic merge into a single line of traffic
- 150 Driving on or across a continuous white edge line
- 151 Riding a motor bike or bicycle alongside more than 1 other rider

**Division 5 Obeying overhead lane control devices applying to marked lanes**

- 152 Complying with overhead lane control devices

**Division 6 Driving in marked lanes designated for special purposes**

- 153 Bicycle lanes
- 154 Bus lanes

- 155 Tram lanes
- 156 Transit lanes
- 157 Truck lanes
- 158 Exceptions to driving in special purpose lanes etc
- 159 Marked lanes required to be used by particular kinds of vehicles

**Division 7 Passing trams and safety zones**

- 160 Passing or overtaking a tram that is not at or near the left side of a road
- 161 Passing or overtaking a tram at or near the left side of a road
- 162 Driving past a safety zone
- 163 Driving past the rear of a stopped tram
- 164 Giving way to pedestrians crossing the road near a stopped tram

**Part 12 Restrictions on stopping and parking**

**Division 1 General**

- 165 Stopping in an emergency etc or to comply with another rule
- 166 Application of Part to bicycles

**Division 2 No stopping and no parking signs and road markings**

- 167 No stopping signs
- 168 No parking signs
- 169 No stopping on a road with a yellow edge line

**Division 3 Stopping at intersections and crossings**

- 170 Stopping in or near an intersection
- 171 Stopping on or near a children's crossing
- 172 Stopping on or near a pedestrian crossing (except at an intersection)
- 173 Stopping on or near a marked foot crossing (except at an intersection)
- 174 Stopping at or near bicycle crossing lights (except at an intersection)
- 175 Stopping on or near a level crossing

**Division 4 Stopping on clearways and freeways and in emergency stopping lanes**

- 176 Stopping on a clearway
- 177 Stopping on a freeway
- 178 Stopping in an emergency stopping lane

**Division 5 Stopping in zones for particular vehicles**

- 179 Stopping in a loading zone
- 180 Stopping in a truck zone
- 181 Stopping in a works zone
- 182 Stopping in a taxi zone
- 183 Stopping in a bus zone
- 184 Stopping in a minibus zone
- 185 Stopping in a permit zone
- 186 Stopping in a mail zone

**Division 6 Other places where stopping is restricted**

- 187 Stopping in a bicycle lane, bus lane, tram lane, transit lane, truck lane or on tram tracks
- 188 Stopping in a shared zone
- 189 Double parking
- 190 Stopping in or near a safety zone
- 191 Stopping near an obstruction

- 
- 192 Stopping on a bridge or in a tunnel etc
  - 193 Stopping on a crest or curve outside a built-up area
  - 194 Stopping near a fire hydrant etc
  - 195 Stopping at or near a bus stop
  - 196 Stopping at or near a tram stop
  - 197 Stopping on a path, dividing strip or nature strip
  - 198 Obstructing access to and from a footpath, driveway etc
  - 199 Stopping near a postbox
  - 200 Stopping on roads — heavy and long vehicles
  - 201 Stopping on a road with bicycle parking sign
  - 202 Stopping on a road with motor bike parking sign
  - 203 Stopping in a parking area for people with disabilities

**Division 7 Permissive parking signs and parking fees**

- 204 Meaning of certain information on or with permissive parking signs
- 205 Parking for longer than indicated
- 206 Time extension for people with disabilities
- 207 Parking where fees are payable

**Division 8 Parallel parking**

- 208 Parallel parking on a road (except in a median strip parking area)
- 209 Parallel parking in a median strip parking area

**Division 9 Angle parking**

- 210 Angle parking

**Division 10 Other parking related rules**

- 211 Parking in parking bays
- 212 Entering and leaving a median strip parking area
- 213 Making a motor vehicle secure

**Part 13 Lights and warning devices**

**Division 1 Lights on vehicles (except bicycles, animals and animal-drawn vehicles)**

- 214 Division does not apply to riders of bicycles, animals or animal-drawn vehicles
- 215 Using lights when driving at night or in hazardous weather conditions
- 216 Towing a vehicle at night or in hazardous weather conditions
- 217 Using rear fog lights
- 218 Using headlights on high-beam
- 219 Lights not to be used to dazzle other road users
- 220 Using lights on vehicles that are stopped
- 221 Using hazard warning lights
- 222 Using warning lights on buses carrying children

**Division 2 Lights on animal-drawn vehicles**

- 223 Using lights when riding an animal-drawn vehicle at night or in hazardous weather conditions

**Division 3 Horns and radar detectors**

- 224 Using horns and similar warning devices
- 225 Using radar detectors and similar devices

**Division 4 Portable warning triangles for heavy vehicles**

- 226 Heavy vehicles to be equipped with portable warning triangles

## **Part 14 Rules for pedestrians**

### **Division 1 General**

- 227 Using portable warning triangles
- 228 No pedestrians signs
- 229 Pedestrians on a road with a road access sign
- 230 Crossing a road — general
- 231 Crossing a road at pedestrian lights
- 232 Crossing a road at traffic lights
- 233 Crossing a road to or from a tram
- 234 Crossing a road on or near a crossing for pedestrians
- 235 Crossing a level crossing
- 236 Pedestrians not to cause a traffic hazard or obstruction
- 237 Getting on or into a moving vehicle
- 238 Pedestrians travelling along a road (except in or on a wheeled recreational device or toy)
- 239 Pedestrians on a bicycle path or separated footpath

### **Division 2 Rules for persons travelling in or on wheeled recreational devices and wheeled toys**

- 240 Wheeled recreational devices and toys not to be used on certain roads
- 241 Travelling in or on a wheeled recreational device or toy on a road
- 242 Travelling in or on a wheeled recreational device or toy on a footpath or shared path
- 243 Travelling on rollerblades etc on a bicycle path or separated footpath
- 244 Holding onto a moving vehicle

## **Part 15 Additional rules for bicycle riders**

- 245 Riding a bicycle
- 246 Carrying people on a bicycle
- 247 Riding in a bicycle lane on a road
- 248 No riding across a road on a crossing
- 249 Riding on a separated footpath
- 250 Riding on a footpath or shared path
- 251 Riding to the left of oncoming bicycle riders on a path
- 252 No bicycles signs and markings
- 253 Bicycle riders not to cause a traffic hazard
- 254 Bicycles being towed etc
- 255 Riding too close to the rear of a motor vehicle
- 256 Bicycle helmets
- 257 Riding with a person on a bicycle trailer
- 258 Equipment on a bicycle
- 259 Riding at night
- 260 Stopping for a red bicycle crossing light
- 261 Stopping for a yellow bicycle crossing light
- 262 Proceeding when bicycle crossing lights change to yellow or red

## **Part 16 Rules for persons travelling in or on vehicles**

- 263 Application of Part to persons in or on trams
- 264 Wearing of seatbelts by drivers
- 265 Wearing of seatbelts by passengers 16 years old, or older
- 266 Wearing of seatbelts by passengers under 16 years old
- 267 Exemptions from wearing seatbelts
- 268 How persons must travel in or on a motor vehicle

- 
- 269 Opening doors and getting out of a vehicle etc
  - 270 Wearing motor bike helmets
  - 271 Riding on motor bikes
  - 272 Interfering with the driver's control of the vehicle etc

## **Part 17 Additional rules for drivers of trams and public buses**

### **Division 1 Trams**

- 273 Division also applies to public buses travelling along tram tracks
- 274 Stopping for a red T light
- 275 Stopping for a yellow T light
- 276 Exception to stopping for a red or yellow T light
- 277 Proceeding after stopping for a red or yellow T light
- 278 Proceeding when a red traffic light and a white T light or white traffic arrow is showing
- 279 Proceeding when a white T light or white traffic arrow is no longer showing

### **Division 2 Public buses**

- 280 Division does not apply to public buses travelling along tram tracks
- 281 Stopping for a red B light
- 282 Stopping for a yellow B light
- 283 Exception to stopping for a red or yellow B light
- 284 Proceeding after stopping for a red or yellow B light
- 285 Proceeding when a red traffic light and a white B light or white traffic arrow is showing
- 286 Proceeding when a white B light or white traffic arrow is no longer showing

## **Part 18 Miscellaneous road rules**

### **Division 1 Miscellaneous rules for drivers**

- 287 Duties of a driver involved in a crash
- 288 Driving on a path
- 289 Driving on a nature strip
- 290 Driving on a traffic island
- 291 Making unnecessary noise or smoke
- 292 Insecure or overhanging load
- 293 Removing fallen etc things from the road
- 294 Keeping control of a vehicle being towed
- 295 Motor vehicle towing another vehicle with a towline
- 296 Driving a vehicle in reverse
- 297 Driver to have proper control of a vehicle etc
- 298 Driving with a person in a trailer
- 299 Television receivers and visual display units in motor vehicles
- 300 Use of hand held-mobile phones

### **Division 2 Rules for people in charge of animals**

- 301 Leading an animal while driving a vehicle
- 302 Rider of an animal on a footpath or nature strip to give way to pedestrians
- 303 Riding an animal alongside more than 1 other rider

### **Division 3 Obeying directions**

- 304 Direction by a police officer or authorised person

---

**Part 19 Exemptions**

- 305 Exemption for drivers of police vehicles
- 306 Exemption for drivers of emergency vehicles
- 307 Stopping and parking exemption for police and emergency vehicles and authorised persons
- 308 Exemption for police officers and emergency workers on foot
- 309 Exemption for drivers of trams etc
- 310 Exemption for road workers etc
- 311 Exemption for oversize vehicles
- 312 Exemption for tow truck drivers
- 313 Exemption for postal vehicles

**Part 20 Traffic control devices and traffic-related items**

**Division 1 General**

- 314 Diagrams of traffic control devices, traffic-related items and symbols
- 315 Legal effect of traffic control devices mentioned in the Australian Road Rules
- 316 When do traffic control devices comply substantially with the Australian Road Rules
- 317 Information on or with traffic control devices
- 318 Limited effect of certain traffic control devices
- 319 Legal effect of traffic-related items mentioned in the Australian Road Rules
- 320 When do traffic-related items comply substantially with the Australian Road Rules
- 321 Meaning of information on or with traffic control devices and traffic-related items
- 322 References to traffic control devices and traffic-related items on a road etc
- 323 References to lights that are traffic signals

**Division 2 Application of traffic control devices to lengths of roads and areas**

- 324 Purpose of Division
- 325 References to traffic control devices — application to lengths of road and areas
- 326 When do traffic control devices apply to a length of road or area — the basic rules
- 327 Length of road to which a traffic sign (except a parking control sign) applies
- 328 References to a traffic control device applying to a length of road
- 329 Traffic control devices applying to a marked lane
- 330 Traffic control devices applying to a slip lane
- 331 Traffic control devices applying to an intersection
- 332 Parking control signs applying to a length of road
- 333 Parking control signs applying to a length of road in an area to which another parking control sign applies etc
- 334 How parking control signs apply to a length of road
- 335 Traffic control devices applying to an area
- 336 How separated footpath signs and separated footpath road markings apply

**Division 3 Application of traffic control devices to persons**

- 337 Purpose of Division
- 338 References to traffic control devices — application to persons
- 339 When do traffic control devices apply to a person — the basic rules
- 340 Traffic control devices (except road markings and parking control signs)
- 341 Road markings
- 342 Traffic signs (except parking control signs) applying to a length of road
- 343 Traffic signs (except parking control signs) applying to an area
- 344 Traffic control devices applying to a driver in a marked lane
- 345 Traffic control devices applying to a driver in a slip lane



---

346 Parking control signs

**Part 21 General**

347 Meaning of abbreviations and symbols

348 References to a driver doing something etc

349 References to certain kinds of roads

350 References to stopping or parking on a length of road etc

351 References to left and right

**Schedule 1**

**Abbreviations and symbols**

**Schedule 2**

**Standard or commonly used traffic signs**

**Schedule 3**

**Other permitted traffic signs**

**Schedule 4**

**Symbols and traffic-related items**

**Dictionary**

***THIS PAGE INTENTIONALLY LEFT BLANK***

---

## Reader's Guide

### **Aim of the Guide**

The aim of this Guide is to help you to understand the Australian Road Rules ('the Rules') and the way they apply to different kinds of roads, vehicles and road users. The Guide also gives information on the structure of the Rules.

As a matter of law, the Guide is not part of the Australian Road Rules.

### **The Australian Road Rules**

The Australian Road Rules provide rules to be followed by all road users.

They are part of a national scheme to provide uniform road laws throughout Australia.

## How to use the Rules

### **1 Contents and dictionary**

The contents at the beginning of the Rules will help you to find particular rules or groups of rules that you may be interested in. They may also be helpful in giving you an overview of the structure of the Rules.

The dictionary at the end of the Rules defines words and expressions that have special meanings in the Rules. It includes words and expressions that are defined elsewhere in the Rules.

### **2 Application of the Rules and some key concepts**

The application of the Australian Road Rules and some key concepts are explained in Part 2 of the Rules. You will need to understand Part 2 to apply the rules properly.

#### *Roads and road-related areas*

The Rules apply to vehicles, animals and persons on roads and 'road-related areas'. 'Road-related areas' are areas like footpaths, nature strips and parking areas. The Rules generally apply to road-related areas in the same way as they apply to roads.

In the Rules, a reference to a 'road' generally includes road-related areas. If a particular rule does not apply to road-related areas, or applies only to road-related areas, this will be stated in the rule.

#### *Drivers and riders*

The Rules are generally expressed to apply to drivers of vehicles, since they are the largest category of road users. A driver is the person driving or otherwise in control of a vehicle. For example, a person steering and pushing a stalled motor vehicle would be in control of the vehicle and be the 'driver'.

Persons riding, or otherwise in control of, motor bikes or animal-drawn vehicles, or riding bicycles or animals, are called 'riders', rather than drivers. The Rules generally apply to them in the same way as they apply to drivers.

In the Rules, a reference to a 'driver' generally includes a rider. If a particular rule does not apply to riders, or applies only to particular kinds of riders, this is stated in the rule.

The definition of a 'vehicle' (also in Part 2) is very broad and is not exhaustive. It includes, for example, motorised wheelchairs that can travel over 10 kilometres per hour. However, it does not include trains, wheeled recreational devices or wheeled toys. The driving of trains is not covered by the Australian Road Rules. Riders of wheeled recreational devices and wheeled toys are treated as pedestrians.

Although most of the rules apply to vehicles of all kinds and to both drivers and riders, there are some rules that apply only to particular drivers or riders. For example, the rules in Part 15 apply only to bicycle riders, and the rules in Part 17 apply only to the drivers of trams and public buses.

### *Pedestrians*

It is not appropriate to apply the Australian Road Rules to persons in control of some kinds of vehicles as if they were drivers of conventional motor vehicles. For this reason, some persons who might otherwise come within the definition of 'driver' are treated as pedestrians. For example, a person pushing a motorised wheelchair is treated as a pedestrian.

The rules that apply to pedestrians are in Part 14.

## **3 Diagrams of traffic signs**

Diagrams of all traffic signs mentioned in the Rules are shown in alphabetical order in Schedules 2 and 3 at the end of the Rules. The traffic signs in Schedule 2 are those in the relevant Australian Standard (AS 1742) as well as some existing non-standard signs in common use that will continue to be used and some new signs. The traffic signs in Schedule 3 are alternative signs still in use in one or more jurisdictions, but are being phased out.

Diagrams of signs have also been included after particular rules to help you identify the signs when reading the Rules. These diagrams may be a black and white version of the signs or may be printed in colour.

A number of traffic signs have 2 or more permitted versions. Notes to the diagrams of signs included in particular rules will tell you if there are other permitted versions of the signs or if the signs can have other permitted features. For example, there is more than one permitted version of a *speed-limit sign*. Also, a *speed-limit sign* can have a different number. Notes to the diagram of the sign in Part 3 will tell you about these things.

Diagrams (including diagrams that are examples) are part of the Rules.

## **4 Notes and examples**

Notes are used throughout the Rules. They may tell you that certain terms are defined (and where they are defined), draw your attention to other relevant rules, or help in other ways. The notes are not part of the Rules.

Examples are also given throughout the Rules, sometimes by explanation and sometimes by diagrams. They are not exhaustive. Examples are part of the Rules.

## **5 Structure and language**

The following points may assist you in reading and understanding the Australian Road Rules.

### *Arrangement of rules*

Rules have been grouped in Parts and Divisions so that rules on the same subject are, as far as possible, together. However, some kinds of rules are relevant in many different situations. For example, in addition to the general give way rules in Part 7, giving way at traffic lights is dealt with in Part 6 (which deals with traffic lights) and giving way at roundabouts is dealt with in Part 9 (which deals with roundabouts). This arrangement gives drivers a more complete picture of their obligations at traffic lights and roundabouts.

Notes at the beginning of a Part, or with an application provision, will tell you where other rules on the subject can be found.

### *Structure of rules*

The rules often deal with complex situations. For this reason the more complex rules set out, in order:

- \_ the rule (that is what must, or must not, be done in the situation covered by the rule)
- \_ the exceptions to the rule
- \_ any other information needed for the application of the rule (for example, particular definitions).

This enables the reader to see the rule set out in the simplest and clearest way.

### *Exemptions*

In addition to exceptions that may be set out in a rule, there are a number of general exemptions. Trams, for example, are exempted from the operation of a number of Parts in the Rules because they run on fixed tracks. The list of exceptions for trams is in Part 19 (Exemptions). Also, in Part 19 there are, for example, a number of general exemptions for police and emergency vehicles and for other vehicles and drivers in particular situations.

A number of rules provide for an exemption if the driver is 'permitted' to do something, or is 'authorised' or 'exempt', 'under another law of this jurisdiction'. Procedures for granting authorisations, permits and exemptions from the Australian Road Rules may vary from jurisdiction to jurisdiction, so the Rules leave these matters to complementary laws of each State or Territory.

### *Definitions included in a rule*

Most definitions of words and expressions are given in the dictionary. However, some terms are defined in the text of a rule. This is done where the word or expression is used only in that rule and nowhere else in the Rules. In addition, some definitions, particularly of areas or lengths of road that are established by traffic signs or road markings, are complex or need diagrams to be fully understood. They are placed with the basic rule that deals with the area or length of road, so that the rule and the definition (with any accompanying diagrams) can be seen and understood together. For example, see the definitions of *bicycle path* and *separated footpath* in rule 239. This also means there is no need for diagrams of the signs to appear in the dictionary as well as at the end of the rule and in the Schedules. The definitions are, however, signposted in the dictionary at the end of the Rules. Notes are also included in relevant rules drawing attention to these definitions.

### *Use of the terms **vehicle** and **road** in a rule*

Because of the way 'driver' is defined, it is generally not necessary to say 'the driver of a vehicle' or mention the driver's vehicle in a rule.

In the same way, because the Australian Road Rules apply only to roads and road-related areas, it is not generally necessary to say in a rule that something must, or must not, be done, 'on a road', except where the kind of road, or the place on a road, is relevant to the rule or it is necessary to exclude road-related areas.

### *Use of the terms **bus** and **public bus***

If a rule is directed to the driver of a public bus, the term 'public bus' is used in the rule, and the rule applies only to public buses. For examples, see Part 17 (Additional rules for drivers of trams and public buses). However, if a rule directs a driver of any vehicle to take or not take some action in relation to a bus, the term 'bus' is used and the rule applies to buses of all kinds. This is because, although the rule is primarily intended to apply to public buses, a public bus may not be marked in a way that makes it distinguishable from a private bus, and it is preferable from the point of view of road safety that the driver treat any bus as a

public bus. For examples see Part 11, Division 7 (Passing trams and safety zones). There are also some rules that refer specifically to the drivers of all buses.

#### *Use of the term **does not apply** in relation to a rule*

A rule may say that it does not apply to a driver of a particular kind, or in a particular situation. This does not mean, however, that another rule will not apply to the driver in the same situation. An example is rule 95 (Emergency stopping lane only signs). A bicycle rider does not commit an offence under rule 95 by riding in an emergency stopping lane, because the rule expressly states that it does not apply to bicycle riders. However, the rider may still commit an offence by riding in the emergency stopping lane if a *no bicycles sign* applies to the lane (see rule 252 (No bicycles signs and markings)).

#### *Use of present tense for some actions*

The rules may say that a driver 'is turning' at an intersection. The use of the present tense is intended to cover both the present and future aspects of the present tense. That is, it refers to a driver who is preparing to make the turn as well as a driver who is in the course of making the turn. The context will make this clear in the rule.

#### *Obligation to **give way***

There are a number of rules requiring a driver to give way to another driver or a pedestrian. However, under the Rules the other driver or pedestrian does not have a 'right' of way. Indeed, in some situations, a number of drivers may be required to give way to each other, eg at an intersection with a *stop sign* or *give way sign* on more than 1 of the intersecting roads. Similarly, although a driver may be required to give way to a pedestrian, the pedestrian is required under rule 236 (1) not to cause a traffic hazard by moving into the driver's path.

## **Offences and penalties**

If a rule (or subrule) creates an offence, this is indicated by the words 'Offence provision.' set out in the rule (or subrule). A person who breaches the rule (or subrule) commits an offence.

The penalty for an offence is set by other laws of each jurisdiction. Penalties can include a fine and, in some circumstances, disqualification from driving.

## **Other aids to using and understanding the Rules**

Part 20 of the Rules explains how traffic signs, traffic signals, road markings and other traffic control devices on roads must comply with the Rules to be legally effective. The Part also explains the way traffic control devices apply to lengths of road and areas, and also to drivers and other road users. Traffic signs and signals generally apply to a person if they face the person, but there are exceptions.

Part 21 of the Rules contains a number of provisions to put certain legal issues beyond doubt. They enable the language and concepts in the Australian Road Rules to be expressed more simply.

## **Other road laws**

The Australian Road Rules are not completely self-contained and need to be read with the associated laws of each jurisdiction. These laws deal with administrative and legal issues that may be particular to each jurisdiction. For example, each jurisdiction defines 'emergency worker' and 'police officer' in slightly different ways for the Australian Road Rules. The definitions of these terms in the dictionary indicate that the terms are defined under other laws of the jurisdiction.

---

The Australian Road Rules do not provide all the rules to be followed by road users. Other rules applying to road users are to be found in other laws. For example, other laws deal with drink-driving. Some of these other rules are indicated by notes in the Rules.

***THIS PAGE INTENTIONALLY LEFT BLANK***



## **Part 1      Introductory**

### **Division 1      General**

#### **1      Citation**

These rules may be cited as the *Australian Road Rules*.

#### **2      Commencement**

The *Australian Road Rules* will come into operation on 1 December 1999.

#### **3      Object of the Australian Road Rules**

The object of the *Australian Road Rules* is to provide road rules in this jurisdiction that are uniform with road rules elsewhere in Australia.

## **Division 2        Some features of the Australian Road Rules**

### **4        Definitions — the dictionary etc**

- (1) The dictionary at the end of the *Australian Road Rules* defines certain words and expressions, and includes references to certain words and expressions defined elsewhere in the Rules (*signpost definitions*).

*Example*

The signpost definition '*road-related area* see rule 13' means that the expression *road-related area* is defined in rule 13 of the *Australian Road Rules*.

*Note* The dictionary only includes a signpost definition for a word or expression if the word or expression is used in 2 or more rules of the *Australian Road Rules*.

- (2) The dictionary is part of the *Australian Road Rules*.
- (3) A definition in the *Australian Road Rules* applies to each use of the word or expression in the Rules, unless the contrary intention appears.

### **5        Diagrams**

A diagram in the *Australian Road Rules* is part of the Rules.

*Note 1* If a diagram of a traffic control device, traffic-related item or symbol is in black and white in a rule of the *Australian Road Rules*, the diagram may be a black and white version of the device, item or symbol — see rule 314. If so, the colour version of the device, item or symbol will be in Schedule 2 or 4.

*Note 2* A diagram may be an example — see rule 6 (1).

### **6        Examples**

- (1) An example (whether or not in the form of a diagram) in the *Australian Road Rules* is part of the Rules.
- (2) If the *Australian Road Rules* includes an example of the operation of a provision of the Rules:
  - (a) the example is not exhaustive; and
  - (b) the example does not limit, but may extend, the meaning of the provision.

### **7        Headings**

A heading to a Part, Division, Schedule, rule or any other provision of the *Australian Road Rules* is part of the Rules.

### **8        Notes**

A note in the *Australian Road Rules* is explanatory and is not part of the Rules.

### **9        Reader's Guide**

The Reader's Guide is not part of the *Australian Road Rules*.

## 10 Offences

- (1) The words 'Offence provision.' in a rule of the *Australian Road Rules* (or, if the rule has 2 or more subrules, in a subrule) indicates that a contravention of the rule (or subrule) is an offence.
- (2) The penalty for an offence is the penalty applying to the offence under another law of this jurisdiction.

***THIS PAGE INTENTIONALLY LEFT BLANK***

## Part 2 Application of the Australian Road Rules

### Division 1 Roads and road-related areas

#### 11 Australian Road Rules apply to vehicles and road users on roads and road-related areas

- (1) The *Australian Road Rules* apply to vehicles and road users on roads and road-related areas.

*Note* **Road** is defined in rule 12, **road-related area** is defined in rule 13, **road user** is defined in rule 14, and **vehicle** is defined in rule 15.

- (2) Each reference in the *Australian Road Rules* (except in this Division) to a **road** includes a reference to a **road-related area**, unless otherwise expressly stated in the Rules.

*Examples for subrule (2)*

1 A reference in rule 146 (which deals with driving within a single marked lane or line of traffic) to the road includes a reference to the road-related area of the road.

2 A reference in rule 200 (1) (which deals with certain heavy or long vehicles stopping on roads) to a length of road includes a reference to the road-related area of the length of road.

3 A reference in rule 31 (which deals with starting a right turn from a road, except a multi-lane road) to a road does not include a reference to a road-related area, because of the definition in subrule (5) of that rule.

#### 12 What is a road

- (1) A **road** is an area that is open to or used by the public and is developed for, or has as one of its main uses, the driving or riding of motor vehicles.

*Note* **Motor vehicle** is defined in the dictionary.

- (2) However, unless the contrary intention appears, a reference in the *Australian Road Rules* (except in this Division) to a **road** does not include a reference to:

- (a) an area so far as the area is declared, under another law of this jurisdiction, not to be a road for the *Australian Road Rules*; or
- (b) any shoulder of the road.

- (3) The **shoulder** of the road includes any part of the road that is not designed to be used by motor vehicles in travelling along the road, and includes:

- (a) for a kerbed road — any part of the kerb; and
- (b) for a sealed road — any unsealed part of the road, and any sealed part of the road outside an edge line on the road;

but does not include a bicycle path, footpath or shared path.

*Note* **Bicycle path** is defined in rule 239, **edge line** and **footpath** are defined in the dictionary, and **shared path** is defined in rule 242.

### 13 What is a road-related area

(1) A *road-related area* is any of the following:

- (a) an area that divides a road;
- (b) a footpath or nature strip adjacent to a road;
- (c) an area that is not a road and that is open to the public and designated for use by cyclists or animals;
- (d) an area that is not a road and that is open to or used by the public for driving, riding or parking vehicles.

*Note* **Vehicle** is defined in rule 15.

(2) However, unless the contrary intention appears, a reference in the *Australian Road Rules* (except in this Division) to a *road-related area* includes a reference to:

- (a) an area so far as the area is declared, under another law of this jurisdiction, to be a road-related area for the *Australian Road Rules*; or
- (b) any shoulder of a road; or
- (c) any other area that is a footpath or nature strip as defined in the dictionary;

but does not include a reference to an area so far as the area is declared, under another law of this jurisdiction, not to be a road-related area for the *Australian Road Rules*.

*Note* **Shoulder** is defined in rule 12.

## Division 2 Road users and vehicles

### 14 Road users

A **road user** is a driver, rider, passenger or pedestrian.

*Note* **Driver** is defined in rule 16, **pedestrian** is defined in rule 18, and **rider** is defined in rule 17.

### 15 What is a vehicle

A **vehicle** includes:

- (a) a motor vehicle, trailer and tram; and
- (b) a bicycle; and
- (c) an animal-drawn vehicle, and an animal that is being ridden or drawing a vehicle; and
- (d) a combination; and
- (e) a motorised wheelchair that can travel at over 10 kilometres per hour (on level ground); but does not include another kind of wheelchair, a train, or a wheeled recreational device or wheeled toy.

*Note* Various terms mentioned in this rule are defined in the dictionary.

### 16 Who is a driver

- (1) A **driver** is the person who is driving a vehicle (except a motor bike, bicycle, animal or animal-drawn vehicle).

*Note 1* **Bicycle** and **motor bike** are defined in the dictionary, and **vehicle** is defined in rule 15.

*Note 2* **Drive** includes be in control of — see the definition in the dictionary.

- (2) However, a **driver** does not include a person pushing a motorised wheelchair.

*Note* **Wheelchair** is defined in the dictionary.

### 17 Who is a rider

- (1) A **rider** is the person who is riding a motor bike, bicycle, animal or animal-drawn vehicle.

*Note 1* **Bicycle** and **motor bike** are defined in the dictionary.

*Note 2* **Ride**, for the rider of a motor bike or animal-drawn vehicle, includes be in control of — see the definition in the dictionary.

- (2) A **rider** does not include:

- (a) a passenger; or
- (b) a person walking beside and pushing a bicycle.

**18 Who is a pedestrian**

A *pedestrian* includes:

- (a) a person driving a motorised wheelchair that cannot travel at over 10 kilometres per hour (on level ground); and
- (b) a person in a non-motorised wheelchair; and
- (c) a person pushing a motorised or non-motorised wheelchair; and
- (d) a person in or on a wheeled recreational device or wheeled toy.

*Note* *Wheelchair*, *wheeled recreational device* and *wheeled toy* are defined in the dictionary.

**19 References to driver includes rider etc**

Unless otherwise expressly stated in the *Australian Road Rules*, each reference in the Rules (except in this Division) to a *driver* includes a reference to a rider, and each reference in the Rules (except in this Division) to *driving* includes a reference to riding.



## Part 3 Speed-limits

### 20 Obeying the speed-limit

A driver must not drive at a speed over the speed-limit applying to the driver for the length of road where the driver is driving.

Offence provision.

*Note 1* The rules about speed-limits are as follows:

- rule 21 — speed-limit where a *speed-limit sign* applies
- rule 22 — speed-limit in a speed-limited area
- rule 23 — speed-limit in a school zone
- rule 24 — speed-limit in a shared zone
- rule 25 — speed-limit elsewhere.

*Note 2* **Road** includes a road-related area — see rule 11 (2).

*Note 3* **Length** of road includes a marked lane, a part of a marked lane, or another part of a length of road — see the definition in the dictionary.

*Note 4* Part 20, Division 2 deals with the way in which a traffic sign applies to a length of road. Part 20, Division 3 deals with the way in which the traffic sign applies to drivers driving on the length of road.

### 21 Speed-limit where a speed-limit sign applies

- (1) The speed-limit applying to a driver for a length of road to which a *speed-limit sign* applies is the number of kilometres per hour indicated by the number on the sign.

*Note* **Length** of road is defined in the dictionary.

- (2) However, if the number on the *speed-limit sign* is over 100 and the driver is driving a bus with a GVM over 5 tonnes, or another vehicle with a GVM over 12 tonnes, the speed-limit applying to the driver for the length of road is 100 kilometres per hour.

*Note 1* **Bus** and **GVM** are defined in the dictionary, and **vehicle** is defined in rule 15.

*Note 2* Five tonnes is specified for the definition of heavy omnibus in the Australian Design Rules issued under the *Motor Vehicle Standards Act 1989* (Cth).

*Note 3* If the vehicle is an oversize or overmass vehicle, the vehicle may be restricted to a lower speed-limit under another law of this jurisdiction.

- (3) A *speed-limit sign* on a road applies to the length of road beginning at the sign and ending at the nearest of the following:
  - (a) a *speed-limit sign* on the road with a different number on the sign;
  - (b) an *end speed-limit sign* or *speed derestriction sign* on the road;
  - (c) if the road ends at a T-intersection or dead end — the end of the road.

*Note 1* **T-intersection** is defined in the dictionary.

*Note 2* Rule 322 (1) and (2) deal with the meaning of a traffic sign **on** a road.

**Rule 22**

Speed-limit signs

Speed-limit sign  
(Standard sign)

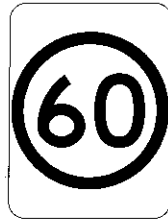

Speed-limit sign  
(Variable illuminated message sign)



Other signs

End speed-limit sign

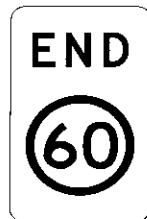

Speed derestriction sign



*Note 1 for diagrams* There is another permitted version of the *speed-limit sign* and the *end speed-limit sign* — see the diagrams in Schedule 3.

*Note 2 for diagrams* A *speed-limit sign* or *end speed-limit sign* may have a different number on the sign — see rule 316 (4).

**22 Speed-limit in a speed-limited area**

- (1) The speed-limit applying to a driver for any length of road in a speed-limited area is the number of kilometres per hour indicated by the number on the *area speed-limit sign* on a road into the area, unless another speed-limit applies to the driver for the length of road under another rule of this Part.

*Example of another speed-limit*

Although an *area speed-limit sign* on a road into a speed-limited area may indicate a speed-limit of 60 kilometres per hour, a particular length of road in the area may have a *school zone sign* indicating a 40 kilometres per hour speed-limit for that length of road.

*Note* **Length** of road is defined in the dictionary.

- (2) A **speed-limited area** is the network of roads in an area with:
  - (a) an *area speed-limit sign* on each road into the area, indicating the same number; and
  - (b) an *end area speed-limit sign* on each road out of the area.

- (3) In subrule (2) (a) and (b):  
**road** does not include a road-related area.

*Note* **Road-related area** is defined in rule 13.

Area speed-limit sign

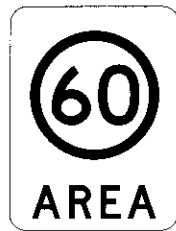

End area speed-limit sign

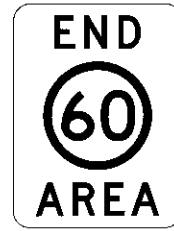

*Note 1 for diagrams* There are a number of other permitted versions of each of these signs — see the diagrams in Schedule 3.

*Note 2 for diagrams* An *area speed-limit sign* or *end area speed-limit sign* may have a different number on the sign — see rule 316 (4).

### 23 Speed-limit in a school zone

- (1) The speed-limit applying to a driver for any length of road in a school zone is the number of kilometres per hour indicated by the number on the *school zone sign* on a road, or the road, into the zone.

*Note 1* **Length** of road is defined in the dictionary.

*Note 2* A *school zone sign* may indicate that it applies only at certain times, on certain days or in certain circumstances — see rules 317 and 318.

*Note 3* This subrule applies to road-related areas in the school zone — see rule 11 (2).

- (2) A *school zone* is:

- (a) if there is a *school zone sign* and an *end school zone sign*, or a *speed-limit sign* with a different number on the sign, on a road and there is no intersection on the length of road between the signs — that length of road; or
- (b) if there is a *school zone sign* on a road that ends in a dead end and there is no intersection, nor a sign mentioned in paragraph (a), on the length of road beginning at the sign and ending at the dead end — that length of road; or
- (c) in any other case — the network of roads in an area with:
  - (i) a *school zone sign* on each road into the area, indicating the same number; and
  - (ii) an *end school zone sign*, or a *speed-limit sign* indicating a different number, on each road out of the area.

*Note* **Intersection** is defined in the dictionary.

- (3) In subrule (2) (c) (i) and (ii):

**road** does not include a road-related area.

*Note* **Road-related area** is defined in rule 13.

**Rule 24**

School zone sign



End school zone sign



*Note 1 for diagrams* There are a number of other permitted versions of each of these signs — see the diagrams in Schedule 3.

*Note 2 for diagrams* A *school zone sign* or *end school zone sign* may have a different number on the sign — see rule 316 (4).

**24 Speed-limit in a shared zone**

- (1) The speed-limit applying to a driver for any length of road in a shared zone is the number of kilometres per hour indicated by the number on the *shared zone sign* on a road into the zone.

*Note* A driver driving in a shared zone must give way to any pedestrian in the zone — see rule 83.

- (2) A *shared zone* is the network of roads in an area with:
  - (a) a *shared zone sign* on each road into the area, indicating the same number; and
  - (b) an *end shared zone sign* on each road out of the area.

- (3) In subrule (2) (a) and (b):  
**road** does not include a road-related area.

*Note* **Road-related area** is defined in rule 13.

Shared zone sign



End shared zone sign



*Note 1 for diagrams* There are a number of other permitted versions of each of these signs — see the diagrams in Schedule 3.

*Note 2 for diagrams* A *shared zone sign* may have a different number on the sign — see rule 316 (4).

**25 Speed-limit elsewhere**

- (1) If a *speed-limit sign* does not apply to a length of road and the length of road is not in a speed-limited area, school zone or shared zone, the speed-limit applying to a driver for the length of road is the default speed-limit.

*Note* **Length** of road is defined in the dictionary, **school zone** is defined in rule 23, **shared zone** is defined in rule 24, and **speed-limited area** is defined in rule 22.

**Rule 25**

---

- (2) The *default speed-limit* applying to a driver for a length of road in a built-up area is 60 kilometres per hour.

*Note* **Built-up area** is defined in the dictionary.

- (3) The *default speed-limit* applying to a driver for any other length of road is:

- (a) for a driver driving a bus with a GVM over 5 tonnes, or another vehicle with a GVM over 12 tonnes — 100 kilometres per hour; or
- (b) for any other driver — 100 kilometres per hour or as otherwise provided under another law of this jurisdiction.

*Note 1* **Bus** and **GVM** are defined in the dictionary, and **vehicle** is defined in rule 15.

*Note 2* Five tonnes is specified for the definition of heavy omnibus in the Australian Design Rules issued under the *Motor Vehicle Standards Act 1989* (Cth).

*Note 3* If the vehicle is an oversize or overmass vehicle, the vehicle may be restricted to a lower speed-limit under another law of this jurisdiction.

***THIS PAGE INTENTIONALLY LEFT BLANK***

## Part 4 Making turns

### Division 1 Left turns at intersections

#### 26 Division does not apply to certain turns

- (1) This Division does not apply to:
  - (a) a driver turning from a road into a road-related area or adjacent land, or from a road-related area into a road; or
  - (b) a driver entering or leaving a roundabout.

- (2) In this rule:

**road** does not include a road-related area.

*Note 1* **Adjacent land** is defined in the dictionary, **road-related area** is defined in rule 13, and **roundabout** is defined in rule 109.

*Note 2* Division 5 of this Part deals with turning into or from a road-related area or adjacent land, and Part 9 deals with entering and leaving a roundabout.

*Note 3* For the meaning of **left**, see rule 351 (1).

#### 27 Starting a left turn from a road (except a multi-lane road)

- (1) A driver turning left at an intersection from a road (except a multi-lane road) must approach and enter the intersection from as near as practicable to the far left side of the road.

Offence provision.

- (2) In this rule:

**road** does not include a road-related area.

*Note 1* **Intersection** and **multi-lane road** are defined in the dictionary.

*Note 2* **Road-related area** includes any shoulder of a road — see rule 13.

*Example*

Starting a left turn from a road (except a multi-lane road)

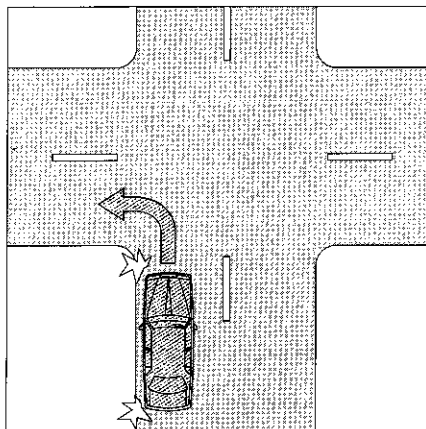

## 28 Starting a left turn from a multi-lane road

- (1) A driver turning left at an intersection from a multi-lane road must approach and enter the intersection from within the left lane unless:
- (a) the driver is required or permitted to approach and enter the intersection from within another marked lane under rule 88 (1), 92 or 159; or
  - (b) the driver is turning, at B lights or traffic arrows, in accordance with Division 2 of Part 17; or
  - (c) subrule (2) applies to the driver.

Offence provision.

*Note 1* **B lights, intersection, marked lane, multi-lane road, public bus** and **traffic arrows** are defined in the dictionary, and **left lane** is defined in subrule (3).

*Note 2* Rule 88 (1) deals with *left turn only signs*, rule 92 deals with traffic lane arrows, and rule 159 deals with traffic signs requiring particular kinds of vehicles to drive in an indicated marked lane.

*Note 3* Division 2 of Part 17 provides for priority to be given to public buses at intersections with B lights or a white traffic arrow.

*Example for subrule (1) (a)*

Starting a left turn on a multi-lane road with traffic lane arrows as required or permitted under rule 92

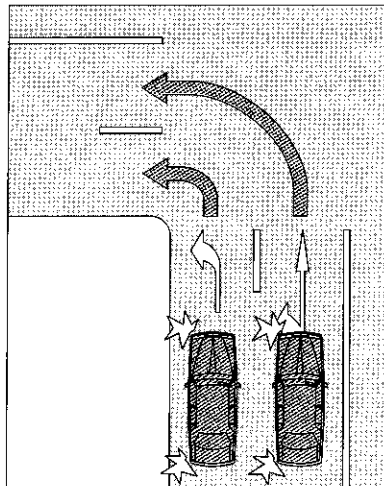

- (2) A driver may approach and enter the intersection from the marked lane next to the left lane as well as, or instead of, the left lane if:
- (a) the driver's vehicle, together with any load or projection, is 7.5 metres long, or longer; and
  - (b) the vehicle displays a *do not overtake turning vehicle sign*; and
  - (c) any part of the vehicle is within 50 metres of the nearest point of the intersection; and
  - (d) it is not practicable for the driver to turn left from within the left lane; and
  - (e) the driver can safely occupy the next marked lane and can safely turn left at the intersection by occupying the next marked lane, or both lanes.

*Note 1* **Driver's vehicle** is defined in the dictionary.

*Note 2* **Vehicle** includes a combination — see rule 15 (d).

*Note 3* Under the law of this jurisdiction, only certain long vehicles may display a *do not overtake turning vehicle sign*.



*Example*

Long vehicle turning left from the left lane and next marked lane

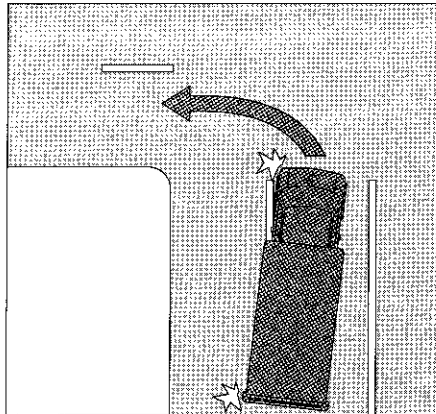

(3) In this rule:

**left lane** means:

- (a) the marked lane nearest to the far left side of the road; or
- (b) if there is an obstruction (for example, a parked car or roadworks) in that marked lane — the marked lane nearest to that marked lane that is not obstructed.

**marked lane**, for a driver, does not include a special purpose lane in which the driver is not permitted to drive.

*Note 1* **Obstruction** and **special purpose lane** are defined in the dictionary.

*Note 2* Rule 95 deals with driving in an emergency stopping lane and Part 11, Division 6 deals with driving in other special purpose lanes.

Do not overtake turning vehicle signs



*Note for diagrams* These signs are displayed on certain long vehicles.

**29 Making a left turn as indicated by a road marking**

If a driver is turning left at an intersection and there is a road marking indicating how the turn is required to be made, the driver must make the turn as indicated by the road marking.

Offence provision.

*Note* **Intersection** and **road marking** are defined in the dictionary.

*Example*

Making a left turn as indicated by road markings

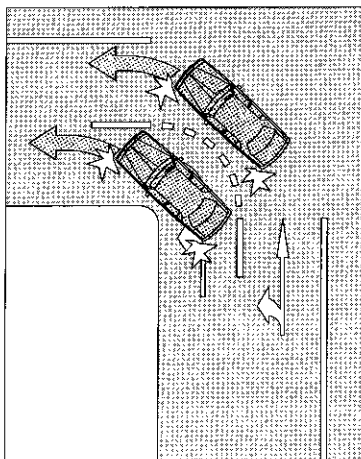

## Division 2 Right turns (except hook turns) at intersections

### 30 Division does not apply to certain turns

- (1) This Division does not apply to:
  - (a) a driver turning right at an intersection where there is a *hook turn only sign*; or
  - (b) the rider of a bicycle making a hook turn under Division 3; or
  - (c) a driver turning from a road into a road-related area or adjacent land, or from a road-related area into a road; or
  - (d) a driver making a U-turn; or
  - (e) a driver entering or leaving a roundabout.

- (2) In subrule (1) (c):

**road** does not include a road-related area.

*Note 1* **Adjacent land**, **bicycle**, **intersection** and **U-turn** are defined in the dictionary, **road-related area** is defined in rule 13, and **roundabout** is defined in rule 109.

*Note 2* Division 3 of this Part deals with hook turns, Division 4 deals with U-turns, Division 5 deals with turns into or from a road-related area or adjacent land, and Part 9 deals with entering and leaving a roundabout.

*Note 3* For the meaning of **right**, see rule 351 (2).

### 31 Starting a right turn from a road (except a multi-lane road)

- (1) A driver turning right at an intersection from a road (except a multi-lane road) must approach and enter the intersection in accordance with this rule.

Offence provision.

*Note* **Intersection** and **multi-lane road** are defined in the dictionary.

- (2) If the road has a dividing line or median strip, the driver must approach and enter the intersection from the left of, parallel to, and as near as practicable to, the dividing line or median strip.

*Note* **Dividing line** and **median strip** are defined in the dictionary.

- (3) If the road does not have a dividing line or median strip and is not a one-way road, the driver must approach and enter the intersection from the left of, parallel to, and as near as practicable to, the centre of the road.

*Note* **Centre of the road** and **one-way road** are defined in the dictionary.

- (4) If the road is a one-way road, the driver must approach and enter the intersection from as near as practicable to the far right side of the road.

- (5) In this rule:

**road** does not include a road-related area.

*Note* **Road-related area** includes any shoulder of a road — see rule 13.

*Examples*

Example 1  
Starting a right turn from a road with a dividing line

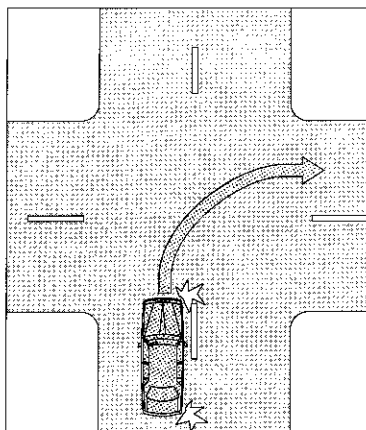

Example 2  
Starting a right turn from a one-way road

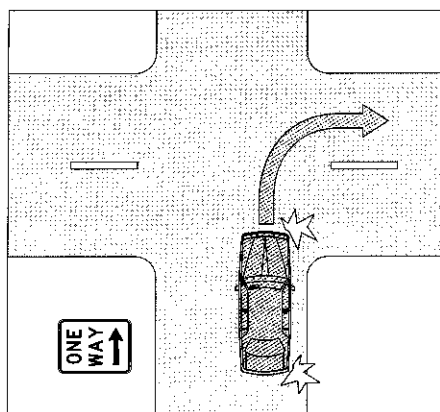

**32 Starting a right turn from a multi-lane road**

- (1) A driver turning right at an intersection from a multi-lane road must approach and enter the intersection from within the right lane unless:
- (a) the driver is required or permitted to approach and enter the intersection from within another marked lane in accordance with rule 89 (1), 92 or 159; or
  - (b) the driver is turning, at B lights or traffic arrows, in accordance with Division 2 of Part 17;  
or
  - (c) subrule (2) applies to the driver.

Offence provision.

*Note 1* **B lights, intersection, marked lane, multi-lane road, public bus** and **traffic arrows** are defined in the dictionary, and **right lane** is defined in subrule (3).

*Note 2* Rule 89 (1) deals with **right turn only signs**, rule 92 deals with traffic lane arrows, and rule 159 deals with traffic signs requiring particular kinds of vehicles to drive in an indicated marked lane.

*Note 3* Division 2 of Part 17 provides for priority to be given to public buses at intersections with B lights or a white traffic arrow.

*Example for subrule (1) (a)*

Starting a right turn on a multi-lane road with traffic lane arrows as required or permitted under rule 92

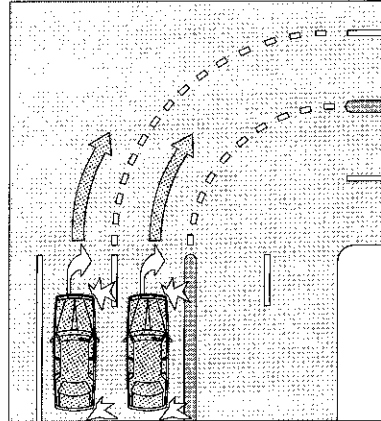

- (2) A driver may approach and enter the intersection from the marked lane next to the right lane as well as, or instead of, the right lane if:
- the driver's vehicle, together with any load or projection, is 7.5 metres long, or longer; and
  - the vehicle displays a *do not overtake turning vehicle sign*; and
  - any part of the vehicle is within 50 metres of the nearest point of the intersection; and
  - it is not practicable for the driver to turn right from within the right lane; and
  - the driver can safely occupy the next marked lane and can safely turn right at the intersection by occupying the next marked lane, or both lanes.

*Note 1* **Driver's vehicle** is defined in the dictionary.

*Note 2* **Vehicle** includes a combination — see rule 15 (d).

*Note 3* Under the law of this jurisdiction, only certain long vehicles may display a *do not overtake turning vehicle sign*.

- (3) In this rule:

**marked lane**, for a driver, does not include a special purpose lane in which the driver is not permitted to drive.

**right lane** means:

- the marked lane nearest to the dividing line or median strip on the road; or
- if there is an obstruction (for example, a parked car or roadworks) in that marked lane — the marked lane nearest to that marked lane that is not obstructed.

*Note 1* **Dividing line, median strip, obstruction** and **special purpose lane** are defined in the dictionary.

*Note 2* Rule 95 deals with driving in an emergency stopping lane and Part 11, Division 6 deals with driving in other special purpose lanes.

Do not overtake turning vehicle signs



*Note for diagrams* These signs are displayed on certain long vehicles.

### 33 Making a right turn

- (1) A driver turning right at an intersection (except a T-intersection) must make the turn in accordance with this rule.

Offence provision.

*Note* **Intersection** and **T-intersection** are defined in the dictionary.

- (2) If there is a road marking indicating how the turn is required to be made, the driver must make the turn as indicated by the road marking.

*Note* **Road marking** is defined in the dictionary.

- (3) If there is no road marking indicating how the turn is required to be made, the driver must make the turn so the driver passes as near as practicable to the right of the centre of the intersection.

*Examples*

#### Example 1

Making a right turn as indicated by road markings

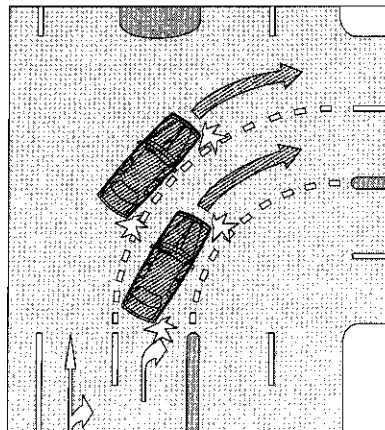

Example 2  
Making a right turn from a road with no road marking  
indicating how to make the turn

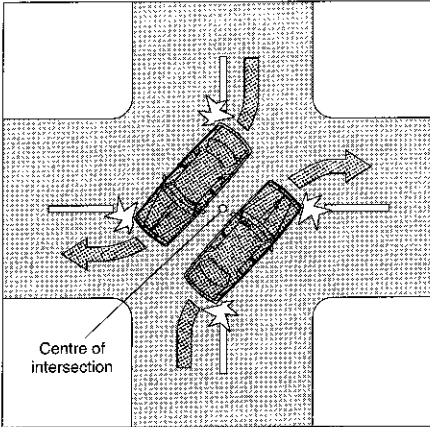

## Division 3 Hook turns at intersections

### 34 Making a hook turn at a hook turn only sign

- (1) A driver turning right at an intersection with traffic lights and a *hook turn only sign* must turn right by making a hook turn in accordance with this rule.

Offence provision.

*Note Intersection and traffic lights* are defined in the dictionary.

- (2) To make a **hook turn**, the driver must take, in sequence, each of the following steps:
- 1 Approach and enter the intersection from as near as practicable to the far left side of the road that the driver is leaving.
  - 2 Move forward, keeping as near as practicable to the left of the intersection and clear of any marked foot crossing, until the driver is as near as practicable to the far side of the road that the driver is entering.
  - 3 Remain at the position reached under step 2 until the traffic lights on the road that the driver is entering change to green.
  - 4 Turn right into that road.

*Note Marked foot crossing* is defined in the dictionary.

- (3) In this rule:

**road** does not include a road-related area.

*Note Road-related area* is defined in rule 13.

Hook turn only sign

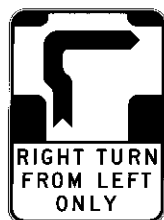

*Example*  
Making a hook turn at a hook turn only sign

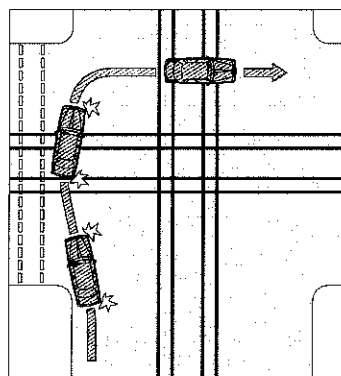

### 35 Optional hook turn by a bicycle rider

- (1) The rider of a bicycle turning right at an intersection without a *hook turn only sign*, or a *no hook turn by bicycles sign*, may turn right at the intersection by making a right turn under Division 2 or a hook turn under this rule.

*Note Bicycle and intersection* are defined in the dictionary.



- (2) The rider must make a hook turn under this rule in accordance with subrule (3).

Offence provision.

- (3) To make a **hook turn** under this rule, the rider must take, in sequence, each of the following steps:

- 1 Approach and enter the intersection from as near as practicable to the far left side of the road that the rider is leaving.
- 2 Move forward:
  - (a) keeping as near as practicable to the far left side of the intersection; and
  - (b) keeping clear of any marked foot crossing; and
  - (c) keeping clear, as far as practicable, of any driver turning left from the left of the intersection;until the rider is as near as practicable to the far side of the road that the rider is entering.
- 3 If there are traffic lights at the intersection, remain at the position reached under step 2 until the traffic lights on the road that the rider is entering change to green.
- 4 If there are no traffic lights at the intersection, remain at the position reached under step 2 until the rider has given way to approaching drivers on the road that the rider is leaving.
- 5 Turn right into the road that the rider is entering.

*Note* **Approaching** and **marked foot crossing** is defined in the dictionary.

*Example*

Bicycle rider making a hook turn at an intersection without traffic lights

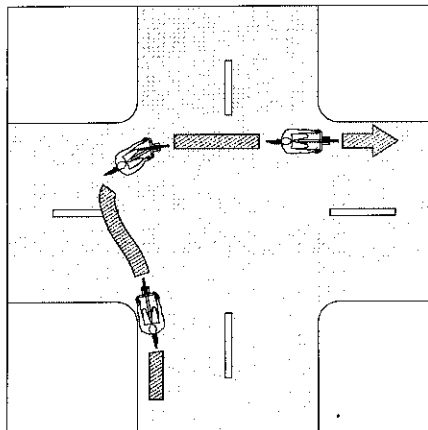

**36 Bicycle rider making a hook turn contrary to no hook turn by bicycles sign**

The rider of a bicycle must not make a hook turn at an intersection that has a *no hook turn by bicycles sign*.

Offence provision.

*Note* **Bicycle** and **intersection** are defined in the dictionary.

No hook turn by bicycles sign



## Division 4 U-turns

*Note* **U-turn** is defined in the dictionary.

### 37 Beginning a U-turn

A driver must not begin a U-turn unless:

- (a) the driver has a clear view of any approaching traffic; and
- (b) the driver can safely make the U-turn without unreasonably obstructing the free movement of traffic.

Offence provision.

*Note 1* **Approaching** traffic means traffic approaching from any direction — see the definition in the dictionary.

*Note 2* **Traffic** is defined in the dictionary.

### 38 Giving way when making a U-turn

A driver making a U-turn must give way to all vehicles and pedestrians.

Offence provision.

*Note* For this rule, **give way** means the driver must slow down and, if necessary stop, to avoid a collision — see the definition in the dictionary.

### 39 Making a U-turn contrary to a no U-turn sign

- (1) A driver must not make a U-turn at a break in a dividing strip on a road if there is a *no U-turn sign* at the break in the dividing strip.

Offence provision.

*Note 1* **Dividing strip** is defined in the dictionary.

*Note 2* Rule 322 (5) and (6) deal with the meaning of a traffic sign **at** a break in a dividing strip.

- (2) A driver must not make a U-turn on a length of road to which a *no U-turn sign* applies.

Offence provision.

*Note* **Length** of road is defined in the dictionary.

- (3) A *no U-turn sign* on a road (except a *no U-turn sign* at an intersection or at a break in a dividing strip) applies to the length of road beginning at the sign and ending at the nearer of the following:

- (a) the next intersection on the road;
- (b) if the road ends at a T-intersection or dead end — the end of the road.

*Note 1* **Intersection** and **T-intersection** are defined in the dictionary.

*Note 2* Rule 322 (1) and (2) deal with the meaning of a traffic sign **on** a road.

No U-turn signs

No U-turn sign  
(Standard sign)



No U-turn sign  
(Variable illuminated message sign)



*Note for diagrams* There is another permitted version of each of these *no U-turn signs* — see the diagrams in Schedule 3.

#### 40 Making a U-turn at an intersection with traffic lights

A driver must not make a U-turn at an intersection with traffic lights unless there is a *U-turn permitted sign* at the intersection.

Offence provision.

*Note* *Intersection* and *traffic lights* are defined in the dictionary.

U-turn permitted sign

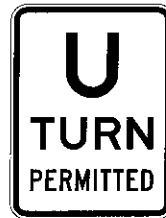

#### 41 Making a U-turn at an intersection without traffic lights

A driver must not make a U-turn at an intersection without traffic lights if there is a *no U-turn sign* at the intersection.

Offence provision.

*Note 1* *Intersection* and *traffic lights* are defined in the dictionary.

*Note 2* U-turns are permitted at intersections without traffic lights unless there is a *no U-turn sign*, even though traffic lane arrows indicate that the driver must or may turn right — see rule 92.

#### 42 Starting a U-turn at an intersection

A driver making a U-turn at an intersection must start the U-turn:

- (a) if the road where the driver is turning has a dividing line or median strip — from the marked lane nearest, or as near as practicable, to the dividing line or median strip; or

(b) in any other case — from the left of the centre of the road.

Offence provision.

*Note* *Centre of the road, dividing line, intersection, marked lane* and *median strip* are defined in the dictionary.

*Example*

Starting a U-turn on a road with a median strip

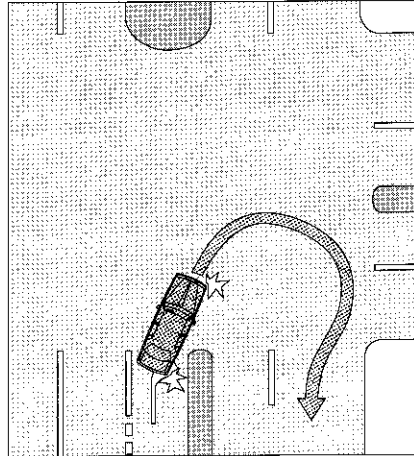

## **Division 5 Turns into or from road-related areas or adjacent land**

### **43 Starting and making turns**

- (1) A driver turning left from a road into a road-related area or adjacent land, or from a road-related area into a road, must comply with Division 1 as if the driver were turning left at an intersection.

Offence provision.

*Note 1* **Adjacent land** is defined in the dictionary, and **road-related area** is defined in rule 13. Adjacent land or a road-related area can include a driveway, service station or shopping centre — see the definitions. Some shopping centres may include roads — see the definition of **road** in rule 12.

*Note 2* For the meaning of **left** and **right**, see rule 351 (1) and (2).

- (2) A driver turning right from a road into a road-related area or adjacent land, or from a road-related area into a road, must comply with Division 2 as if the driver were turning right at an intersection.

Offence provision.

- (3) In this rule:

**road** does not include a road-related area.

*Note 1* A **road-related area** includes the shoulder of a road — see rule 13.

*Note 2* Rule 74 deals with the give way rules applying to a driver entering a road from a road-related area or adjacent land, and rule 75 deals with the give way rules applying to a driver entering a road-related area or adjacent land from a road.

*Note 3* Rule 212 deals with a driver entering and leaving a median strip parking area.

## Part 5 Change of direction and stop signals

### Division 1 Change of direction signals

#### 44 Division does not apply to entering or leaving a roundabout

This Division does not apply to a driver entering, in or leaving a roundabout.

*Note* Part 9 deals with giving change of direction signals when entering or leaving a roundabout.

#### 45 What is changing direction

- (1) A driver *changes direction* if the driver changes direction to the left or the driver changes direction to the right.
- (2) A driver *changes direction to the left* by doing any of the following:
  - (a) turning left;
  - (b) changing marked lanes to the left;
  - (c) diverging to the left;
  - (d) entering a marked lane, or a line of traffic, to the left;
  - (e) moving to the left from a stationary position;
  - (f) turning left into a marked lane, or a line of traffic, from a median strip parking area;
  - (g) at a T-intersection where the continuing road curves to the right—leaving the continuing road to proceed straight ahead onto the terminating road.

*Note 1* *Marked lane* and *median strip parking area* are defined in the dictionary.

*Note 2* For the meaning of *left*, see rule 351 (1).

- (3) A driver *changes direction to the right* by doing any of the following:
  - (a) turning right;
  - (b) changing marked lanes to the right;
  - (c) diverging to the right;
  - (d) entering a marked lane, or a line of traffic, to the right;
  - (e) moving to the right from a stationary position;
  - (f) turning right into a marked lane, or a line of traffic, from a median strip parking area;
  - (g) making a U-turn;
  - (h) at a T-intersection where the continuing road curves to the left—leaving the continuing road to proceed straight ahead onto the terminating road.

*Note 1* *U-turn* is defined in the dictionary.

*Note 2* For the meaning of *right*, see rule 351 (2).

Examples for subrules (2) (g) and (3) (h)

Example 1

Driver indicating change of direction at a T-intersection where the continuing road curves to the right and the driver is proceeding straight ahead onto the terminating road

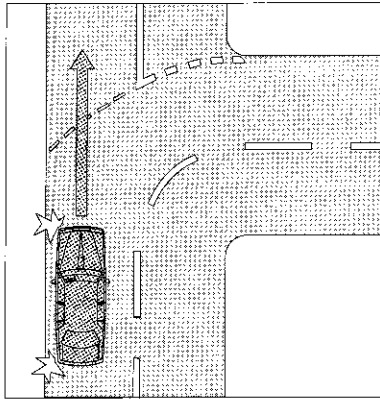

Example 2

Driver indicating change of direction at a T-intersection where the continuing road curves to the left and the driver is proceeding straight ahead onto the terminating road

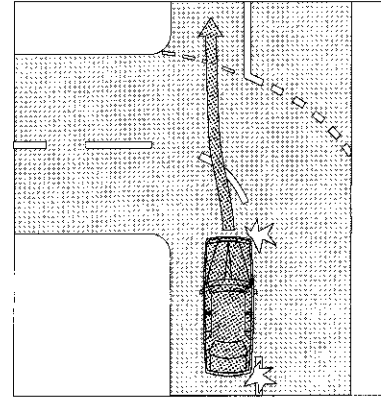

#### 46 Giving a left change of direction signal

- (1) Before a driver changes direction to the left, the driver must give a left change of direction signal in accordance with rule 47 for long enough to comply with subrule (2) and, if subrule (3) applies to the driver, that subrule.

Offence provision.

*Note* **Changes direction to the left** is defined in rule 45 (2).

- (2) The driver must give the change of direction signal for long enough to give sufficient warning to other drivers and pedestrians.
- (3) If the driver is about to change direction by moving from a stationary position at the side of the road or in a median strip parking area, the driver must give the change of direction signal for at least 5 seconds before the driver changes direction.

*Note* **Median strip parking area** is defined in the dictionary.

- (4) The driver must stop giving the change of direction signal as soon as the driver completes the change of direction.

Offence provision.

- (5) This rule does not apply to a driver if the driver's vehicle is not fitted with direction indicator lights.

*Note* **Driver's vehicle** is defined in the dictionary.

#### 47 How to give a left change of direction signal

The driver of a vehicle must give a left change of direction signal by operating the vehicle's left direction indicator lights.



#### **48 Giving a right change of direction signal**

- (1) Before a driver changes direction to the right, the driver must give a right change of direction signal in accordance with rule 49 for long enough to comply with subrule (2) and, if subrule (3) applies to the driver, that subrule.

Offence provision.

*Note* **Changes direction to the right** is defined in rule 45 (3).

- (2) The driver must give the change of direction signal for long enough to give sufficient warning to other drivers and pedestrians.
- (3) If the driver is about to change direction by moving from a stationary position at the side of the road or in a median strip parking area, the driver must give the change of direction signal for at least 5 seconds before the driver changes direction.

*Note* **Median strip parking area** is defined in the dictionary.

- (4) The driver must stop giving the change of direction signal as soon as the driver completes the change of direction.

Offence provision.

- (5) This rule does not apply to:
  - (a) the driver of a tram that is not fitted with direction indicator lights; or
  - (b) the rider of a bicycle making a hook turn.

*Note 1* **Bicycle** and **tram** are defined in the dictionary.

*Note 2* Rules 34 and 35 deal with bicycles making hook turns.

#### **49 How to give a right change of direction signal**

- (1) The driver of a vehicle must give a right change of direction signal by operating the vehicle's right direction indicator lights.
- (2) However, if the vehicle's direction indicator lights are not in working order or are not clearly visible, or the vehicle is not fitted with direction indicator lights, the driver must give the change of direction signal by giving a hand signal in accordance with rule 50, or using a mechanical signalling device fitted to the vehicle.

*Note* **Mechanical signalling device** is defined in the dictionary.

**50 How to give a right change of direction signal by giving a hand signal**

To give a hand signal for changing direction to the right, the driver must extend the right arm and hand horizontally and at right angles from the right side of the vehicle, with the hand open and the palm facing the direction of travel.

*Example*

Giving a hand signal for changing direction to the right

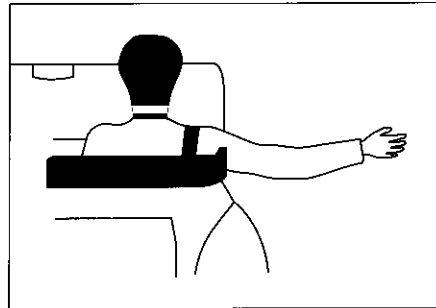

**51 When use of direction indicator lights permitted**

The driver of a vehicle must not operate a direction indicator light except:

- (a) to give a change of direction signal when the driver is required to give the signal under the *Australian Road Rules*; or
- (b) as part of the vehicle's hazard warning lights.

Offence provision.

*Note* Rule 221 deals with the use of hazard warning lights.

## **Division 2      Stop signals**

### **52      Division does not apply to bicycle riders or certain tram drivers**

This Division does not apply to the rider of a bicycle, or the driver of a tram that is not fitted with brake lights.

*Note* **Bicycle** and **tram** are defined in the dictionary.

### **53      Giving a stop signal**

- (1) A driver must give a stop signal in accordance with rule 54 before stopping or when suddenly slowing.

Offence provision.

- (2) If the driver is stopping, the driver must give the stop signal for long enough to give sufficient warning to other road users.

Offence provision.

- (3) If the driver is slowing suddenly, the driver must give the stop signal while slowing.

Offence provision.

### **54      How to give a stop signal**

- (1) The driver of a vehicle must give a stop signal by means of the vehicle's brake lights.
- (2) However, if the vehicle's brake lights are not in working order or are not clearly visible, or the vehicle is not fitted with brake lights, the driver must give the stop signal by giving a hand signal in accordance with rule 55, or using a mechanical signalling device fitted to the vehicle.

*Note* **Mechanical signalling device** is defined in the dictionary.

### **55      How to give a stop signal by giving a hand signal**

- (1) To give a hand signal for stopping or suddenly slowing, the driver must extend the right arm and hand at right angles from the right side of the vehicle, with the upper arm horizontal and the forearm and hand pointing upwards, and with the hand open and the palm facing the direction of travel.

**Rule 55**

---

- (2) However, the rider of a motor bike may give the hand signal by extending the left arm and hand at right angles from the left side of the motor bike, with the upper arm horizontal and the forearm and hand pointing upwards, and with the hand open and the palm facing the direction of travel.

*Note* **Motor bike** is defined in the dictionary.

*Example*

Giving a hand signal for stopping or suddenly slowing

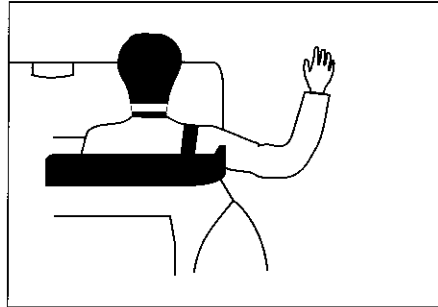

## Part 6 Traffic lights and twin red lights

### Division 1 Obeying traffic lights

*Note 1* **Traffic arrows** and **traffic lights** are defined in the dictionary. **Traffic arrows** are a traffic control device installed with traffic lights that are designed to show a traffic arrow, or 2 or more traffic arrows at different times — see the definition in the dictionary.

*Note 2* A reference in a rule of this Part to a green, yellow or red traffic light or traffic arrow is a reference to a steady green, yellow or red traffic light or traffic arrow, unless otherwise stated in the rule — see rule 323.

*Note 3* The rules dealing with T lights and B lights, which apply to drivers of trams and public buses, are in Part 17.

#### 56 Stopping for a red traffic light or arrow

- (1) A driver approaching or at traffic lights showing a red traffic light must stop:
- (a) if there is a stop line at or near the traffic lights — as near as practicable to, but before reaching, the stop line; or
  - (b) if there is a *stop here on red signal sign* at or near the traffic lights, but no stop line — as near as practicable to, but before reaching, the sign; or
  - (c) if there is no stop line or *stop here on red signal sign* at or near the traffic lights — as near as practicable to, but before reaching, the nearest or only traffic lights.

Offence provision.

*Note* **Red traffic light** and **stop line** are defined in the dictionary.

*Example for subrule (1) (b)*

Stopping at a stop here on red signal sign on a road  
the driver is entering

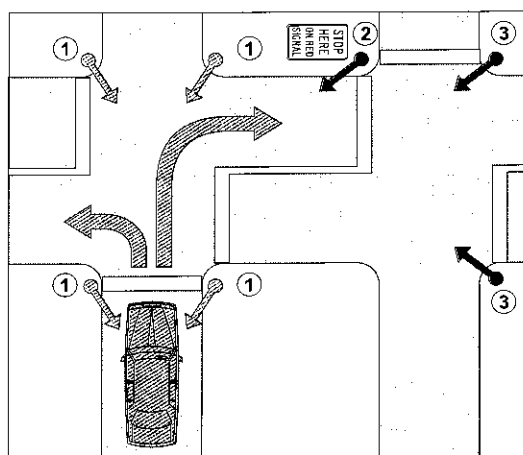

In this example, the driver may go straight ahead, or turn right or left, if there is a green traffic light showing at 1. However, the driver must not go beyond the stop line or *stop here on red signal sign* at 2, if there is a red traffic light showing on the road the driver is entering (see 3).

- (2) A driver approaching or at traffic arrows showing a red traffic arrow who is turning in the direction indicated by the arrow must stop:
- (a) if there is a stop line at or near the traffic arrows — as near as practicable to, but before reaching, the stop line; or
  - (b) if there is a *stop here on red arrow sign* at or near the traffic arrows, but no stop line — as near as practicable to, but before reaching, the sign; or
  - (c) if there is no stop line or *stop here on red arrow sign* at or near the traffic arrows — as near as practicable to, but before reaching, the nearest or only traffic arrows.

Offence provision.

*Note 1* **Red traffic arrow** is defined in the dictionary.

*Note 2* This rule only applies to a driver turning left using a slip lane if the red traffic light or red traffic arrow applies to the slip lane — see Part 20, Divisions 2 and 3, especially rules 330 and 345.

*Note 3* Rule 58 deals with when a driver does not have to stop for a red traffic light.

*Note 4* The driver of a tram or a public bus does not have to stop at traffic lights showing a red traffic light if a white T light (for trams) or a white B light (for public buses) is also showing, or a white traffic arrow is showing and the driver is turning in the direction indicated by the arrow — see rules 278 and 285.

Stop here on red signal sign



Stop here on red arrow sign

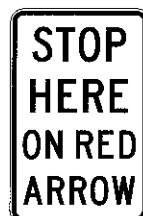

*Note for diagrams* There is another permitted version of the *stop here on red signal sign* — see the diagram in Schedule 3.

## **57 Stopping for a yellow traffic light or arrow**

- (1) This rule applies to:
- (a) a driver approaching or at traffic lights showing a yellow traffic light; or
  - (b) a driver approaching or at traffic arrows showing a yellow traffic arrow who is turning in the direction indicated by the arrow.

*Note* **Yellow traffic arrow** and **yellow traffic light** are defined in the dictionary.

- (2) The driver must stop:
- (a) if there is a stop line at or near the traffic lights or arrows and the driver can stop safely before reaching the stop line — as near as practicable to, but before reaching, the stop line; or
  - (b) if there is no stop line at or near the traffic lights or arrows and the driver can stop safely before reaching the traffic lights or arrows — as near as practicable to, but before reaching, the nearest or only traffic lights or arrows; or
  - (c) if the traffic lights or arrows are at an intersection and the driver cannot stop safely in accordance with paragraph (a) or (b), but can stop safely before entering the intersection — before entering the intersection.

Offence provision.

*Note* **Enter**, **intersection** and **stop line** are defined in the dictionary.

- (3) If the traffic lights or arrows are at an intersection and the driver is not able to stop safely under subrule (2) and enters the intersection, the driver must leave the intersection as soon as the driver can do so safely.

Offence provision.

*Note 1* **Intersection** does not include a road-related area — see the definition in the dictionary.

*Note 2* This rule only applies to a driver turning left using a slip lane if the yellow traffic light or yellow traffic arrow applies to the slip lane — see Part 20, Divisions 2 and 3, especially rules 330 and 345.

*Note 3* Rule 58 deals with when a driver does not have to stop at a yellow traffic light.

## **58 Exceptions to stopping for a red or yellow traffic light**

- (1) A driver approaching or at traffic lights showing a red or yellow traffic light does not have to stop if a green traffic arrow is also showing and the driver is turning in the direction indicated by the arrow.

*Note* **Green traffic arrow**, **red traffic light** and **yellow traffic light** are defined in the dictionary.

- (2) A driver turning at an intersection with traffic lights who approaches or is at a red traffic light on the road that the driver is entering does not have to stop for that traffic light if there is no stop line or *stop here on red signal sign* at or near the traffic light.

*Note* **Intersection** and **stop line** are defined in the dictionary.

## **59 Proceeding through a red traffic light**

- (1) If traffic lights at an intersection are showing a red traffic light, a driver must not enter the intersection.

Offence provision.

*Note 1* **Enter**, **intersection** and **red traffic light** are defined in the dictionary

*Note 2* Rules 56 and 57 deal with stopping for a red or yellow traffic light. Rule 60 deals with proceeding through a red traffic arrow.

- (2) However, if the traffic lights are at an intersection with a *left turn on red after stopping sign* and the driver is turning left at the intersection, the driver may turn left after stopping.

*Note* Rule 62 deals with the give way rules applying to a driver turning left at an intersection after stopping at a *left turn on red after stopping sign*.

- (3) Also, subrule (1) does not apply to a driver if subrule 58 (1) applies to the driver.

*Note* Rule 58 deals with when a driver does not have to stop for a red traffic light.

Left turn on red after stopping sign



## **60 Proceeding through a red traffic arrow**

If traffic arrows at an intersection are showing a red traffic arrow, and a driver is turning in the direction indicated by the arrow, the driver must not enter the intersection.

Offence provision.

*Note 1* **Enter**, **intersection** and **red traffic arrow** are defined in the dictionary.

*Note 2* Rules 56 and 57 deal with stopping for a red or yellow traffic arrow.

## **61 Proceeding when traffic lights or arrows at an intersection change to yellow or red**

(1) This rule applies to:

- (a) a driver at an intersection with traffic lights showing a green traffic light who has stopped after the stop line, *stop here on red signal sign*, or nearest or only traffic lights, at the intersection and is not making a hook turn at the intersection; or
- (b) a driver at an intersection with traffic arrows showing a green traffic arrow who is turning in the direction indicated by the arrow and has stopped after the stop line, *stop here on red arrow sign*, or nearest or only traffic arrows, at the intersection.

*Example*

A driver may stop after the stop line at an intersection with traffic lights showing a green traffic light, and not proceed through the intersection, because traffic is congested.

*Note 1* **Green traffic arrow**, **green traffic light**, **intersection** and **stop line** are defined in the dictionary.

*Note 2* Hook turns are dealt with in rules 34 and 35.

(2) If the traffic lights or arrows change to yellow or red while the driver is stopped and the driver has not entered the intersection, the driver must not enter the intersection.

Offence provision

*Note* **Enter** is defined in the dictionary.

(3) However, if the traffic lights are at an intersection with a *left turn on red after stopping sign* and the driver is turning left at the intersection, the driver may turn left after stopping.

*Note* Rule 62 deals with the give way rules applying to a driver turning left at an intersection after stopping at a *left turn on red after stopping sign*.

(4) Also, subrule (2) does not apply to a driver if subrule 58 (1) applies to the driver.

*Note* Rule 58 deals with when a driver does not have to stop for a red traffic light.

(5) If the traffic lights or arrows change to yellow or red while the driver is stopped and the driver has entered the intersection, the driver must leave the intersection as soon as the driver can do so safely.

Offence provision.

*Note* **Intersection** does not include a road-related area — see the definition in the dictionary.



## Division 2 Giving way at traffic lights

*Note* **Traffic lights** are defined in the dictionary.

### 62 Giving way when turning at an intersection with traffic lights

A driver turning at an intersection with traffic lights must give way to:

- (a) any pedestrian at or near the intersection who is on the road the driver is entering; and
- (b) if the driver is turning left at a *left turn on red after stopping sign* at the intersection:
  - (i) any vehicle approaching from the right, turning right at the intersection into the road the driver is entering or making a U-turn; and
  - (ii) any pedestrian at or near the intersection who is on the road the driver is leaving; and
- (c) if the driver is turning right — any oncoming vehicle that is going straight ahead or turning left at the intersection (except a vehicle turning left using a slip lane).

Offence provision.

*Note 1* **Intersection**, **oncoming vehicle**, **slip lane**, **straight ahead** and **U-turn** are defined in the dictionary.

*Note 2* For this rule, **give way** means the driver must remain stationary until it is safe to proceed — see the definition in the dictionary.

*Note 3* Rule 322 (3) and (4) deal with the meaning of a traffic sign **at** an intersection.

*Note 4* A driver turning left at a *left turn on red after stopping sign*, at an intersection with traffic lights showing a red traffic light, must stop in accordance with rule 56 (1) before making the turn.

*Examples*

Example 1

Giving way to a pedestrian on the road the driver is entering

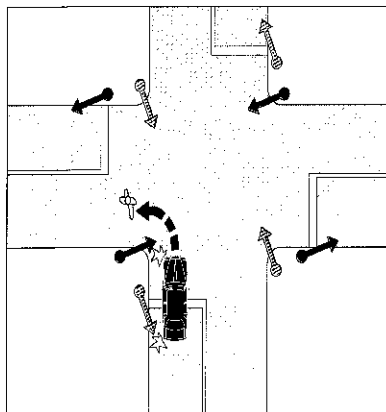

Example 2

Driver turning right giving way to an oncoming vehicle going straight ahead

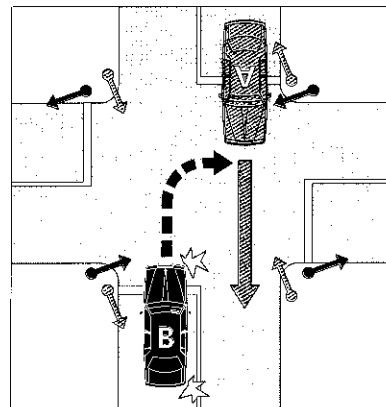

Example 3

Driver turning right does not have to give way to an oncoming vehicle that is turning left into the road the driver is entering using a slip lane

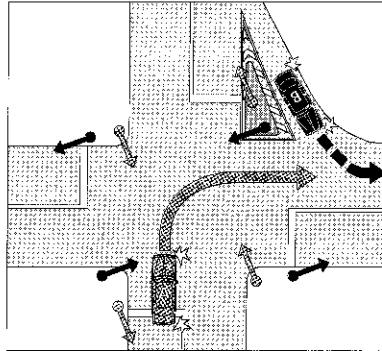

In example 1, the vehicle must give way to the pedestrian.

In examples 2 and 3, vehicle B must give way to vehicle A.

**63 Giving way at an intersection with traffic lights not operating or only partly operating**

- (1) This rule applies to a driver at an intersection if traffic lights at the intersection are not operating, or the traffic lights are showing only a flashing yellow traffic light.

*Note* **Intersection** and **yellow traffic light** are defined in the dictionary.

- (2) If there is a *traffic light-stop sign* at the intersection, the driver must comply with rule 67 as if the sign were a *stop sign* at an intersection without traffic lights.

Offence provision.

*Note 1* Rule 322 (3) and (4) deal with the meaning of a traffic sign *at* an intersection.

*Note 2* Rule 67 deals with stopping and giving way at a *stop sign* or stop line at an intersection without traffic lights.

*Note 3* There is no requirement under Division 1 of this Part for a driver to stop for a flashing yellow traffic light or traffic lights that are not operating.

- (3) If there is no *traffic light-stop sign* at the intersection, the driver must give way to vehicles and pedestrians at or near the intersection in accordance with rule 72 or 73 as if the intersection were an intersection without traffic lights, or a *stop sign*, stop line, *give way sign* or give way line.

Offence provision.

*Note 1* **Give way line** and **stop line** are defined in the dictionary.

*Note 2* Rules 72 and 73 deal with giving way at an intersection (except a roundabout) without traffic lights, or a *stop sign*, stop line, *give way sign* or give way line applying to the driver.

Traffic light-stop sign



#### **64 Giving way at a flashing yellow traffic arrow at an intersection**

A driver turning in the direction indicated by a flashing yellow traffic arrow at an intersection with traffic lights must give way to:

- (a) any vehicle travelling on the road the driver is entering; and
- (b) any pedestrian at or near the intersection who is on the road the driver is entering; and
- (c) if the driver is turning right — any oncoming vehicle that is going straight ahead or turning left at the intersection (except a vehicle turning left using a slip lane).

Offence provision.

*Note 1* **Intersection**, **oncoming vehicle**, **slip lane**, **straight ahead** and **yellow traffic arrow** are defined in the dictionary.

*Note 2* For this rule, **give way** means the driver must slow down and, if necessary, stop to avoid a collision — see the definition in the dictionary.

*Note 3* There is no requirement under Division 1 of this Part for a driver to stop for a flashing yellow traffic arrow.

#### **65 Giving way at a marked foot crossing (except at an intersection) with a flashing yellow traffic light**

- (1) This rule applies to a driver approaching or at a marked foot crossing (except at or near an intersection) with a flashing yellow traffic light at the crossing.

*Note* **Intersection**, **marked foot crossing** and **yellow traffic light** are defined in the dictionary.

- (2) The driver must:
  - (a) give way to any pedestrian on the crossing; and
  - (b) not obstruct any pedestrian on the crossing; and
  - (c) not overtake or pass a vehicle that is travelling in the same direction as the driver and is stopping, or has stopped, to give way at the crossing.

Offence provision.

*Note 1* **Overtake** is defined in the dictionary.

*Note 2* For subrule (2), **give way** means the driver must slow down and, if necessary, stop to avoid a collision — see the definition in the dictionary.

- (3) If there is no pedestrian on the crossing, and no other vehicle travelling in the same direction as the driver that is stopping, or has stopped, to give way at the crossing, the driver may proceed through the crossing.

## **Division 3 Twin red lights (except at level crossings)**

### **66 Stopping for twin red lights (except at level crossings)**

- (1) A driver approaching or at twin red lights on a road (except at a level crossing) must stop in accordance with subrules (2) and (3).

Offence provision.

*Note 1* **Level crossing** is defined in rule 120, and **twin red lights** is defined in the dictionary.

*Note 2* Rule 322 (1) and (2) deal with the meaning of a traffic control device **on** a road.

*Note 3* Twin red lights are generally erected at bridges, ambulance stations, fire stations or level crossings. The rules about stopping at level crossings are in Part 10.

- (2) If there is a stop line at or near the lights and the driver can stop safely before reaching the stop line, the driver must stop as near as practicable to, but before reaching, the stop line.

*Note* **Stop line** is defined in the dictionary.

- (3) If there is no stop line at or near the lights and the driver can stop safely before reaching the lights, the driver must stop as near as practicable to, but before reaching, the lights.

- (4) If the driver stops for the lights, the driver must not proceed until the lights are not showing.

Offence provision.

## Part 7 Giving way

*Note 1* The rules in this Part deal with giving way in most situations. In addition, other rules requiring a driver to give way include:

- making a U-turn — rule 38
- turning at traffic lights at an intersection — rule 62
- at an intersection with traffic lights that are not operating or only partly operating — rule 63
- turning at a flashing yellow traffic arrow at an intersection — rule 64
- at a marked foot crossing with a flashing yellow traffic light — rule 65
- entering and driving in a roundabout — rule 114
- by the rider of a bicycle or animal to a vehicle leaving a roundabout — rule 119
- at a *stop sign* at a level crossing — rule 121
- at a *give way sign* or give way line at a level crossing — rule 122
- moving from one marked lane to another marked lane, or from one line of traffic to another line of traffic — rule 148
- when lines of traffic merge into a single line of traffic — rule 149
- for pedestrians crossing the road near a stopped tram — rule 164.

*Note 2* For the meaning of *left* and *right*, see rule 351 (1) and (2).

### Division 1 Giving way at a stop sign, stop line, give way sign or give way line applying to the driver

*Note* For a driver, a reference in a rule in this Division to a traffic sign or road marking is a reference to a traffic sign or road marking applying to the driver—see rules 338 to 341.

#### 67 Stopping and giving way at a stop sign or stop line at an intersection without traffic lights

- (1) A driver at an intersection with a *stop sign* or stop line, but without traffic lights, must stop and give way in accordance with this rule.

Offence provision.

*Note 1* **Intersection** and **stop line** are defined in the dictionary. This rule applies also to T-intersections—see the definition of **intersection**.

*Note 2* For this rule, **give way** means the driver must remain stationary until it is safe for the driver to proceed—see the definition in the dictionary.

*Note 3* Part 6 deals with stopping and giving way at an intersection with traffic lights.

*Note 4* This rule only applies to a driver turning left using a slip lane if the *stop sign* or stop line applies to the slip lane—see Part 20, Divisions 2 and 3, especially rules 330 and 345.

- (2) The driver must stop at the stop line or, if there is no stop line, the driver must stop as near as practicable to, but before entering, the intersection.

*Note* **Enter** is defined in the dictionary.

- (3) The driver must give way to a vehicle in, entering or approaching the intersection except:
- (a) an oncoming vehicle turning right at the intersection if a *stop sign*, stop line, *give way sign* or give way line applies to the driver of the oncoming vehicle; or
  - (b) a vehicle turning left at the intersection using a slip lane; or
  - (c) a vehicle making a U-turn.

Note *Give way line*, *oncoming vehicle*, *slip lane* and *U-turn* are defined in the dictionary.

- (4) If the driver is turning left or right or making a U-turn, the driver must also give way to any pedestrian at or near the intersection on the road, or part of the road, the driver is entering.
- (5) For this rule, an oncoming vehicle travelling through a T-intersection on the continuing road is taken not to be turning.

Stop sign



*Examples*

Example 1  
Stop line

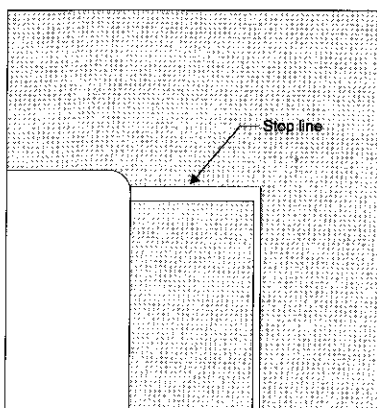

Example 2  
Stopping and giving way at a stop sign to vehicles on the left and right

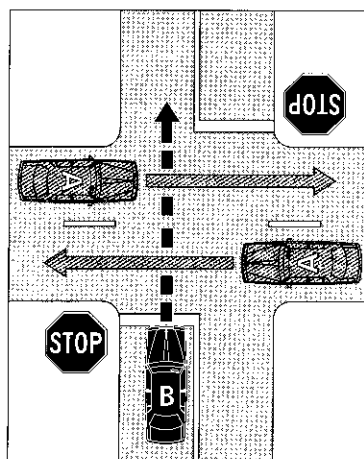

In example 2, vehicle B must stop and give way to each vehicle A.

**Example 3**  
Stopping and giving way at a stop sign to an oncoming vehicle at a stop sign

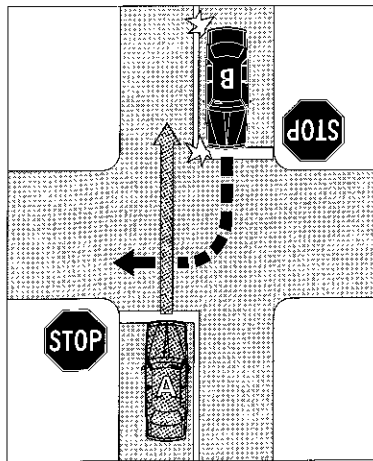

**Example 4**  
Stopping and giving way at a stop sign to an oncoming vehicle that is not at a stop sign or give way sign

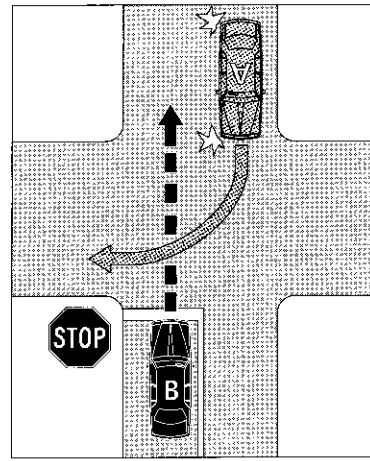

In examples 3 and 4, vehicle B must stop and give way to vehicle A.

## 68 Stopping and giving way at a stop sign or stop line at other places

- (1) A driver approaching or at a place (except an intersection, children's crossing, level crossing, or a place with twin red lights) with a *stop sign* or stop line must stop and give way in accordance with this rule.

Offence provision.

### Examples

1 A *stop sign* at a break in a dividing strip dividing the part of the road used by the main body of moving vehicles from a service road.

2 A *stop sign* on an exit from a carpark where the exit joins the road.

*Note 1* **Children's crossing** is defined in rule 80, **intersection**, **stop line** and **twin red lights** are defined in the dictionary, and **level crossing** is defined in rule 120.

*Note 2* For this rule, **give way** means the driver must remain stationary until it is safe for the driver to proceed — see the definition in the dictionary.

*Note 3* For the stopping and giving way rules applying to a driver at an intersection or level crossing with a *stop sign* or stop line, see rule 67 (intersections) and rule 121 (level crossings). Rule 80 deals with stopping at a stop line at a children's crossing.

- (2) The driver must stop at the stop line or, if there is no stop line, the driver must stop as near as practicable to, but before, the *stop sign*.
- (3) The driver must give way to any vehicle or pedestrian at or near the *stop sign*.

*Examples*

**Example 1**  
 Stopping and giving way at a stop sign at a break in a dividing strip

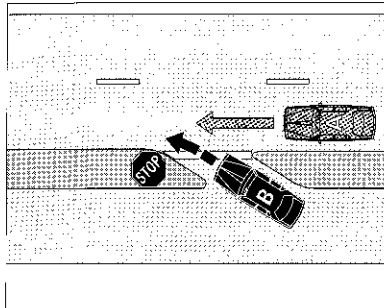

**Example 2**  
 Stopping and giving way at a stop sign where a carpark exit joins a road

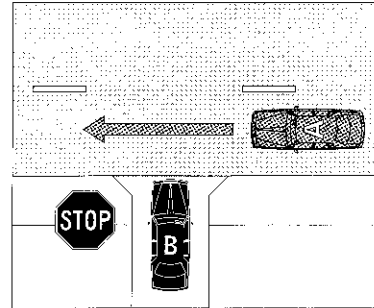

In each example, vehicle B must stop and give way to vehicle A.

**69 Giving way at a give way sign or give way line at an intersection**

- (1) A driver at an intersection with a *give way sign* or give way line must give way in accordance with this rule.

Offence provision.

*Note 1 Give way line and intersection* are defined in the dictionary. This rule applies also to T-intersections—see the definition of *intersection*.

*Note 2* For this rule, *give way* means the driver must slow down and, if necessary, stop to avoid a collision — see the definition in the dictionary.

- (2) The driver must give way to a vehicle in, entering or approaching the intersection except:
- (a) an oncoming vehicle turning right at the intersection if a *stop sign*, stop line, *give way sign* or give way line applies to the driver of the oncoming vehicle; or
  - (b) a vehicle turning left at the intersection using a slip lane; or
  - (c) a vehicle making a U-turn.

*Note Enter, oncoming vehicle, slip lane, stop line and U-turn* are defined in the dictionary.

- (3) If the driver is turning left or right or making a U-turn, the driver must also give way to any pedestrian at or near the intersection on the road, or part of the road, the driver is entering.
- (4) For this rule, an oncoming vehicle travelling through a T-intersection on the continuing road is taken not to be turning.

Give way sign





*Examples*

Example 1  
Give way line

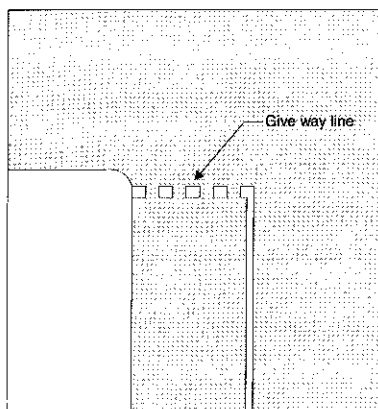

Example 2  
Giving way at a give way sign to vehicles on the left and right

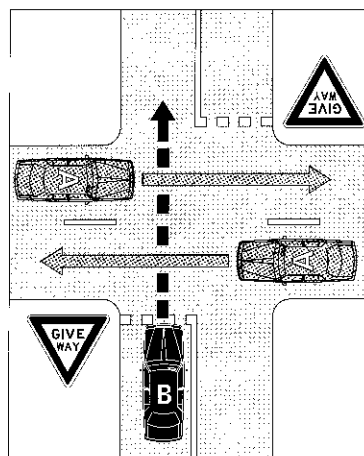

In example 2, vehicle B must give way to each vehicle A.

Example 3  
Giving way at a give way sign to an oncoming vehicle at a give way sign

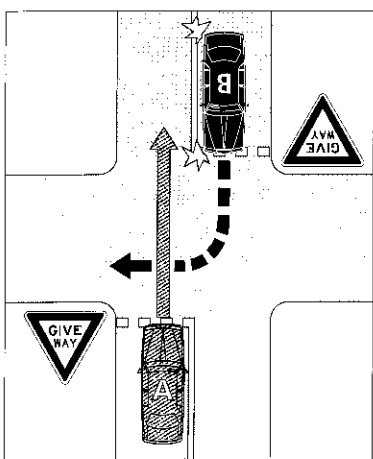

Example 4  
Giving way at a give way sign to an oncoming vehicle that is not at a stop sign or give way sign

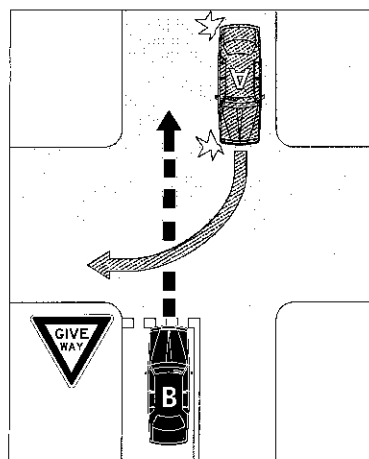

In examples 3 and 4, vehicle B must give way to vehicle A.

**Example 5**

Driver turning right at a give way line does not have to give way to a vehicle turning left using a slip lane

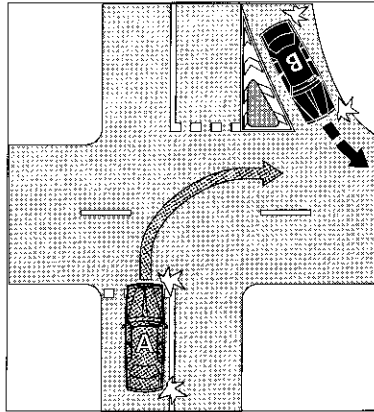

In example 5, vehicle B must give way to vehicle A.

**70 Giving way at a give way sign at a bridge or length of narrow road**

A driver approaching a bridge or length of narrow road with a *give way sign* must give way to any oncoming vehicle that is on the bridge or length of road when the driver reaches the sign.

Offence provision.

*Note 1* **Oncoming vehicle** is defined in the dictionary.

*Note 2* For this rule, *give way* means the driver must slow down and, if necessary, stop to avoid a collision — see the definition in the dictionary.

*Examples*

**Example 1**  
Giving way at a bridge

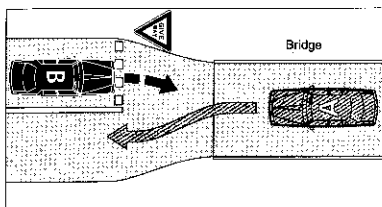

**Example 2**  
Giving way at a length of narrow road

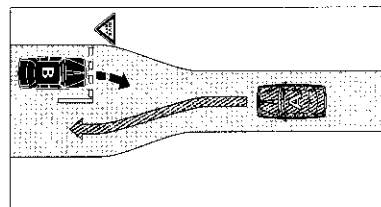

In each example, vehicle B must give way to vehicle A.

**71 Giving way at a give way sign or give way line at other places**

- (1) A driver approaching or at a place (except an intersection, bridge or length of narrow road, level crossing, or a place with twin red lights) with a *give way sign* or give way line must give way in accordance with this rule.

Offence provision.

*Examples*

- 1 A *give way sign* at a break in a dividing strip dividing the part of the road used by the main body of moving vehicles from a service road.
- 2 A *give way sign* on a road at a place where a bicycle path meets the road.

*Note 1* **Give way line, intersection** and **twin red lights** are defined in the dictionary, and **level crossing** is defined in rule 120.

*Note 2* For this rule, **give way** means the driver must slow down and, if necessary, stop to avoid a collision — see the definition in the dictionary.

*Note 3* For the give way rules applying to a driver at an intersection, bridge or length of narrow road, or level crossing, with a *give way sign* or give way line, see rule 69 (intersections), rule 70 (bridges and lengths of narrow road) and rule 122 (level crossings).

- (2) The driver must give way to any vehicle or pedestrian at or near the *give way sign* or give way line.

*Examples*

Example 1

Giving way at a give way sign at a break in a dividing strip

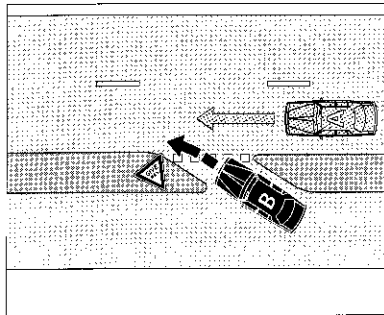

Example 2

Giving way at a give way sign where a bicycle path meets a road

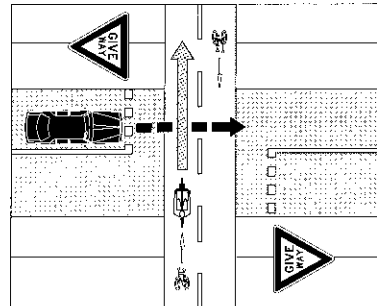

In example 1, vehicle B must give way to vehicle A.

In example 2, the motor vehicle must give way to the bicycle.

## Division 2 Giving way at an intersection without traffic lights or a stop sign, stop line, give way sign or give way line applying to the driver

*Note* For a driver, a reference in a rule in this Division to a traffic sign or road marking is a reference to a traffic sign or road marking applying to the driver—see rules 338 to 341.

### 72 Giving way at an intersection (except a T-intersection or roundabout)

- (1) A driver at an intersection (except a T-intersection or roundabout) without traffic lights or a *stop sign*, stop line, *give way sign* or give way line, must give way in accordance with this rule.

Offence provision.

*Note 1* *Give way line*, *intersection*, *stop line*, *T-intersection* and *traffic lights* are defined in the dictionary, and *roundabout* is defined in rule 109.

*Note 2* For this rule, *give way* means the driver must slow down and, if necessary, stop to avoid a collision — see the definition in the dictionary.

- (2) If the driver is going straight ahead, the driver must give way to any vehicle approaching from the right, unless a *stop sign*, stop line, *give way sign* or give way line applies to the driver of the approaching vehicle.

*Examples*

Example 1  
Driver going straight ahead giving way to a vehicle on the right that is going straight ahead

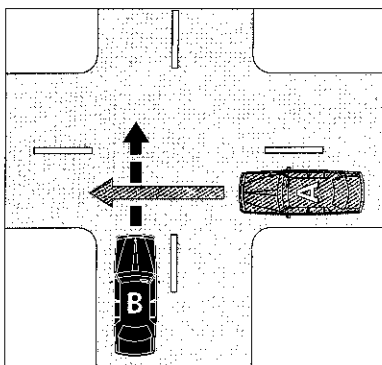

Example 2  
Driver going straight ahead giving way to a vehicle on the right that is turning right

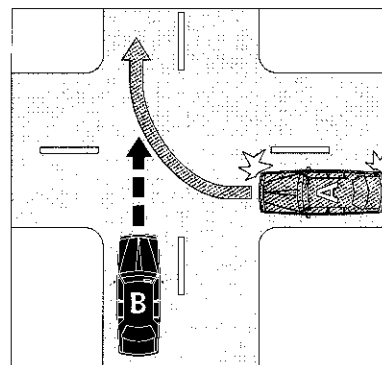

In each example, vehicle B must give way to vehicle A.

*Note* *Straight ahead* is defined in the dictionary.

- (3) If the driver is turning left (except if the driver is using a slip lane), the driver must give way to:
- any vehicle approaching from the right, unless a *stop sign*, stop line, *give way sign* or give way line applies to the driver of the approaching vehicle; and
  - any pedestrian at or near the intersection on the road the driver is entering.

*Examples*

Example 3

Driver turning left giving way to a vehicle on the right that is going straight ahead

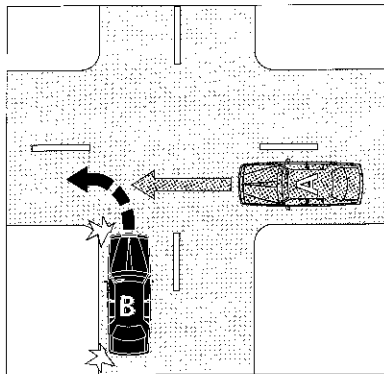

Example 4

Driver turning left giving way to a pedestrian on the road the driver is entering

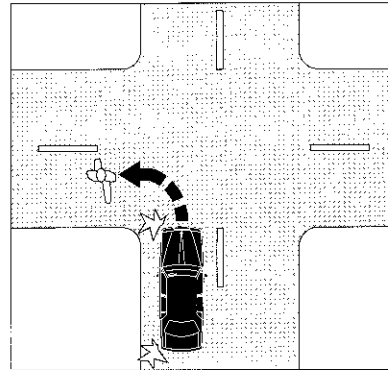

In example 3, vehicle B must give way to vehicle A.

In example 4, the vehicle must give way to the pedestrian.

*Note* **Slip lane** is defined in the dictionary.

- (4) If the driver is turning left using a slip lane, the driver must give way to:
- (a) any vehicle approaching from the right or turning right at the intersection into the road the driver is entering (except a vehicle making a U-turn at the intersection); and
  - (b) any pedestrian on the slip lane.

*Example*

Example 5

Driver turning left using a slip lane giving way to a vehicle that is turning right into the road the driver is entering

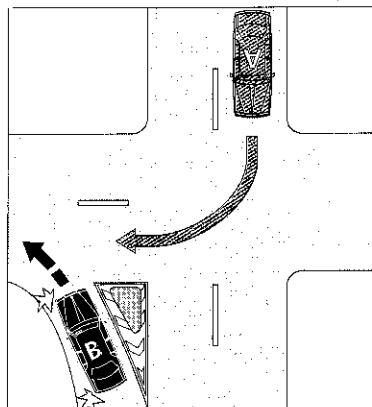

In this example, vehicle B must give way to vehicle A.

- (5) If the driver is turning right, the driver must give way to:
- (a) any vehicle approaching from the right, unless a *stop sign*, stop line, *give way sign* or give way line applies to the driver of the approaching vehicle; and
  - (b) any oncoming vehicle that is going straight ahead or turning left at the intersection, unless:
    - (i) a *stop sign*, stop line, *give way sign* or give way line applies to the driver of the oncoming vehicle; or

- (ii) the oncoming vehicle is turning left using a slip lane; and
- (c) any pedestrian at or near the intersection on the road the driver is entering.

*Note* **Oncoming vehicle** is defined in the dictionary.

*Examples*

**Example 6**

Driver turning right giving way to a vehicle on the right that is turning right into the road the driver is leaving

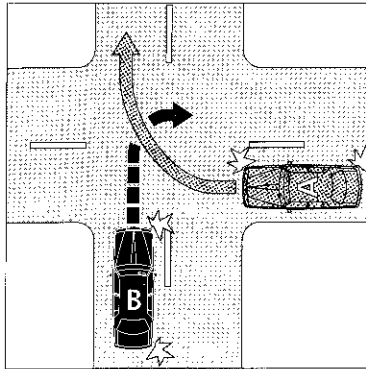

**Example 7**

Driver turning right giving way to an oncoming vehicle that is going straight ahead on the road the driver is leaving

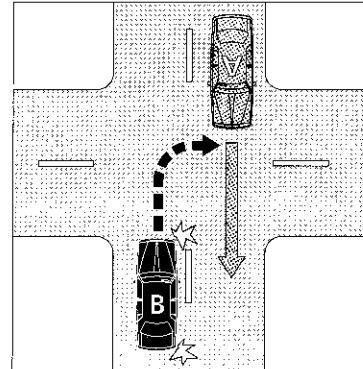

In examples 6 and 7, vehicle B must give way to vehicle A.

**Example 8**

Driver turning right giving way to an oncoming vehicle that is turning left into the road the driver is entering

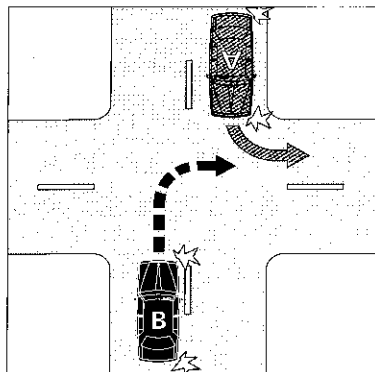

**Example 9**

Driver turning right giving way to a pedestrian on the road the driver is entering

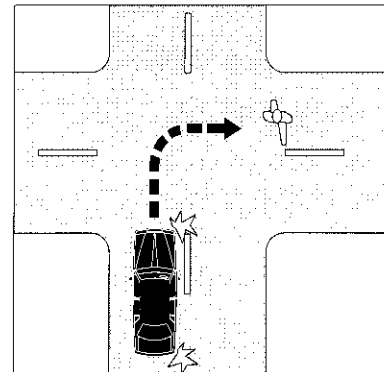

In example 8, vehicle B must give way to vehicle A.

In example 9, the vehicle must give way to the pedestrian.

**73 Giving way at a T-intersection**

- (1) A driver at a T-intersection without traffic lights or a *stop sign*, stop line, *give way sign* or give way line, must give way in accordance with this rule.

Offence provision.

*Note 1* **Give way line**, **stop line**, **T-intersection** and **traffic lights** are defined in the dictionary.

*Note 2* For this rule, *give way* means the driver must slow down and, if necessary, stop to avoid a collision — see the definition in the dictionary.

*Note 3* Rule 75 (1) (d) requires a driver at a T-intersection to give way when crossing the continuing road to enter a road-related area or adjacent land.

- (2) If the driver is turning left (except if the driver is using a slip lane) or right from the terminating road into the continuing road, the driver must give way to:
- (a) any vehicle travelling on the continuing road; and
  - (b) any pedestrian on the continuing road at or near the intersection.

*Note* *Continuing road*, *slip lane* and *terminating road* are defined in the dictionary.

*Examples*

Example 1

Driver turning right from the terminating road giving way to a vehicle on the continuing road

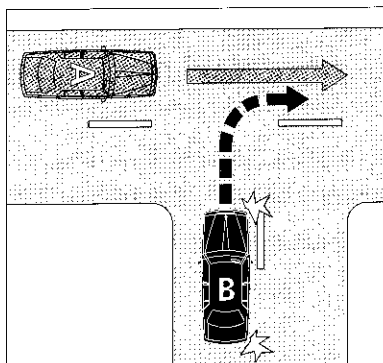

Example 2

Driver turning left (except if the driver is using a slip lane) from the terminating road giving way to a pedestrian on the continuing road

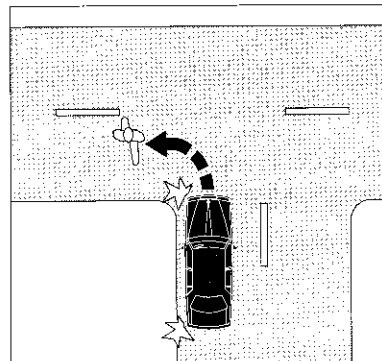

In example 1, vehicle B must give way to vehicle A.

In example 2, the vehicle must give way to the pedestrian.

- (3) If the driver is turning left from the terminating road into the continuing road using a slip lane, the driver must give way to:
- (a) any vehicle travelling on the continuing road; and
  - (b) any pedestrian on the slip lane.

**Rule 73**

- (4) If the driver is turning left (except if the driver is using a slip lane) from the continuing road into the terminating road, the driver must give way to any pedestrian on the terminating road at or near the intersection.

*Example*

Example 3

Driver turning left (except if the driver is using a slip lane) from the continuing road giving way to a pedestrian on the terminating road

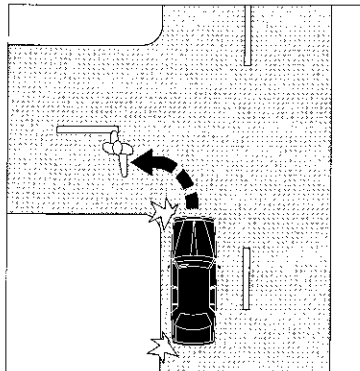

In this example, the vehicle must give way to the pedestrian.

- (5) If the driver is turning from the continuing road into the terminating road using a slip lane, the driver must give way to:
- (a) any vehicle approaching from the right; and
  - (b) any pedestrian on the slip lane.
- (6) If the driver is turning right from the continuing road into the terminating road, the driver must give way to:
- (a) any oncoming vehicle that is travelling through the intersection on the continuing road or turning left at the intersection; and
  - (b) any pedestrian on the terminating road at or near the intersection.

*Note* **Oncoming vehicle** is defined in the dictionary.

- (7) In this rule:

**turning left from the continuing road into the terminating road**, for a driver, includes, where the continuing road curves to the right at a T-intersection, leaving the continuing road to proceed straight ahead onto the terminating road.

**turning right from the continuing road into the terminating road**, for a driver, includes, where the continuing road curves to the left at a T-intersection, leaving the continuing road to proceed straight ahead onto the terminating road.

*Note* **Straight ahead** is defined in the dictionary.



*Examples*

Example 4

Driver turning right from the continuing road giving way to an oncoming vehicle travelling through the intersection on the continuing road

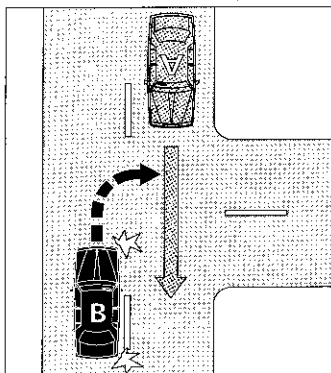

Example 5

Driver leaving the continuing road to proceed straight ahead on the terminating road giving way to a vehicle travelling through the intersection on the continuing road

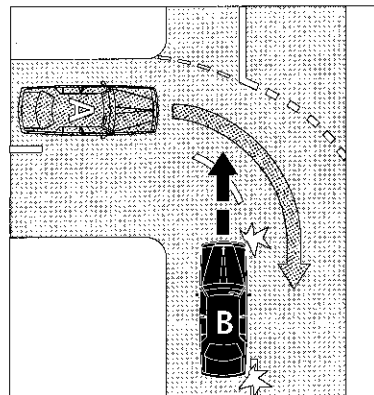

Example 5 shows a T-intersection where the continuing road (which is marked with broken white lines) goes around a corner. Vehicle B is leaving the continuing road to enter the terminating road. In examples 4 and 5, vehicle B must give way to vehicle A.

Example 6

Driver turning right from the continuing road giving way to an oncoming vehicle turning left from the continuing road

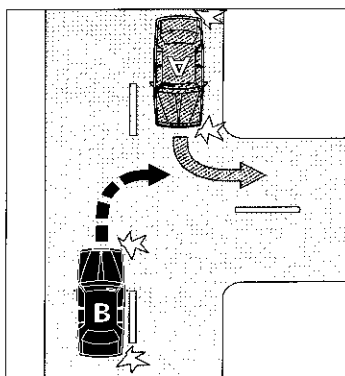

Example 7

Driver turning right from the continuing road giving way to a pedestrian on the terminating road

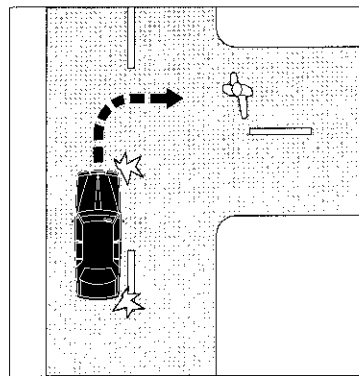

In example 6, vehicle B must give way to vehicle A.

In example 7, the vehicle must give way to the pedestrian.

## Division 3 Entering or leaving road-related areas and adjacent land

### 74 Giving way when entering a road from a road-related area or adjacent land

- (1) A driver entering a road from a road-related area, or adjacent land, without traffic lights or a *stop sign*, *stop line*, *give way sign* or give way line on the road or road-related area must give way to:
- (a) any vehicle travelling on the road or turning into the road (except a vehicle turning right into the road from a road-related area or adjacent land); and
  - (b) any pedestrian on the road; and
  - (c) any vehicle or pedestrian on any road-related area that the driver crosses to enter the road; and
  - (d) for a driver entering the road from a road-related area — any pedestrian on the road-related area.

Offence provision.

*Note 1* *Adjacent land*, *give way line*, *stop line* and *traffic lights* are defined in the dictionary, and *road-related area* is defined in rule 13.

*Note 2* Adjacent land or a road-related area can include a driveway, service station or shopping centre — see the definitions of *adjacent land* and *road-related area*. Some shopping centres may include roads — see the definition of *road* in rule 12.

*Note 3* Part 6 applies to the driver if there are traffic lights. Rule 68 applies to the driver if there is a *stop sign* or stop line, and rule 71 applies to the driver if there is a *give way sign* or give way line.

*Note 4* For this rule, *give way* means the driver must slow down and, if necessary, stop to avoid a collision — see the definition in the dictionary.

- (2) In this rule:

**road** does not include a road-related area.

*Note* A **road-related area** includes any shoulder of a road — see rule 13.

*Example*

Driver entering a road from a road-related area giving way to a pedestrian on the footpath and a vehicle on the road

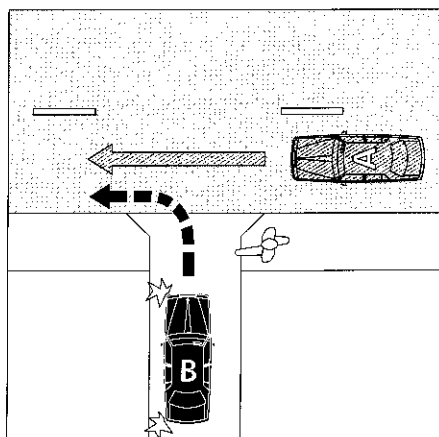

In this example, vehicle B must give way to the pedestrian on the footpath and to vehicle A.

**75 Giving way when entering a road-related area or adjacent land from a road**

- (1) A driver entering a road-related area or adjacent land from a place on a road without traffic lights or a *stop sign*, stop line, *give way sign* or give way line on the road or road-related area must give way to:
- (a) any pedestrian on the road; and
  - (b) any vehicle or pedestrian on any road-related area that the driver crosses or enters; and
  - (c) if the driver is turning right from the road — any oncoming vehicle on the road that is going straight ahead or turning left; and
  - (d) if the road the driver is leaving ends at a T-intersection opposite the road-related area or adjacent land and the driver is crossing the continuing road — any vehicle on the continuing road.

Offence provision.

*Note 1* *Adjacent land*, *continuing road*, *give way line*, *oncoming vehicle*, *stop line*, *straight ahead*, *T-intersection* and *traffic lights* are defined in the dictionary, and *road-related area* is defined in rule 13.

*Note 2* Adjacent land or a road-related area can include a driveway, service station or shopping centre — see the definitions of *adjacent land* and *road-related area*. Some shopping centres may include roads — see the definition of *road* in rule 12.

*Note 3* For this rule, *give way* means the driver must slow down and, if necessary, stop to avoid a collision — see the definition in the dictionary.

*Note 4* Part 6 applies to the driver if there are traffic lights. Rule 68 applies to the driver if there is a *stop sign* or stop line, and rule 71 applies to the driver if there is a *give way sign* or give way line.

- (2) In this rule:

*road* does not include a road-related area.

*Note* A *road-related area* includes any shoulder of a road — see rule 13.

*Examples*

Example 1

Driver turning right from a road into a road-related area giving way to an oncoming vehicle that is going straight ahead and to a pedestrian on the footpath

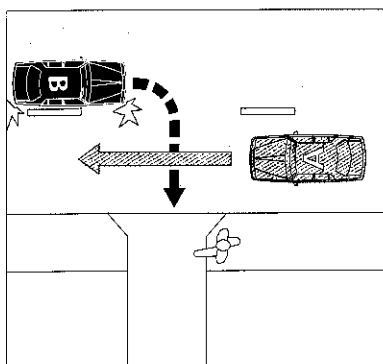

Example 2

Driver crossing a continuing road at a T-intersection to enter a road-related area giving way to a vehicle on the continuing road

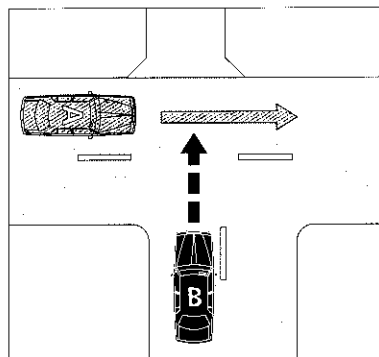

In each example, vehicle B must give way to vehicle A. In example 1, vehicle B must also give way to the pedestrian on the footpath.

## Division 4 Keeping clear of and giving way to particular vehicles

### 76 Keeping clear of trams travelling in tram lanes etc

- (1) A driver must not move into the path of an approaching tram travelling in a tram lane, or on tram tracks marked along the left side of the tracks by a broken or continuous yellow line parallel to the tracks.

Offence provision.

*Note* **Approaching**, **left**, **tram** and **tram tracks** are defined in the dictionary, and **tram lane** is defined in rule 155.

- (2) If a driver is in the path of an approaching tram travelling in a tram lane, or on tram tracks marked along the left side of the tracks by a broken or continuous yellow line parallel to the tracks, the driver must move out of the path of the tram as soon as the driver can do so safely.

Offence provision.

- (3) In this rule:

**tram** includes a bus travelling along tram tracks.

*Note* **Bus** and **travelling along tram tracks** are defined in the dictionary.

### 77 Giving way to buses

- (1) A driver driving on a length of road in a built-up area, in the left lane or left line of traffic, must give way to a bus in front of the driver if:
- (a) the bus has stopped, or is moving slowly, at the far left side of the road, on a shoulder of the road, or in a bus-stop bay; and
  - (b) the bus displays a *give way to buses sign* and the right direction indicator lights of the bus are operating; and
  - (c) the bus is about to enter or proceed in the lane or line of traffic in which the driver is driving.

Offence provision.

*Note 1* **Built-up area**, **bus** and **length** of road are defined in the dictionary, **left lane** and **left line of traffic** are defined in subrule (2), and **shoulder** is defined in rule 12.

*Note 2* For this rule, **give way** means the driver must slow down and, if necessary, stop to avoid a collision — see the definition in the dictionary.

*Note 3* The driver of the bus must give the change of direction signal for long enough to give sufficient warning to other drivers and pedestrians — see rule 48 (2) and (3).

*Note 4* Under rule 87 (1), a driver entering a marked lane, or a line of traffic, from the side of the road must give way to any vehicle travelling in the lane or line of traffic. However, the driver of a public bus does not have to give way to a vehicle if the vehicle is required to give way to the bus under this rule and it is safe for the bus to enter the lane, or line of traffic, in which the other vehicle is travelling — see rule 87 (2).

- (2) In this rule:

**left lane**, of a road, means:

- (a) the marked lane nearest to the far left side of the road (the **first lane**) or, if the first lane is a bicycle lane, the marked lane next to the first lane; or

- (b) if there is an obstruction in the first lane (for example, a parked car or roadworks) and the first lane is not a bicycle lane — the marked lane next to the first lane.

**left line of traffic**, for a road, means the line of traffic nearest to the far left side of the road.

*Note* **Marked lane** and **obstruction** are defined in the dictionary, and **bicycle lane** is defined in rule 153.

Give way to buses sign



*Note for diagram* This sign is displayed on buses.

## 78 Keeping clear of police and emergency vehicles

- (1) A driver must not move into the path of an approaching police or emergency vehicle that is displaying a flashing blue or red light (whether or not it is also displaying other lights) or sounding an alarm.

Offence provision.

*Note* **Approaching, emergency vehicle** and **police vehicle** are defined in the dictionary.

- (2) If a driver is in the path of an approaching police or emergency vehicle that is displaying a flashing blue or red light (whether or not it is also displaying other lights) or sounding an alarm, the driver must move out of the path of the vehicle as soon as the driver can do so safely.

Offence provision.

- (3) This rule applies to the driver despite any other rule of the *Australian Road Rules*.

## 79 Giving way to police and emergency vehicles

- (1) A driver must give way to a police or emergency vehicle that is displaying a flashing blue or red light (whether or not it is also displaying other lights) or sounding an alarm.

Offence provision.

*Note 1* **Emergency vehicle** and **police vehicle** are defined in the dictionary.

*Note 2* For this rule, **give way** means:

- (a) if the driver is stopped — remain stationary until it is safe to proceed; or  
(b) in any other case — slow down and, if necessary, stop to avoid a collision;  
— see the definition in the dictionary.

- (2) This rule applies to the driver despite any other rule that would otherwise require the driver of a police or emergency vehicle to give way to the driver.

## **Division 5 Crossings and shared zones**

### **80 Stopping at a children's crossing**

- (1) A driver approaching a children's crossing must drive at a speed at which the driver can, if necessary, stop safely before the crossing.

Offence provision.

*Note* **Children's crossing** is defined in subrule (6).

- (2) A driver approaching or at a children's crossing must stop at the stop line at the crossing if:
- (a) a *hand-held stop sign* is displayed at the crossing; or
  - (b) a pedestrian is on or entering the crossing.

Offence provision.

*Note 1* **Stop line** is defined in the dictionary.

*Note 2* Rule 322 (3) and (4) deal with the meaning of a traffic control device *at* a place.

- (3) If a driver stops at a children's crossing for a *hand-held stop sign*, the driver must not proceed until the holder of the sign:
- (a) no longer displays the sign towards the driver; or
  - (b) otherwise indicates that the driver may proceed.

Offence provision.

- (4) If a driver stops at a children's crossing for a pedestrian, the driver must not proceed until there is no pedestrian on or entering the crossing.

Offence provision.

- (5) For this rule, if a children's crossing extends across a road with a dividing strip, the part of the children's crossing on each side of the dividing strip is taken to be a separate children's crossing.

*Note* **Dividing strip** is defined in the dictionary.

- (6) A **children's crossing** is an area of a road:

- (a) at a place with stop lines marked on the road, and:
  - (i) children crossing flags; or
  - (ii) *children's crossing signs* and twin yellow lights; and
- (b) indicated by:
  - (i) 2 red and white posts erected on each side of the road; or
  - (ii) 2 parallel continuous or broken lines on the road surface from one side of the road completely or partly across the road; and
- (c) extending across the road between the posts or lines.

*Note* **Twin yellow lights** is defined in the dictionary.

Children crossing flag

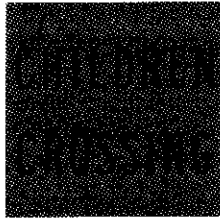

Children's crossing sign



Hand-held stop signs

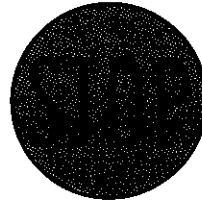

*Note 1 for diagrams* There is another permitted version of the *children's crossing sign* and a number of other permitted versions of the *hand-held stop signs* — see the diagrams in Schedule 3.

*Note 2 for diagrams* A *children's crossing sign* may have a different number on the sign — see rule 316 (4).

*Examples*

Example 1

Driver stopped at stop line for pedestrians on a children's crossing with children crossing flags

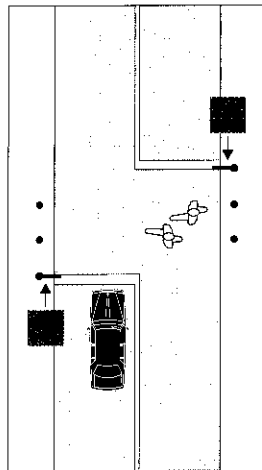

Example 2

Driver stopped at stop line for pedestrians on a children's crossing with children's crossing signs and twin yellow lights

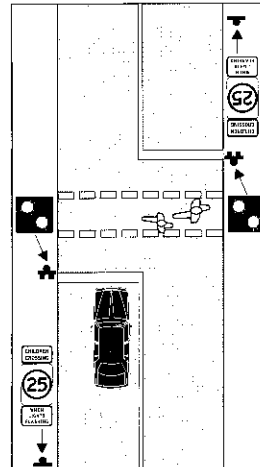

In each of these examples, the driver must stop at the stop line because there are pedestrians on the children's crossing.

### 81 Giving way at a pedestrian crossing

- (1) A driver approaching a pedestrian crossing must drive at a speed at which the driver can, if necessary, stop safely before the crossing.

Offence provision.

*Note* **Pedestrian crossing** is defined in subrule (3).

- (2) A driver must give way to any pedestrian on a pedestrian crossing.

Offence provision.

*Note* For this rule, **give way** means the driver must slow down and, if necessary, stop to avoid a collision — see the definition in the dictionary.

- (3) A **pedestrian crossing** is an area of a road:

- (a) at a place that has a **pedestrian crossing sign** (with or without alternating flashing twin yellow lights); and  
(b) indicated by white stripes on the road surface that are:  
(i) approximately parallel to each other; and  
(ii) from one side of the road completely or partly across the road.

*Note 1* **Twin yellow lights** is defined in the dictionary.

*Note 2* Rule 322 (3) and (4) deal with the meaning of a traffic sign **at** a place.

Pedestrian crossing sign



#### Examples

Example 1  
Giving way to a pedestrian on  
a pedestrian crossing

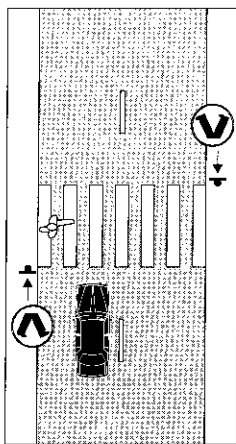

Example 2  
Giving way to a pedestrian on a pedestrian  
crossing at a slip lane

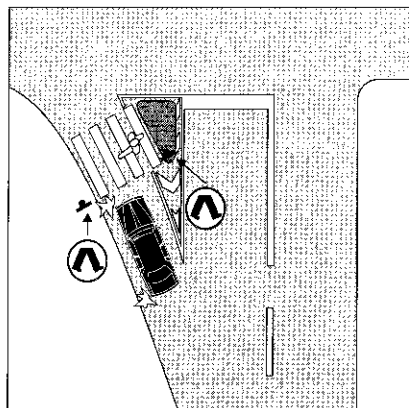

In each of these examples, the driver must give way to the pedestrian on the crossing.



## 82 Overtaking or passing a vehicle at a children's crossing or pedestrian crossing

A driver approaching a children's crossing, or pedestrian crossing, must not overtake or pass a vehicle that is travelling in the same direction as the driver and is stopping, or has stopped, to give way to a pedestrian at the crossing.

Offence provision.

*Note* **Children's crossing** is defined in rule 80, **overtake** is defined in the dictionary, and **pedestrian crossing** is defined in rule 81.

*Example*

Driver not passing a vehicle that has stopped to give way to a pedestrian at a pedestrian crossing

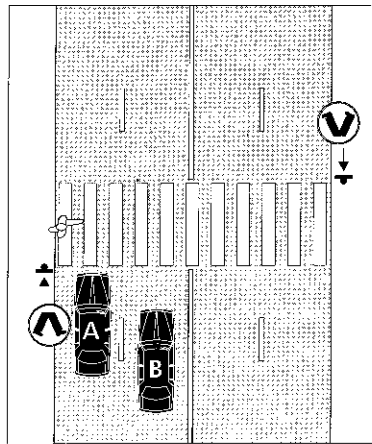

In the example, vehicle A has stopped to give way to a pedestrian on the crossing. Vehicle B must not overtake or pass vehicle A.

## 83 Giving way to pedestrians in a shared zone

A driver driving in a shared zone must give way to any pedestrian in the zone.

Offence provision.

*Note 1* **Shared zone** is defined in rule 24.

*Note 2* For this rule, **give way** means the driver must slow down and, if necessary, stop to avoid a collision — see the definition in the dictionary.

## Division 6 Other give way rules

### 84 Giving way when driving through a break in a dividing strip

- (1) If a driver drives through a break in a dividing strip that has no *stop sign*, stop line, *give way sign* or give way line, the driver must give way to:
- (a) any tram on the dividing strip; and
  - (b) any vehicle travelling on the part of the road the driver is entering (except a vehicle to which a *stop sign*, stop line, *give way sign*, or give way line, applies).

Offence provision.

*Note 1* **Dividing strip**, **give way line**, **stop line** and **tram** are defined in the dictionary.

*Note 2* Rule 68 applies to the driver if there is a *stop sign* or stop line, and rule 71 applies to the driver if there is a *give way sign* or give way line.

*Note 3* For this rule, *give way* means the driver must slow down and, if necessary, stop to avoid a collision — see the definition in the dictionary.

- (2) In this rule:

**tram** includes a bus travelling along tram tracks.

*Note* **Bus** and **travelling along tram tracks** are defined in the dictionary.

*Examples*

Example 1  
Giving way when driving through a break in a median strip

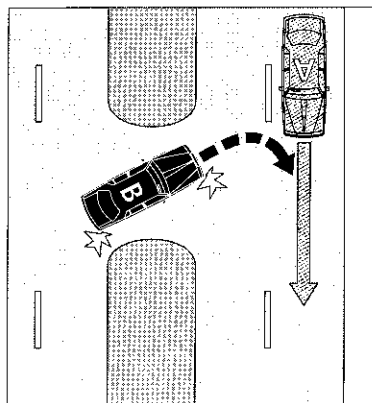

Example 2

Giving way when driving through a break in a dividing strip to leave a service road

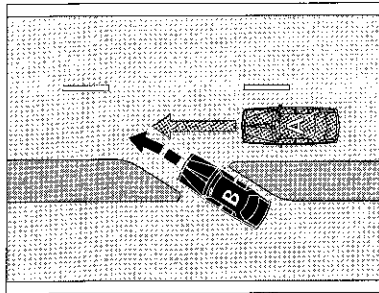

Example 3

Giving way when driving through a break in a dividing strip to enter a service road

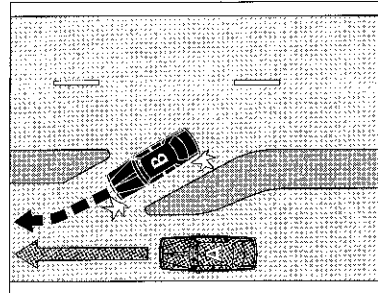

In each of the examples, vehicle B must give way to vehicle A.

*Note to examples* A median strip is a particular kind of dividing strip — see the definition of *median strip* in the dictionary.

## 85 Giving way on a painted island

A driver entering a turning lane from a painted island must give way to any vehicle:

- (a) in the turning lane; or
- (b) entering the turning lane from the marked lane, or line of traffic, immediately to the left of the turning lane.

Offence provision.

*Note 1* **Marked lane**, **painted island** and **turning lane** are defined in the dictionary.

*Note 2* Rule 138 deals with keeping off painted islands.

*Note 3* For this rule, **give way** means the driver must slow down and, if necessary, stop to avoid a collision — see the definition in the dictionary.

*Example*

Driver entering a turning lane from a painted island giving way to a vehicle entering the turning lane from the marked lane immediately to the left of the turning lane

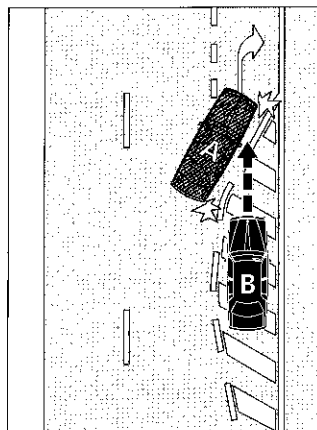

In the example, vehicle B must give way to vehicle A.

## 86 Giving way in median turning bays

- (1) A driver entering a median turning bay must give way to any oncoming vehicle already in the turning bay.

Offence provision.

*Note 1* **Oncoming vehicle** is defined in the dictionary.

*Note 2* For this rule, **give way** means the driver must slow down and, if necessary, stop to avoid a collision — see the definition in the dictionary.

- (2) In this rule:

**median turning bay** means a marked lane, or the part of a marked lane:

- (a) to which a **median turning lane sign** applies; or  
(b) where traffic lane arrows applying to the lane indicate that vehicles travelling in opposite directions must turn right.

*Note* **Marked lane** and **traffic lane arrows** are defined in the dictionary.

Median turning lane sign



*Note for diagram* There is another permitted version of the **median turning lane sign** — see the diagram in Schedule 3.

*Example*

Giving way in a median turning bay

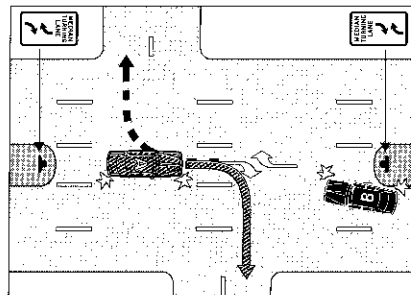

In the example, vehicle B must give way to vehicle A.

## 87 Giving way when moving from a side or shoulder of the road or a median strip parking area

- (1) A driver entering a marked lane, or a line of traffic, from the far left or right side of a road, or from a shoulder of a road, must give way to any vehicle travelling in the lane or line of traffic.

Offence provision.

*Note 1* **Marked lane** is defined in the dictionary, and **shoulder** is defined in rule 12.

*Note 2* For subrule (1), *give way* means:

- (a) if the driver is stopped — remain stationary until it is safe to proceed; or
- (b) in any other case — slow down and, if necessary, stop to avoid a collision;  
— see the definition in the dictionary.

- (2) However, the driver of a public bus does not have to give way to a vehicle if:
  - (a) the driver of the vehicle is required to give way to the bus under rule 77; and
  - (b) it is safe for the bus to enter the lane or line of traffic in which the vehicle is driving.

*Note 1* **Public bus** is defined in the dictionary.

*Note 2* The bus must display a *give way to buses sign* and the right direction indicator lights of the bus must be operating — see rule 77.

- (3) A driver turning from a median strip parking area into a marked lane, or a line of traffic, must give way to any vehicle travelling in the lane or line of traffic.

Offence provision.

*Note 1* **Median strip parking area** is defined in the dictionary.

*Note 2* For subrule (3), *give way* means the driver must slow down and, if necessary, stop to avoid a collision — see the definition in the dictionary.

***THIS PAGE INTENTIONALLY LEFT BLANK***

## Part 8 Traffic signs and road markings

*Note 1* The rules in this Part cover most traffic signs and road markings. However, some traffic signs and road markings are dealt with in other Parts dealing with particular subjects. These include:

- speed-limits (including speed-limits in speed-limited areas and shared zones) — see Part 3
- U-turns — see Part 4, Division 4
- traffic lights — see Part 6
- *stop signs* and *give way signs* — see Part 7, Division 1
- roundabouts — see Part 9
- level crossings — see Part 10
- keeping left and lane signs — see Part 11
- stopping and parking — see Part 12
- pedestrians — see Part 14
- bicycle riders — see Part 15.

*Note 2* Rule 322 deals with the meaning of traffic control devices *on* a road or *in* or *at* an area or place (including an intersection).

*Note 3* For a driver, a traffic sign or road marking mentioned in a rule is, unless the contrary intention appears, a sign or marking that applies to the driver. To find out how traffic signs and road markings apply to a driver, see rules 338 to 341.

### Division 1 Traffic signs and road markings at intersections

*Note* *Intersection*, *road marking* and *traffic sign* are defined in the dictionary.

#### 88 Left turn signs

- (1) If there is a *left turn only sign* at an intersection, a driver must turn left at the intersection.

Offence provision.

*Note* For the meaning of *left*, see rule 351 (1).

- (2) If there is a *left lane must turn left sign* at an intersection, a driver who is in the left marked lane when entering the intersection must turn left at the intersection.

Offence provision.

*Note* *Marked lane* is defined in the dictionary.

Left turn only sign



Left lane must turn left sign



*Note for diagrams* There is another permitted version of each of these signs — see the diagrams in Schedule 3.

## 89 Right turn signs

- (1) If there is a *right turn only sign* at an intersection, a driver must turn right at the intersection.

Offence provision.

*Note* For the meaning of *right*, see rule 351 (2).

- (2) If there is a *right lane must turn right sign* at an intersection, a driver who is in the right marked lane when entering the intersection must turn right at the intersection.

Offence provision.

*Note* **Marked lane** is defined in the dictionary.

- (3) In this rule:

**turn right** does not include make a U–turn.

*Note* **U–turn** is defined in the dictionary.

Right turn only sign



Right lane must turn right sign



*Note for diagrams* There are a number of other permitted versions of the *right turn only sign*, and another permitted version of the *right lane must turn right sign* — see the diagrams in Schedule 3.

## 90 No turns signs

If there is a *no turns sign* at an intersection, a driver must not turn left or right, or make a U–turn, at the intersection.

Offence provision.

*Note* **U–turn** is defined in the dictionary.

No turns sign



## 91 No left turn and no right turn signs

- (1) If there is a *no left turn sign* at an intersection, a driver must not turn left at the intersection.

Offence provision.



- (2) If there is a *no right turn sign* at an intersection, a driver must not turn right or make a U-turn at the intersection.

Offence provision.

No left turn signs

No left turn sign  
(Standard sign)



No left turn sign  
(Variable illuminated message sign)



No right turn signs

No right turn sign  
(Standard sign)



No right turn sign  
(Variable illuminated message sign)



*Note for diagrams* There is another permitted version of each of the *no left turn signs* and a number of other permitted versions of the *no right turn signs* — see the diagrams in Schedule 3.

## 92 Traffic lane arrows

- (1) If a driver is driving in a marked lane at an intersection (except a roundabout) and there are traffic lane arrows applying to the lane, the driver must:
- (a) if the arrows indicate a single direction — drive in that direction; or
  - (b) if the arrows indicate 2 or more directions — drive in one of those directions.

Offence provision.

*Note 1* **Marked lane** and **traffic lane arrows** are defined in the dictionary.

*Note 2* Part 9 deals with traffic lane arrows at roundabouts.

*Note 3* Rule 329 explains when a traffic control device applies to a marked lane.

- (2) However, this rule does not apply to a driver if the arrows indicate a direction to the right (whether or not they also indicate another direction) and the driver is making a U-turn at the intersection.

*Note* Rules 40 and 41 deal with making a U-turn at an intersection. If there are traffic lights at the intersection, the driver may make a U-turn only if there is a *U-turn permitted sign* at the intersection. If there are no traffic lights at the intersection, the driver may make a U-turn unless there is a *no U-turn sign* at the intersection.

*Examples*

Example 1  
Traffic lane arrows on the surface of marked lanes

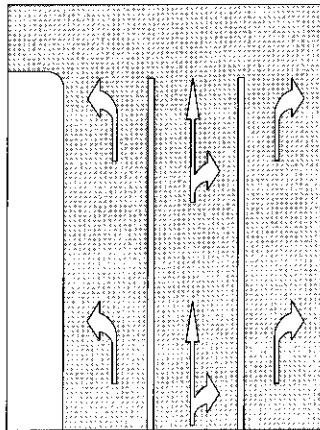

Example 2  
Traffic lane arrows on a traffic sign

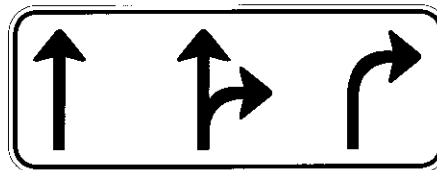

## Division 2 Traffic signs and road markings generally

### 93 No overtaking or passing signs

(1) A driver must not:

- (a) drive past a *no overtaking or passing sign* if any oncoming vehicle is on the bridge or length of road to which the sign applies; or
- (b) overtake a vehicle on a bridge or length of road to which a *no overtaking or passing sign* applies.

Offence provision.

*Note* **Oncoming vehicle** and **overtake** are defined in the dictionary.

(2) A *no overtaking or passing sign* on a road applies to the length of road (including a length of road on a bridge) beginning at the sign and ending:

- (a) if information on or with the sign indicates a distance — at that distance past the sign; or
- (b) if the sign applies to a bridge — at the end of the bridge; or
- (c) at an *end no overtaking or passing sign* on the road.

*Note* **With** is defined in the dictionary.

No overtaking or passing sign



End no overtaking or passing sign



### 94 No overtaking on bridge signs

A driver on a bridge with a *no overtaking on bridge sign* must not overtake a vehicle between the sign and the far end of the bridge.

Offence provision.

*Note* **Overtake** is defined in the dictionary.

No overtaking on bridge sign

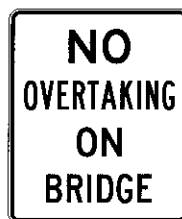

*Note for diagram* There is another permitted version of this sign — see the diagram in Schedule 3.

**Rule 95**

---

**95 Emergency stopping lane only signs**

- (1) A driver must not drive in an emergency stopping lane unless:
- (a) the driver needs to drive in the emergency stopping lane to avoid a collision, to stop in the lane, or because the driver's vehicle is disabled; or
  - (b) the driver is permitted to drive in the emergency stopping lane under another law of this jurisdiction.

Offence provision.

*Note 1* **Driver's vehicle** is defined in the dictionary.

*Note 2* Rule 178 deals with stopping in an emergency stopping lane.

- (2) This rule does not apply to the rider of a bicycle.

*Note 1* **Bicycle** is defined in the dictionary.

*Note 2* If a *no bicycles sign* applies to the emergency stopping lane, the rider must not ride in the lane — see rule 252.

- (3) In this rule:

**emergency stopping lane** means a marked lane, or the part of a marked lane, to which an *emergency stopping lane only sign* applies.

*Note 1* **Marked lane** is defined in the dictionary.

*Note 2* Rule 329 explains when a traffic control device applies to a marked lane.

Emergency stopping lane only sign



*Note for diagram* The sign may have an arrow pointing in a different direction — see rule 316 (4).

**96 Keep clear markings**

- (1) A driver must not stop on an area of a road marked with a keep clear marking.

Offence provision.

(2) In this rule:

**keep clear marking** means the words 'keep clear' marked across all or part of a road, with or without continuous lines marked across all or part of the road.

*Examples*

Example 1

Keep clear marking bounded by line road markings

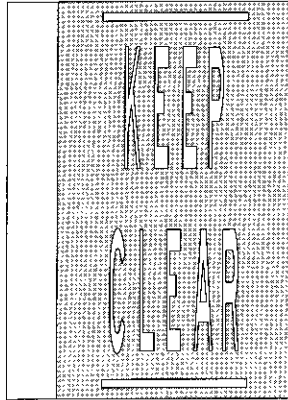

Example 2

Keep clear marking with no line road markings

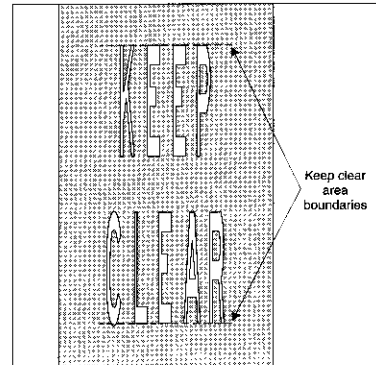

## 97 Road access signs

(1) A driver must not drive on a length of road to which a *road access sign* applies if information on or with the sign indicates that the driver or the driver's vehicle is not permitted beyond the sign.

Offence provision.

*Note* **Driver's vehicle**, **length** of road and **with** are defined in the dictionary.

(2) A *road access sign* on a road applies to the length of road beginning at the sign (including any road into which the length of road merges) and ending:

- (a) if the sign is on a freeway — at an *end freeway sign* or *end road access sign* on the road; or
- (b) if the sign is not on a freeway — at the nearer of the following:
  - (i) if the road ends at a T-intersection or dead end — the end of the road;
  - (ii) an *end road access sign* on the road.

*Example*

A *road access sign* on an access ramp to a freeway applies to the access ramp and the freeway into which the access ramp merges.

*Note 1* **Freeway** is defined in rule 177, and **road marking**, **T-intersection** and **traffic sign** are defined in the dictionary.

*Note 2* Rule 229 applies the *road access sign* to pedestrians.

Road access sign



End freeway sign



End road access sign



*Note 1 for diagrams* There are a number of other permitted versions of the *road access sign* and the *end freeway sign* — see the diagrams in Schedule 3.

*Note 2 for diagrams* A *road access sign* may indicate that it applies to different or additional vehicles or persons — see rule 316 (4).

**98 One-way signs**

- (1) A driver must not drive on a length of road to which a *one-way sign* applies except in the direction indicated by the arrow on the sign.

Offence provision.

*Note* **Length** of road is defined in the dictionary.

- (2) A *one-way sign* on a road applies to the length of road beginning at the sign and ending at the nearer of the following:
  - (a) a *two-way sign* on the road;
  - (b) a *keep left sign* on the road;
  - (c) another sign or road marking on the road that indicates that the road is a two-way road;
  - (d) if the road ends at a T-intersection — the end of the road.

*Note 1* **Road marking**, **T-intersection** and **two-way road** are defined in the dictionary.

*Note 2* There is a diagram of a *keep left sign* in rule 99.

One-way sign



Two-way sign

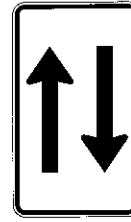

*Note 1 for diagrams* There are a number of other permitted versions of the *one-way sign* and another permitted version of the *two-way sign* — see the diagrams in Schedule 3.

*Note 2 for diagrams* A *one-way sign* may have an arrow pointing in a different direction — see rule 316 (4).

### 99 Keep left and keep right signs

- (1) A driver driving past a *keep left sign* must drive to the left of the sign.

Offence provision.

- (2) A driver driving past a *keep right sign* must drive to the right of the sign.

Offence provision.

Keep left sign



Keep right sign



*Note for diagrams* There is another permitted version of the *keep right sign* — see the diagram in Schedule 3.

### 100 No entry signs

A driver must not drive past a *no entry sign*.

Offence provision.

No entry sign



*Note for diagram* There are a number of other permitted versions of this sign — see the diagrams in Schedule 3.

### 101 Hand-held stop signs

- (1) A driver approaching a *hand-held stop sign* must stop before reaching the sign.

Offence provision.

- (2) The driver must not proceed until the holder of the sign:

- (a) no longer displays the sign towards the driver; or
- (b) otherwise indicates that the driver may proceed.

Offence provision.

- (3) This rule does not apply to a driver approaching or at a *hand-held stop sign* at a children's crossing.

*Note* Rule 80 defines *children's crossing*, and deals with *hand-held stop signs* at children's crossings.

Hand-held stop signs

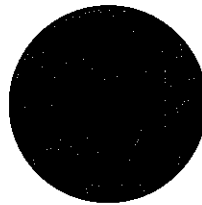

*Note for diagrams* There are a number of other permitted versions of this sign — see the diagrams in Schedule 3.



## Division 3 Signs for trucks, buses and other large vehicles

### 102 Clearance and low clearance signs

- (1) A driver must not drive past a *clearance sign*, or a *low clearance sign*, if the driver's vehicle, or any vehicle connected to it, is higher than the height (in metres) indicated by the sign.

Offence provision.

*Note* *Driver's vehicle* is defined in the dictionary.

- (2) In this rule:  
*vehicle* includes any load carried by the vehicle.

Clearance sign



Low clearance sign



### 103 Load limit signs

- (1) A driver must not drive past a *bridge load limit (gross mass) sign* or *gross load limit sign* if the total of the gross mass (in tonnes) of the driver's vehicle, and any vehicle connected to it, is more than the gross mass indicated by the sign.

Offence provision.

*Note* *Driver's vehicle* is defined in the dictionary.

- (2) A driver must not drive past a *bridge load limit (mass per axle group) sign* if the mass (in tonnes) carried by an axle group of the driver's vehicle, or any vehicle connected to it, is more than the mass indicated by the sign for the axle group.

Offence provision.

- (3) In this rule:  
*vehicle* includes any load carried by the vehicle.

Bridge load limit (gross mass) sign

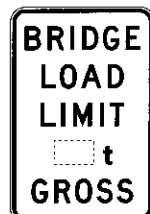

Gross load limit sign



Bridge load limit (mass per axle group) sign

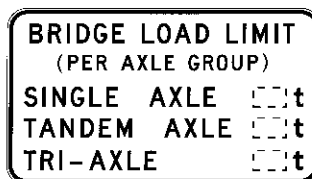

*Note for diagrams* There are a number of other permitted versions of the *bridge load limit (mass per axle group) sign* — see the diagrams in Schedule 3.

## 104 No trucks signs

- (1) A driver (except the driver of a bus) must not drive past a *no trucks sign* that has information on or with it indicating a mass if the GVM of the driver's vehicle (or, if the driver is driving a combination, any vehicle in the combination) is more than that mass, unless the driver is permitted to drive the vehicle on a route passing the sign under another law of this jurisdiction.

Offence provision.

*Note* **Bus**, **combination**, **driver's vehicle**, **GVM** and **with** are defined in the dictionary.

- (2) A driver (except the driver of a bus) must not drive past a *no trucks sign* that has information on or with it indicating a length if the length of the driver's vehicle (or, if the driver is driving a combination, the length of the combination) is longer than that length, unless the driver is permitted to drive the vehicle on a route passing the sign under another law of this jurisdiction.

Offence provision.

- (3) The driver of a truck must not drive past a *no trucks sign* that has no information on or with it indicating a mass or length, unless the driver is permitted to drive the truck on a route passing the sign under another law of this jurisdiction.

Offence provision.

*Note* **Truck** is defined in the dictionary.

No trucks sign



## 105 Trucks must enter signs

If the driver of a truck drives past a *trucks must enter sign*, the driver must enter the area indicated by information on or with the sign.

Offence provision.

*Note* **Truck** and **with** are defined in the dictionary.

Trucks must enter sign



*Note for diagram* There are a number of other permitted versions of this sign — see the diagrams in Schedule 3.

### 106 No buses signs

- (1) The driver of a bus must not drive past a *no buses sign* that has information on or with it indicating a mass if the GVM of the bus is more than that mass.

Offence provision.

*Note* **Bus**, **GVM** and **with** are defined in the dictionary.

- (2) The driver of a bus must not drive past a *no buses sign* that has information on or with it indicating a length if the bus is longer than that length.

Offence provision.

- (3) The driver of a bus must not drive past a *no buses sign* that has no information on or with it indicating a mass or length.

Offence provision.

No buses sign



### 107 Buses must enter signs

If the driver of a bus drives past a *buses must enter sign*, the driver must enter the area indicated by information on or with the sign.

Offence provision.

*Note* **Bus** and **with** are defined in the dictionary.

Buses must enter sign



*Note for diagram* There is another permitted version of this sign — see the diagram in Schedule 3.

### 108 Trucks and buses low gear signs

- (1) If the driver of a truck or bus is driving on a length of road to which a *trucks and buses low gear sign* applies, the driver must drive the truck or bus in a gear that is low enough to limit the speed of the truck or bus without the use of a primary brake.

Offence provision.

*Note* **Bus**, **length** of road and **truck** are defined in the dictionary.

- (2) Subrule (1) does not apply to the driver of a bus if information on or with the sign indicates that it applies only to trucks.

*Note* **With** is defined in the dictionary.

- (3) A *trucks and buses low gear sign* on a road applies to the length of road beginning at the sign and ending:
  - (a) if information on or with the sign indicates a distance — at that distance on the road from the sign; or
  - (b) in any other case — at an *end trucks and buses low gear sign* on the road.

- (4) In this rule:

**primary brake** means the footbrake, or other brake, fitted to a truck or bus that is normally used to slow or stop the vehicle.

Trucks and buses low gear sign



End trucks and buses low gear sign



*Note for diagrams* There are a number of other permitted versions of the *trucks and buses low gear sign*, and another permitted version of the *end trucks and buses low gear sign* — see the diagrams in Schedule 3.

## Part 9 Roundabouts

### 109 What is a roundabout

A *roundabout* is an intersection with:

- (a) one or more marked lanes, or lines of traffic, all of which are for the use of vehicles travelling in the same direction around a central traffic island; and
- (b) a *roundabout sign* at each entrance.

*Note 1* *Intersection*, *marked lane*, *traffic* and *traffic island* are defined in the dictionary.

*Note 2* Rule 322 (3) and (4) deal with the meaning of a traffic sign *at* a place.

Roundabout sign



### 110 Meaning of halfway around a roundabout

A driver leaves a roundabout *halfway around* the roundabout if the driver leaves the roundabout on a road that is straight ahead, or substantially straight ahead, from the road on which the driver enters the roundabout.

### 111 Entering a roundabout from a multi-lane road or a road with 2 or more lines of traffic travelling in the same direction

- (1) A driver entering a roundabout from a multi-lane road, or a road with 2 or more lines of traffic travelling in the same direction as the driver, must enter the roundabout in accordance with this rule.

Offence provision.

*Note* *Multi-lane road* is defined in the dictionary.

- (2) If the driver is to leave the roundabout less than halfway around it, the driver must enter the roundabout from the left marked lane or left line of traffic.

*Note* *Marked lane* is defined in the dictionary.

**Rule 111**

---

*Example*

Example 1

Leaving a roundabout less than halfway around it

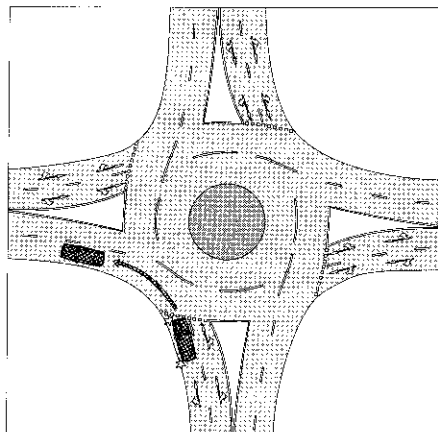

- (3) If the driver is to leave the roundabout more than halfway around it, the driver must enter the roundabout from the right marked lane or right line of traffic.

*Example*

Example 2

Leaving a roundabout more than halfway around it

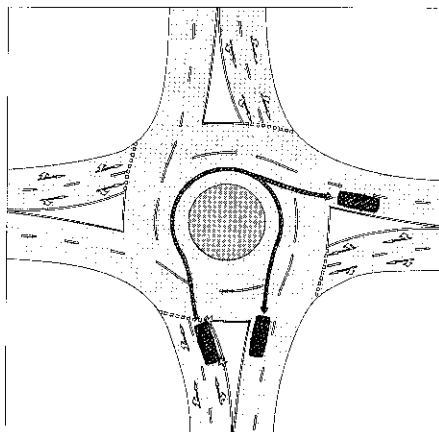

## Rule 111

- (4) If the driver is to leave the roundabout halfway around it, the driver may enter the roundabout from any marked lane or line of traffic.

*Example*

Example 3

Leaving a roundabout halfway around it

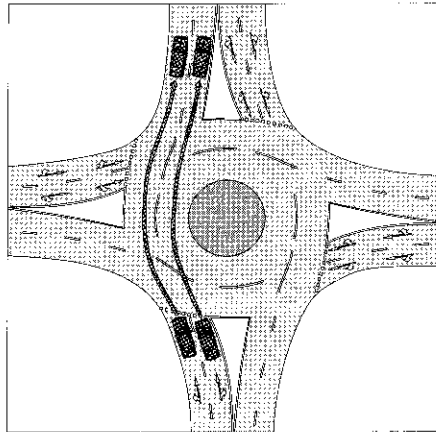

- (5) Despite subrules (2) to (4), if the driver is entering the roundabout from a marked lane and there are traffic lane arrows applying to the lane, the driver must:
- (a) if the arrows indicate a single direction — drive in that direction after entering the roundabout; or
  - (b) if the arrows indicate 2 or more directions — drive in one of those directions after entering the roundabout.

*Note* **Traffic lane arrows** is defined in the dictionary.

- (6) Subrule (3) does not apply to the rider of a bicycle or animal.

*Note* **Bicycle** is defined in the dictionary.

- (7) Subrule (5) does not apply to the rider of a bicycle or animal if the rider is to leave the roundabout more than halfway around it.

*Examples*

Example 4

Roundabout with 3 entry points

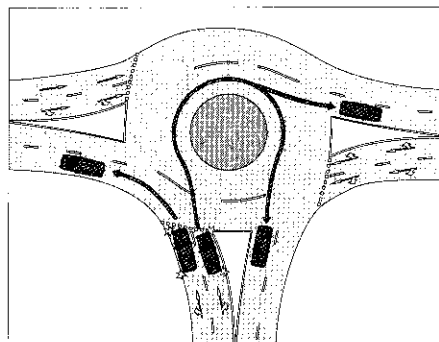

**Rule 112**

Example 5  
Roundabout with 5 entry points

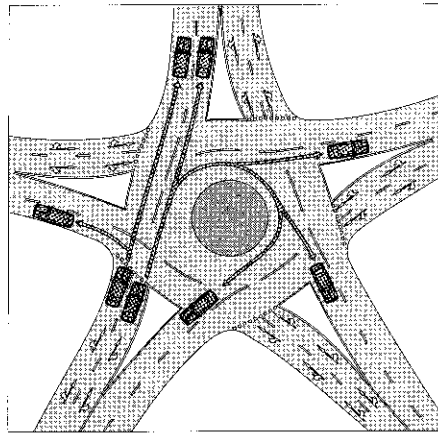

*Note 1 for examples 4 and 5* Rule 116 requires a driver to obey traffic lane arrows when driving in or leaving a roundabout.

*Note 2 for examples 4 and 5* The rules in Part 11 about driving in marked lanes, and moving from one marked lane or line of traffic, apply to a driver driving in a roundabout — see rules 146 to 148.

**112 Giving a left change of direction signal when entering a roundabout**

- (1) This rule applies to a driver entering a roundabout if:
  - (a) the driver is to leave the roundabout at the first exit after entering the roundabout; and
  - (b) the exit is less than halfway around the roundabout.
- (2) The driver must give a left change of direction signal when the driver is entering the roundabout.

Offence provision.

*Note* **Left change of direction signal** is defined in the dictionary.

- (3) The driver must continue to give the change of direction signal until the driver has left the roundabout.

Offence provision.

- (4) This rule does not apply to a driver if the driver's vehicle is not fitted with direction indicator lights.

*Note* **Driver's vehicle** is defined in the dictionary.

**113 Giving a right change of direction signal when entering a roundabout**

- (1) This rule applies to a driver entering a roundabout if the driver is to leave the roundabout more than halfway around it.
- (2) The driver must give a right change of direction signal when the driver is entering the roundabout.

Offence provision.

*Note* **Right change of direction signal** is defined in the dictionary.



**Rule 115**

- (3) The driver must continue to give the change of direction signal while the driver is driving in the roundabout, unless:
- (a) the driver is changing marked lanes, or entering another line of traffic; or
  - (b) the driver's vehicle is not fitted with direction indicator lights.

Offence provision.

*Note 1* **Driver's vehicle** and **marked lane** are defined in the dictionary.

*Note 2* Rule 117 deals with giving change of direction signals before changing marked lanes, or entering another line of traffic, in a roundabout.

**114 Giving way when entering or driving in a roundabout**

- (1) A driver entering a roundabout must give way to:
- (a) any vehicle in the roundabout; and
  - (b) a tram that is entering or approaching the roundabout.

Offence provision.

*Note 1* **Tram** is defined in the dictionary.

*Note 2* For this rule, **give way** means the driver must slow down and, if necessary, stop to avoid a collision — see the definition in the dictionary.

- (2) A driver driving in a roundabout must give way to a tram that is in, entering or approaching the roundabout.

Offence provision.

- (3) In this rule:

**tram** includes a bus travelling along tram tracks.

*Note 1* **Bus** and **travelling along tram tracks** are defined in the dictionary.

*Note 2* For the give way rules applying to a driver moving from one marked lane or line of traffic to another marked lane or line of traffic, see rule 148.

**115 Driving in a roundabout to the left of the central traffic island**

- (1) A driver driving in a roundabout must drive to the left of the central traffic island in the roundabout, unless subrule (2) or (3) applies to the driver.

Offence provision.

*Note* **Traffic island** is defined in the dictionary.

- (2) This subrule applies to a driver if:

- (a) the driver's vehicle is too large to drive in the roundabout without driving on the edge of the central traffic island; and
- (b) the driver can safely drive on the edge of the central traffic island.

*Note* **Driver's vehicle** is defined in the dictionary.

- (3) This subrule applies to a driver if:

- (a) the driver's vehicle is too large to drive in the roundabout without driving over the central traffic island; and
- (b) the central traffic island is designed to allow a vehicle of that kind to be driven over it.

**Rule 116**

---

**116 Obeying traffic lane arrows when driving in or leaving a roundabout**

If a driver is driving in a marked lane in a roundabout and there are traffic lane arrows applying to the lane, the driver must:

- (a) if the arrows indicate a single direction — drive in or leave the roundabout in that direction; or
- (b) if the arrows indicate 2 or more directions — drive in or leave the roundabout in one of those directions.

Offence provision.

*Note* **Marked lane** and **traffic lane arrows** are defined in the dictionary.

**117 Giving a change of direction signal when changing marked lanes or lines of traffic in a roundabout**

- (1) A driver driving in a roundabout must give a left change of direction signal before the driver changes marked lanes to the left, or enters a line of traffic to the left, in the roundabout, unless the driver's vehicle is not fitted with direction indicator lights.

Offence provision.

*Note* **Driver's vehicle** and **left change of direction signal** are defined in the dictionary.

- (2) A driver driving in a roundabout must give a right change of direction signal before the driver changes marked lanes to the right, or enters a line of traffic to the right, in the roundabout.

Offence provision.

*Note* **Right change of direction signal** is defined in the dictionary.

**118 Giving a left change of direction signal when leaving a roundabout**

- (1) If practicable, a driver driving in a roundabout must give a left change of direction signal when leaving the roundabout.

Offence provision.

*Note* **Left change of direction signal** is defined in the dictionary.

- (2) The driver must stop giving the change of direction signal as soon as the driver has left the roundabout.

Offence provision.

- (3) This rule does not apply to a driver if the driver's vehicle is not fitted with direction indicator lights.

*Note 1* **Driver's vehicle** is defined in the dictionary.

*Note 2* The rules in Part 11 about driving in marked lanes and moving from one marked lane or line of traffic to another marked lane or line of traffic apply to a driver leaving a roundabout — see rules 146 to 148.

---

**Rule 119****119 Giving way by the rider of a bicycle or animal to a vehicle leaving a roundabout**

The rider of a bicycle or animal who is riding in the far left marked lane of a roundabout with 2 or more marked lanes, or the far left line of traffic in a roundabout with 2 or more lines of traffic, must give way to any vehicle leaving the roundabout.

Offence provision.

*Note 1* **Bicycle** and **marked lane** are defined in the dictionary, and **vehicle** is defined in rule 15.

*Note 2* For this rule, **give way** means the rider must slow down and, if necessary, stop to avoid a collision — see the definition in the dictionary.

***THIS PAGE INTENTIONALLY LEFT BLANK***

## Part 10 Level crossings

### 120 What is a level crossing

(1) A *level crossing* is:

- (a) an area where a road and a railway meet at substantially the same level, whether or not there is a *level crossing sign* on the road at all or any of the entrances to the area; or
- (b) an area where a road and tram tracks meet at substantially the same level and that has a *level crossing sign* on the road at each entrance to the area.

*Note* **Tram tracks** is defined in the dictionary.

(2) In this rule:

**road** does not include a road-related area.

*Note* **Road-related area** is defined in rule 13.

Level crossing signs

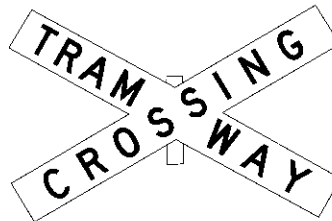
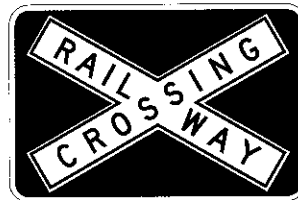
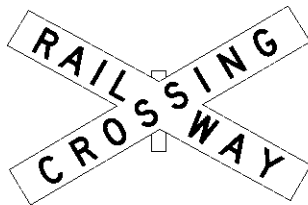

**Rule 121**

---

**121 Stopping and giving way at a stop sign at a level crossing**

A driver at a level crossing with a *stop sign* must:

- (a) stop at the stop line or, if there is no stop line, at the *stop sign*; and
- (b) give way to any train or tram on, approaching or entering the crossing.

Offence provision.

*Note 1* *Approaching, enter, stop line* and *tram* are defined in the dictionary.

*Note 2* For this rule, *give way* means the driver must remain stationary until it is safe for the driver to proceed — see the definition in the dictionary.

Stop sign

**122 Giving way at a give way sign or give way line at a level crossing**

A driver at a level crossing with a *give way sign* or give way line must give way to any train or tram on, approaching or entering the crossing.

Offence provision.

*Note 1* *Approaching, enter, give way line* and *tram* are defined in the dictionary.

*Note 2* For this rule, *give way* means the driver must slow down and, if necessary, stop to avoid a collision — see the definition in the dictionary.

Give way sign

**123 Entering a level crossing when a train or tram is approaching etc**

A driver must not enter a level crossing if:

- (a) warning lights (for example, twin red lights or rotating red lights) are operating or warning bells are ringing; or
- (b) a gate, boom or barrier at the crossing is closed or is opening or closing; or
- (c) a train or tram is on or entering the crossing; or

**Rule 124**

- (d) a train or tram approaching the crossing can be seen from the crossing, or is sounding a warning, and there would be a danger of a collision with the train or tram if the driver entered the crossing; or
- (e) the driver cannot drive through the crossing because the crossing, or a road beyond the crossing, is blocked.

Offence provision.

*Examples for paragraph (e)*

The crossing, or a road beyond the crossing, may be blocked by congested traffic, a disabled vehicle, a collision between vehicles or between a vehicle and a pedestrian, or by stock on the road.

*Note* **Approaching**, **enter**, **tram** and **twin red lights** are defined in the dictionary.

**124 Leaving a level crossing**

A driver who enters a level crossing must leave the level crossing as soon as the driver can do so safely.

Offence provision.

*Note* **Enter** is defined in the dictionary.

***THIS PAGE INTENTIONALLY LEFT BLANK***



## Part 11 Keeping left, overtaking and other driving rules

### Division 1 General

#### 125 Unreasonably obstructing drivers or pedestrians

- (1) A driver must not unreasonably obstruct the path of another driver or a pedestrian.

Offence provision.

*Note* **Driver** includes a person in control of a vehicle — see the definition of *drive* in the dictionary.

- (2) For this rule, a driver does not unreasonably obstruct the path of another driver or a pedestrian only because:
- (a) the driver is stopped in traffic; or
  - (b) the driver is driving more slowly than other vehicles (unless the driver is driving abnormally slowly in the circumstances).

*Example of a driver driving abnormally slowly*

A driver driving at a speed of 20 kilometres per hour on a length of road to which a speed-limit of 80 kilometres per hour applies when there is no reason for the driver to drive at that speed on the length of road.

#### 126 Keeping a safe distance behind vehicles

A driver must drive a sufficient distance behind a vehicle travelling in front of the driver so the driver can, if necessary, stop safely to avoid a collision with the vehicle.

Offence provision.

#### 127 Keeping a minimum distance between long vehicles

- (1) The driver of a long vehicle must drive at least the required minimum distance behind another long vehicle travelling in front of the driver, unless the driver is:
- (a) driving on a multi-lane road or any length of road in a built-up area; or
  - (b) overtaking.

Offence provision.

*Note* **Built-up area**, **length** of road, **multi-lane road** and **overtake** are defined in the dictionary.

- (2) In this rule:

**long vehicle** means a vehicle that, together with any load or projection, is 7.5 metres long, or longer.

*Note* **Vehicle** includes a combination — see rule 15 (d).

**required minimum distance** means:

- (a) for a long vehicle in a road train area — 200 metres or, if another law of this jurisdiction provides another distance for the area, that distance; or
- (b) for a long vehicle in another area — 60 metres or, if another law of this jurisdiction provides another distance for the area, that distance.

**Rule 128**

---

**road train** means a combination that is a road train for the *Australian Road Rules* under another law of this jurisdiction.

*Note* **Combination** is defined in the dictionary.

**road train area** means an area where, under another law of this jurisdiction, road trains may be driven.

**128 Entering blocked intersections**

A driver must not enter an intersection if the driver cannot drive through the intersection because the intersection, or a road beyond the intersection, is blocked.

Offence provision.

*Examples*

The intersection, or a road beyond the intersection, may be blocked by congested traffic, a disabled vehicle, a collision between vehicles or between a vehicle and a pedestrian, or by a fallen load on the road.

*Note* **Enter** and **intersection** are defined in the dictionary.

## Division 2 Keeping to the left

### 129 Keeping to the far left side of a road

- (1) A driver on a road (except a multi-lane road or a road with 2 or more lines of traffic travelling in the same direction as the driver) must drive as near as practicable to the far left side of the road.

Offence provision.

*Note* **Multi-lane road** is defined in the dictionary.

- (2) This rule does not apply to the rider of a motor bike.

*Note* **Motor bike** is defined in the dictionary.

- (3) In this rule:

**road** does not include a road-related area.

*Note* **Road-related area** includes the shoulder of a road — see rule 13.

### 130 Keeping to the left on a multi-lane road

- (1) This rule applies to a driver driving on a multi-lane road if:
- (a) the speed-limit applying to the driver for the length of road where the driver is driving is over 80 kilometres per hour; or
  - (b) a *keep left unless overtaking sign* applies to the length of road where the driver is driving.

*Note 1* **Length** of road and **multi-lane road** are defined in the dictionary.

*Note 2* Part 3 deals with speed-limits.

- (2) The driver must not drive in the right lane unless:

- (a) the driver is turning right, or making a U-turn from the centre of the road, and is giving a right change of direction signal; or
- (b) the driver is overtaking; or
- (c) a *left lane must turn left sign* or left traffic lane arrows apply to any other lane and the driver is not turning left; or
- (d) the driver is required to drive in the right lane under rule 159; or
- (e) the driver is avoiding an obstruction; or
- (f) the traffic in each other lane is congested; or
- (g) the traffic in every lane is congested.

Offence provision.

*Note 1* **Centre of the road**, **left traffic lane arrows**, **obstruction**, **overtake**, **right change of direction signal**, **traffic** and **U-turn** are defined in the dictionary.

*Note 2* Rule 159 deals with traffic signs that require a particular kind of vehicle to drive in the marked lane indicated by the signs.

*Note 3* Rule 329 deals with when a traffic control device applies to a marked lane.

- (3) A *keep left unless overtaking sign* on a multi-lane road applies to the length of road beginning at the sign and ending at the nearest of the following:
- (a) an *end keep left unless overtaking sign* on the road;

**Rule 131**

- (b) a traffic sign or road marking on the road that indicates that the road is no longer a multi-lane road;
- (c) if the road ends at a T-intersection or dead end — the end of the road.

*Note* **Road marking**, **T-intersection** and **traffic sign** are defined in the dictionary.

(4) In this rule:

**lane**, for a driver, means a marked lane for vehicles travelling in the same direction as the driver, but does not include a special purpose lane in which the driver is not permitted to drive.

*Note 1* **Marked lane** and **special purpose lane** are defined in the dictionary.

*Note 2* Rule 95 deals with driving in emergency stopping lanes, and Division 6 of this Part deals with driving in other special purpose lanes.

Keep left unless overtaking sign



End keep left unless overtaking sign



**131 Keeping to the left of oncoming vehicles**

A driver must drive to the left of any oncoming vehicle unless:

- (a) the driver is turning right at an intersection; and
- (b) the driver is passing an oncoming vehicle turning right at the intersection; and
- (c) there is no traffic sign or road marking indicating that the driver must pass to the left of the oncoming vehicle.

Offence provision.

*Note 1* **Intersection**, **oncoming vehicle**, **road marking** and **traffic sign** are defined in the dictionary.

*Note 2* Part 4, Division 2 deals with making right turns.

*Examples*

Example 1  
Driving to the left of an oncoming vehicle

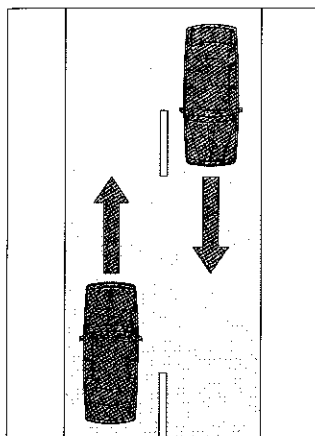

Example 2  
Oncoming vehicles turning right passing to the right of each other

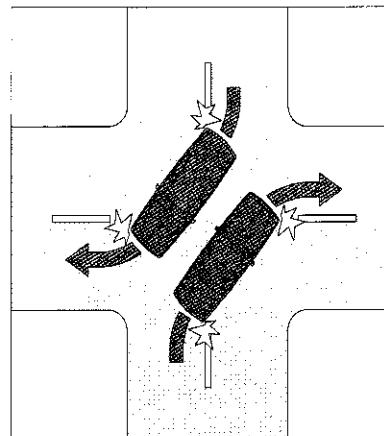

**132 Keeping to the left of the centre of a road or the dividing line**

- (1) A driver on a two-way road without a dividing line or median strip must drive to the left of the centre of the road, except as permitted under rule 133 or 139 (1).

Offence provision.

*Note 1* *Centre of the road, dividing line, median strip* and *two-way road* are defined in the dictionary.

*Note 2* For the meaning of driving to the *left* of something, see rule 351 (3).

*Note 3* Rule 133 deals with driving to the right of the centre of the road to overtake another vehicle, to enter or leave a road, to move from one part of the road to another, or because of the width or condition of the road. Rule 139 (1) deals with driving to the right of the centre of the road to avoid an obstruction.

- (2) A driver on a road with a dividing line must drive to the left of the dividing line, except as permitted under rule 134 or 139 (2).

Offence provision.

*Note* Rule 134 deals with driving to the right of the dividing line to overtake another vehicle, to enter or leave a road, or to move from one part of the road to another. Rule 139 (2) deals with driving to the right of the dividing line to avoid an obstruction.

- (3) This rule, and rules 133, 134 and 139 (1) and (2), apply to a service road to which a *two-way sign* applies as if it were a separate road, but do not apply to any other service road.

*Note 1* *Service road* is defined in the dictionary.

*Note 2* Rule 136 deals with driving on a service road without a *two-way sign*.

Two-way sign

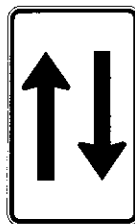

*Note for diagram* There is another permitted version of the *two-way sign* — see the diagram in Schedule 3.

*Examples for subrule (2)*

**Example 1**  
Driving to the left of a single continuous  
dividing line only

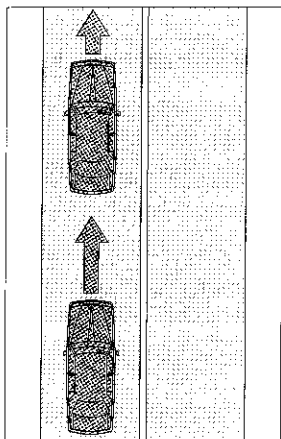

**Example 2**  
Driving to the left of a single continuous  
dividing line to the left of a broken dividing line

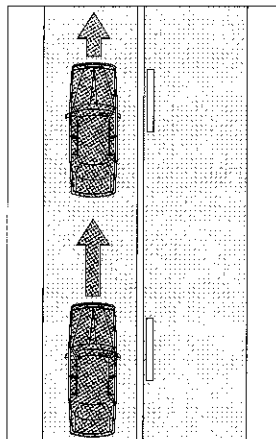

**Example 3**  
Driving to the left of 2 parallel continuous dividing lines

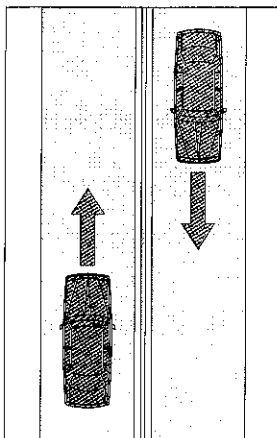

**133 Exceptions to keeping to the left of the centre of a road**

- (1) This rule applies to a driver on a two-way road without a dividing line or median strip.

*Note* **Dividing line**, **median strip** and **two-way road** are defined in the dictionary.

- (2) The driver may drive to the right of the centre of the road:

- (a) to overtake another driver; or
- (b) to enter or leave the road; or
- (c) to enter a part of the road of one kind from a part of the road of another kind (for example, moving to or from a service road or emergency stopping lane).

*Note* **Centre of the road**, **overtake** and **service road** are defined in the dictionary, and **emergency stopping lane** is defined in rule 95.

- (3) The driver may also drive to the right of the centre of the road if:
  - (a) because of the width or condition of the road, it is not practicable to drive to the left of the centre of the road; and
  - (b) the driver can do so safely.

### 134 Exceptions to keeping to the left of a dividing line

- (1) This rule applies to a driver on a road with a dividing line.

*Note* **Dividing line** is defined in the dictionary.

- (2) If the dividing line is a broken dividing line only, or a broken dividing line to the left of a single continuous dividing line, the driver may drive to the right of the dividing line to overtake another driver.

*Note 1* **Overtake** is defined in the dictionary.

*Note 2* A driver must not overtake another driver unless the driver has a clear view of any approaching traffic, and it is safe to overtake the other driver — see rule 140.

- (3) If the dividing line is not 2 parallel continuous dividing lines, the driver may drive to the right of the dividing line:
  - (a) to enter or leave the road; or
  - (b) to enter a part of the road of one kind from a part of the road of another kind (for example, moving to or from a service road or emergency stopping lane).

*Note* **Emergency stopping lane** is defined in rule 95, and **service road** is defined in the dictionary.

*Examples*

Example 1

Driving to the right of the centre of the road permitted — overtaking on a road with a broken dividing line only

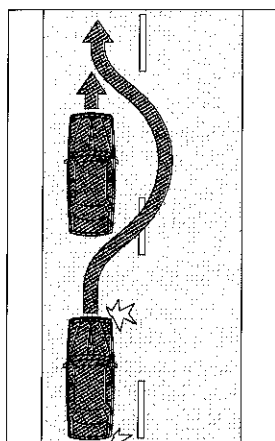

Example 2

Driving to the right of the centre of the road permitted — overtaking on a road with a broken dividing line to the left of a single continuous dividing line

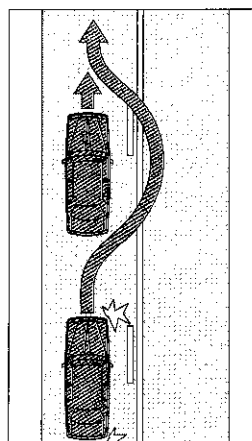

**Rule 135**

Example 3

Driving to the right of the centre of the road **not** permitted — overtaking on a road with a single continuous dividing line only

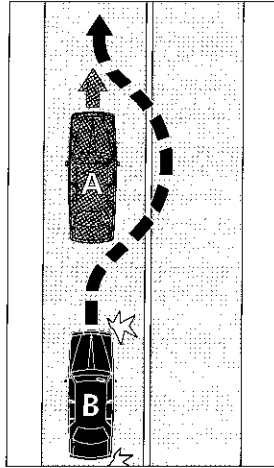

Example 4

Driving to the right of the centre of the road **not** permitted — overtaking on a road with a single continuous dividing line to the left of a broken dividing line

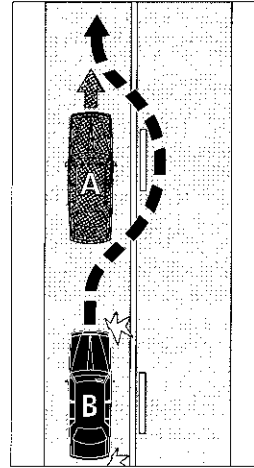

Example 5

Driving to the right of the centre of the road **not** permitted — overtaking on a road with 2 parallel continuous dividing lines

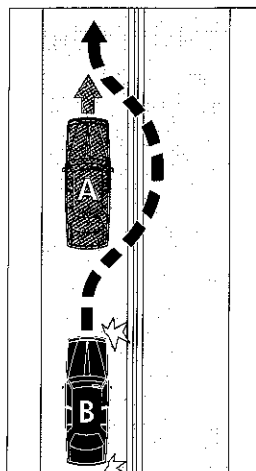

**135 Keeping to the left of a median strip**

- (1) A driver on a road with a median strip must drive to the left of the median strip, unless the driver is:
  - (a) entering or driving in a median strip parking area; or
  - (b) required to drive to the right of the median strip by a *keep right sign*.

Offence provision.

*Note 1* **Median strip** and **median strip parking area** are defined in the dictionary.

*Note 2* For the meaning of driving to the **left** of something, see rule 351 (3).



(2) In this rule:

**median strip** does not include a painted island.

*Note 1* **Painted island** is defined in the dictionary.

*Note 2* Rule 138 deals with keeping off painted islands.

Keep right sign



### 136 Driving on a one-way service road

A driver on the part of the road that is a service road (except a service road to which a *two-way sign* applies) must drive in the same direction as a vehicle travelling on the part of the road used by the main body of moving vehicles in the marked lane or line of traffic closest to the service road.

Offence provision.

*Note* **Marked lane**, **part of the road used by the main body of moving vehicles** and **service road** are defined in the dictionary.

Two-way sign

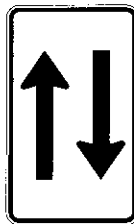

*Note for diagram* There is another permitted version of the *two-way sign* — see the diagram in Schedule 3.

### 137 Keeping off a dividing strip

(1) A driver must not drive on a dividing strip, except as permitted under this rule or rule 139 (4).

Offence provision.

*Note 1* **Dividing strip** is defined in the dictionary.

*Note 2* Rule 139 deals with avoiding obstructions on a road.

**Rule 138**

- (2) A driver may drive on a dividing strip that is at the same level as the road, and marked at each side by a continuous line:
- (a) to enter or leave the road; or
  - (b) to enter or leave an area on the dividing strip to which a parking control sign applies if the driver is permitted to park in the area.

*Note 1* **Parking control sign** is defined in the dictionary.

*Note 2* Part 12 deals with restrictions on stopping and parking.

- (3) In this rule:

**dividing strip** does not include a painted island.

*Note 1* **Painted island** is defined in the dictionary.

*Note 2* Rule 138 deals with keeping off painted islands.

**138 Keeping off a painted island**

- (1) A driver must not drive on or over a single continuous line, or 2 parallel continuous lines, along a side of or surrounding a painted island, except as permitted under this rule or rule 139 (4).

Offence provision.

*Note 1* **Painted island** is defined in the dictionary.

*Note 2* Rule 139 deals with avoiding obstructions on a road.

*Example*

Painted island surrounded by 2 parallel continuous lines

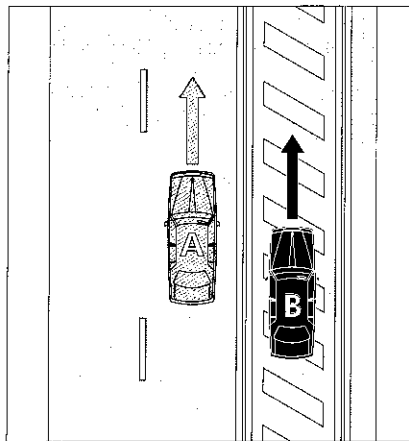

In this example, vehicle B is contravening the rule.

- (2) A driver may drive on or over a single continuous line along the side of or surrounding a painted island:
- (a) to enter or leave the road; or
  - (b) to enter a turning lane that begins immediately after the painted island.

*Note 1* **Turning lane** is defined in the dictionary.

*Note 2* Rule 85 deals with the give way rules applying to a driver entering a turning lane from a painted island.

### 139 Exceptions for avoiding obstructions on a road

- (1) A driver on a two-way road without a dividing line or median strip may drive to the right of the centre of the road to avoid an obstruction if:
  - (a) the driver has a clear view of any approaching traffic; and
  - (b) it is necessary and reasonable, in all the circumstances, for the driver to drive to the right of the centre of the road to avoid the obstruction; and
  - (c) the driver can do so safely.

*Note* **Approaching, centre of the road, dividing line, median strip, obstruction, traffic** and **two-way road** are defined in the dictionary.

- (2) A driver on a road with a dividing line may drive to the right of the dividing line to avoid an obstruction if:
  - (a) the driver has a clear view of any approaching traffic; and
  - (b) it is necessary and reasonable, in all the circumstances, for the driver to drive to the right of the dividing line to avoid the obstruction; and
  - (c) the driver can do so safely.
- (3) For subrule (2), if the dividing line is a single continuous dividing line to the left of a broken dividing line, a single continuous dividing line only or 2 parallel continuous dividing lines, the hazard in driving to the right of such a dividing line must be taken into account in deciding whether it is reasonable to drive to the right of the dividing line.
- (4) A driver may drive on a dividing strip, or on or over a single continuous line, or 2 parallel continuous lines, along a side of or surrounding a painted island, to avoid an obstruction if:
  - (a) the driver has a clear view of any approaching traffic; and
  - (b) it is necessary and reasonable to drive on the dividing strip or painted island to avoid the obstruction; and
  - (c) the driver can do so safely.

*Note* **Dividing strip** and **painted island** are defined in the dictionary.

## Division 3 Overtaking

### 140 No overtaking unless safe to do so

A driver must not overtake a vehicle unless:

- (a) the driver has a clear view of any approaching traffic; and
- (b) the driver can safely overtake the vehicle.

Offence provision.

*Note 1* **Approaching, overtake** and **traffic** are defined in the dictionary.

*Note 2* A driver is not permitted to overtake another vehicle by crossing a single continuous dividing line only, a single continuous dividing line to the left of a broken dividing line or 2 parallel continuous dividing lines — see rules 134 (2) and 132 (2).

### 141 No overtaking etc to the left of a vehicle

- (1) A driver (except the rider of a bicycle) must not overtake a vehicle to the left of the vehicle unless:

- (a) the driver is driving on a multi-lane road and the vehicle can be safely overtaken in a marked lane to the left of the vehicle; or
- (b) the vehicle is turning right, or making a U-turn from the centre of the road, and is giving a right change of direction signal.

Offence provision.

*Note* **Bicycle, centre of the road, marked lane, multi-lane road, overtake, right change of direction signal** and **U-turn** are defined in the dictionary.

- (2) The rider of a bicycle must not ride past, or overtake, to the left of a vehicle that is turning left and is giving a left change of direction signal.

Offence provision.

*Note* **Left change of direction signal** is defined in the dictionary.

- (3) In this rule:

**turning right** does not include making a hook turn.

**vehicle** does not include a tram, a bus travelling along tram tracks, or any vehicle displaying a *do not overtake turning vehicle sign*.

*Note 1* **Bus, tram** and **travelling along tram tracks** are defined in the dictionary.

*Note 2* Part 4, Division 3 deals with making hook turns.

*Note 3* Division 7 of this Part deals with overtaking and passing trams (and buses travelling along tram tracks). Rule 143 deals with overtaking or passing a vehicle displaying a *do not overtake turning vehicle sign*.

**142 No overtaking to the right of a vehicle turning right etc**

- (1) A driver must not overtake to the right of a vehicle if the vehicle is turning right, or making a U-turn from the centre of the road, and is giving a right change of direction signal.

Offence provision.

*Note* *Centre of the road*, *overtake*, *right change of direction signal* and *U-turn* are defined in the dictionary.

- (2) In this rule:

*turning right* does not include making a hook turn.

*vehicle* does not include a tram, a bus travelling along tram tracks, or any vehicle displaying a *do not overtake turning vehicle sign*.

*Note 1* *Bus*, *tram* and *travelling along tram tracks* are defined in the dictionary.

*Note 2* Part 4, Division 3 deals with making hook turns.

*Note 3* Division 7 of this Part deals with overtaking and passing trams (and buses travelling along tram tracks). Rule 143 deals with overtaking or passing a vehicle displaying a *do not overtake turning vehicle sign*.

**143 Passing or overtaking a vehicle displaying a do not overtake turning vehicle sign**

- (1) A driver must not drive past, or overtake, to the left of a vehicle displaying a *do not overtake turning vehicle sign* if the vehicle is turning left and is giving a left change of direction signal, unless it is safe to do so.

Offence provision.

*Note* *Left change of direction signal* and *overtake* are defined in the dictionary.

- (2) A driver must not drive past, or overtake, to the right of a vehicle displaying a *do not overtake turning vehicle sign* if the vehicle is turning right, or making a U-turn from the centre of the road, and is giving a right change of direction signal, unless it is safe to do so.

Offence provision.

*Example*

A driver driving on a multi-lane road who is turning right at an intersection to which a *right turn only sign* applies may drive past a vehicle displaying a *do not overtake turning vehicle sign* that is turning right from another marked lane, and giving a right change of direction signal, if it is safe to do so.

*Note* *Centre of the road*, *right change of direction signal* and *U-turn* are defined in the dictionary.

**Rule 144**

---

(3) In this rule:

*turning right* does not include making a hook turn.

*Note* Part 4, Division 3 deals with making hook turns.

Do not overtake turning vehicle signs



*Note for diagrams* These signs are displayed on certain long vehicles.

#### 144 Keeping a safe distance when overtaking

A driver overtaking a vehicle:

- (a) must pass the vehicle at a sufficient distance to avoid a collision with the vehicle or obstructing the path of the vehicle; and
- (b) must not return to the marked lane or line of traffic where the vehicle is travelling until the driver is a sufficient distance past the vehicle to avoid a collision with the vehicle or obstructing the path of the vehicle.

Offence provision.

*Note* *Marked lane* and *overtake* are defined in the dictionary.

#### 145 Driver being overtaken not to increase speed

If a driver is overtaking another driver on a two-way road by crossing a dividing line, or crossing to the right of the centre of the road, the other driver must not increase the speed at which the driver is driving until the first driver:

- (a) has passed the other driver; and
- (b) has returned to the marked lane or line of traffic where the other driver is driving; and
- (c) is a sufficient distance in front of the other driver to avoid a collision.

Offence provision.

*Note* *Centre of the road*, *dividing line*, *marked lane*, *overtake* and *two-way road* are defined in the dictionary.

## **Division 4      Driving in marked lanes or lines of traffic**

### **146 Driving within a single marked lane or line of traffic**

- (1) A driver on a multi-lane road must drive so the driver's vehicle is completely in a marked lane, unless the driver is:
- (a) entering a part of the road of one kind from a part of the road of another kind (for example, moving to or from a service road, a shoulder of the road or emergency stopping lane); or
  - (b) entering or leaving the road; or
  - (c) moving from one marked lane to another marked lane; or
  - (d) avoiding an obstruction; or
  - (e) obeying a traffic control device applying to the marked lane; or
  - (f) permitted to drive in more than one marked lane under another provision of the *Australian Road Rules* or under another law of this jurisdiction.

Offence provision.

*Note 1* **Driver's vehicle, marked lane, multi-lane road, obstruction, service road and traffic control device** are defined in the dictionary, **shoulder** is defined in rule 12, and **emergency stopping lane** is defined in rule 95.

*Note 2* A driver is generally not permitted to move from one marked lane to another marked lane across a continuous line separating the lanes — see rule 147.

*Note 3* Rule 148 deals with giving way when moving from one marked lane to another marked lane.

*Note 4* An overhead lane control device may require a driver to leave a marked lane — see rule 152.

*Note 5* Drivers of certain long vehicles are permitted to use 2 marked lanes when turning at an intersection — see rule 28 (left turns) and rule 32 (right turns).

- (2) A driver on a road with 2 or more lines of traffic travelling in the same direction as the driver, but without marked lanes, must drive so the driver's vehicle is completely in a single line of traffic unless:
- (a) it is not practicable to drive completely in a single line of traffic; or
  - (b) the driver is entering a part of the road of one kind from a part of the road of another kind (for example, moving to or from a service road, a shoulder of the road or an emergency stopping lane); or
  - (c) the driver is entering or leaving the road; or
  - (d) the driver is moving from one line of traffic to another line of traffic; or
  - (e) the driver is avoiding an obstruction.

Offence provision.

*Note* Rule 148 deals with giving way when moving from one line of traffic to another line of traffic.

### **147 Moving from one marked lane to another marked lane across a continuous line separating the lanes**

A driver on a multi-lane road must not move from one marked lane to another marked lane by crossing a continuous line separating the lanes unless:

- (a) the driver is avoiding an obstruction; or
- (b) the driver is obeying a traffic control device applying to the first marked lane; or

- (c) the driver is permitted to drive in both marked lanes under another provision of the *Australian Road Rules* or under another law of this jurisdiction; or
- (d) either of the marked lanes is a special purpose lane in which the driver is permitted to drive under the *Australian Road Rules* and the driver is moving to or from the special purpose lane.

Offence provision.

*Note 1* **Marked lane**, **multi-lane road**, **obstruction**, **special purpose lane** and **traffic control device** are defined in the dictionary.

*Note 2* An overhead lane control device may require a driver to leave a marked lane — see rule 152.

*Note 3* Drivers of certain long vehicles are permitted to use 2 marked lanes when turning at an intersection — see rule 28 (left turns) and rule 32 (right turns).

*Note 4* Rule 95 deals with driving in emergency stopping lanes, and Division 6 of this Part deals with driving in other special purpose lanes.

#### **148 Giving way when moving from one marked lane or line of traffic to another marked lane or line of traffic**

- (1) A driver on a multi-lane road who is moving from one marked lane (whether or not the lane is ending) to another marked lane must give way to any vehicle travelling in the same direction as the driver in the marked lane to which the driver is moving.

Offence provision.

*Note 1* **Marked lane** and **multi-lane road** are defined in the dictionary.

*Note 2* For this rule, **give way** means the driver must slow down and, if necessary, stop to avoid a collision — see the definition in the dictionary.

*Example*

Giving way when moving from one marked lane to another marked lane

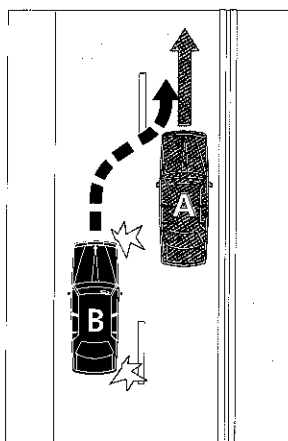

In this example, vehicle B must give way to vehicle A.

- (2) A driver on a road with 2 or more lines of traffic travelling in the same direction as the driver, and who is moving from one line of traffic (whether or not the line of traffic is ending) to another line of traffic, must give way to any vehicle travelling in the same direction as the driver in the line of traffic to which the driver is moving.

Offence provision.



- (3) Subrule (2) does not apply to a driver if the line of traffic in which the driver is driving is merging with the line of traffic to which the driver is moving.

*Note* Rule 149 deals with giving way when lines of traffic merge.

*Example*

Giving way when moving from one line of traffic to another line of traffic when the lines are not merging

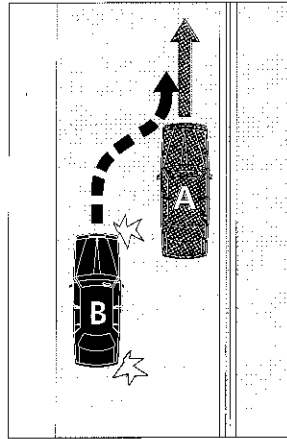

In this example, vehicle B must give way to vehicle A

#### **149 Giving way when lines of traffic merge into a single line of traffic**

A driver in a line of traffic that is merging with one or more lines of traffic travelling in the same direction as the driver must give way to a vehicle in another line of traffic if any part of the vehicle is ahead of the driver's vehicle.

Offence provision.

*Note 1* *Driver's vehicle* is defined in the dictionary.

*Note 2* For this rule, *give way* means the driver must slow down and, if necessary, stop to avoid a collision — see the definition in the dictionary.

*Example*

Giving way when lines of traffic merge into a single line of traffic

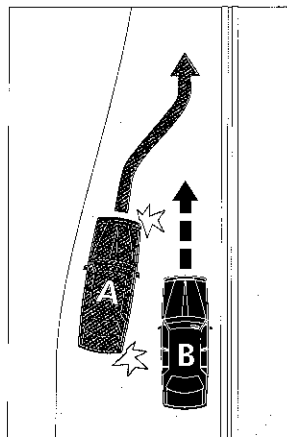

In this example, vehicle B must give way to vehicle A.

**Rule 150**

---

**150 Driving on or across a continuous white edge line**

- (1) A driver must not drive on or over a continuous white edge line on a road unless the driver is:
- (a) turning at an intersection; or
  - (b) entering or leaving the road; or
  - (c) entering a part of the road of one kind from a part of the road of another kind (for example, moving to or from a service road, a shoulder of the road or an emergency stopping lane); or
  - (d) overtaking a vehicle that is turning right, or making a U-turn from the centre of the road, and is giving a right change of direction signal; or
  - (e) driving a slow-moving vehicle; or
  - (f) stopping at the side of the road (including any shoulder of the road); or
  - (g) driving a vehicle that is too wide, or too long, to drive on the road without driving on or over the edge line; or
  - (h) permitted to drive on or over the edge line under another law of this jurisdiction.

Offence provision.

*Note 1* *Centre of the road, edge line, intersection, overtake, right change of direction signal, service road* and *U-turn* are defined in the dictionary, *emergency stopping lane* is defined in rule 95, and *shoulder* is defined in rule 12.

*Note 2* A driver must not stop at the side of a road marked with a continuous yellow edge line — see rule 169.

- (2) This rule does not apply to the rider of a bicycle or animal.

*Note* *Bicycle* is defined in the dictionary.

**151 Riding a motor bike or bicycle alongside more than 1 other rider**

- (1) The rider of a motor bike or bicycle must not ride on a road that is not a multi-lane road alongside more than 1 other rider, unless subrule (3) applies to the rider.

Offence provision.

*Note* *Bicycle, motor bike* and *multi-lane road* are defined in the dictionary, and *rider* is defined in rule 17.

- (2) The rider of a motor bike or bicycle must not ride in a marked lane alongside more than 1 other rider in the marked lane, unless subrule (3) applies to the rider.

Offence provision.

*Note* *Marked lane* is defined in the dictionary.

- (3) The rider of a motor bike or bicycle may ride alongside more than 1 other rider if the rider is:
- (a) overtaking the other riders; or
  - (b) permitted to do so under another law of this jurisdiction.

*Note* *Overtake* is defined in the dictionary.

- (4) If the rider of a motor bike or bicycle is riding on a road that is not a multi-lane road alongside another rider, or in a marked lane alongside another rider in the marked lane, the rider must ride not over 1.5 metres from the other rider.

Offence provision.

(5) In this rule:

**road** does not include a road-related area, but includes a bicycle path, shared path and any shoulder of the road.

*Note* **Bicycle path** is defined in rule 239, **road-related area** is defined in rule 13, **shared path** is defined in rule 242, and **shoulder** is defined in rule 12.

## Division 5 Obeying overhead lane control devices applying to marked lanes

### 152 Complying with overhead lane control devices

- (1) A driver in a marked lane to which an overhead lane control device applies must comply with this rule.

Offence provision.

*Note* **Marked lane** and **overhead lane control device** are defined in the dictionary.

- (2) If the device displays an illuminated red diagonal cross or is a traffic sign displaying a red diagonal cross, the driver must not drive in the marked lane past the device.
- (3) If the device displays a flashing illuminated red diagonal cross, the driver must leave the marked lane as soon as it is safe to do so.
- (4) If the device displays an illuminated white, green or yellow arrow pointing downwards or indicating one or more directions, the driver may drive in the marked lane past the device.

*Example*

Overhead lane control device applying to marked lanes

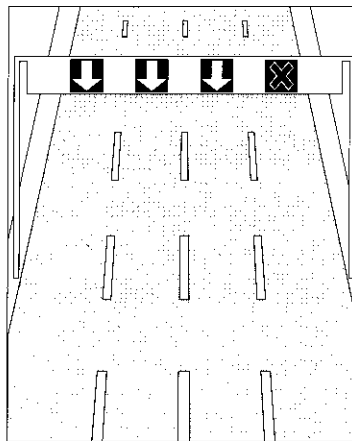

*Note for diagram* If the device displays an arrow indicating one or more directions, the device operates also as traffic lane arrows — see the definition of **traffic lane arrows** in the dictionary. Rule 92 deals with traffic lane arrows.

## Division 6 Driving in marked lanes designated for special purposes

### 153 Bicycle lanes

- (1) A driver (except the rider of a bicycle) must not drive in a bicycle lane, unless the driver is permitted to drive in the bicycle lane under this rule or rule 158.

Offence provision.

*Note 1* **Bicycle** is defined in the dictionary.

*Note 2* Rule 158 provides additional exceptions applying to this rule, and also provides a defence to the prosecution of a driver for an offence against this rule.

- (2) If stopping or parking is permitted at a place in a bicycle lane under another law of this jurisdiction, a driver may drive for up to 50 metres in the bicycle lane to stop or park at that place.

*Note* Part 12 deals with parking and restricted stopping areas.

- (3) A driver may drive for up to 50 metres in a bicycle lane if:

- (a) the driver is driving a public bus, public minibus or taxi, and is dropping off or picking up, passengers; and
- (b) there is not another law of this jurisdiction prohibiting the driver from driving in the bicycle lane.

*Note* **Public bus**, **public minibus** and **taxi** are defined in the dictionary.

- (4) A **bicycle lane** is a marked lane, or the part of a marked lane:

- (a) beginning at a *bicycle lane sign* applying to the lane; and
- (b) ending at the nearest of the following:
  - (i) an *end bicycle lane sign* applying to the lane;
  - (ii) an intersection (unless the lane is at the unbroken side of the continuing road at a T-intersection or continued across the intersection by broken lines);
  - (iii) if the road ends at a dead end — the end of the road.

*Note* **Continuing road**, **intersection**, **marked lane** and **T-intersection** are defined in the dictionary.

Bicycle lane sign



End bicycle lane sign



*Note for diagrams* There are a number of other permitted versions of the *bicycle lane sign*, and another permitted version of the *end bicycle lane sign* — see the diagrams in Schedule 3.

### 154 Bus lanes

- (1) A driver (except the driver of a public bus) must not drive in a bus lane, unless the driver is permitted to drive in the bus lane under rule 158.

Offence provision.

*Note 1* **Public bus** is defined in the dictionary.

*Note 2* Rule 158 provides additional exceptions applying to this rule, and also provides a defence to the prosecution of a driver for an offence against this rule.

- (2) A **bus lane** is a marked lane, or the part of a marked lane:
- (a) beginning at a *bus lane sign*; and
  - (b) ending at an *end bus lane sign*.

*Note* **Marked lane** is defined in the dictionary.

Bus lane sign



End bus lane sign



*Note for diagrams* There are a number of other permitted versions of each of these signs — see the diagrams in Schedule 3.

### 155 Tram lanes

- (1) A driver (except the driver of a tram or public bus) must not drive in a tram lane, unless the driver is permitted to drive in the tram lane under this rule or rule 158.

Offence provision.

*Note 1* **Public bus** and **tram** are defined in the dictionary.

*Note 2* Rule 158 provides additional exceptions applying to this rule, and also provides a defence to the prosecution of a driver for an offence against this rule.

- (2) A driver may drive in a tram lane if the driver is driving a truck and it is necessary for the driver to drive in the tram lane to reach a place to drop off, or pick up, passengers or goods.

- (3) A *tram lane* is a part of a road with tram tracks that:
- (a) is marked along the left side of the tracks by a continuous yellow line parallel to the tracks; and
  - (b) begins at a *tram lane sign*; and
  - (c) ends at an *end tram lane sign*.

*Note* *Tram tracks* and *left* are defined in the dictionary.

Tram lane sign



End tram lane sign



*Note for diagrams* There are a number of other permitted versions of the *tram lane sign* and another permitted version of the *end tram lane sign* — see the diagrams in Schedule 3.

*Example*

Tram lane

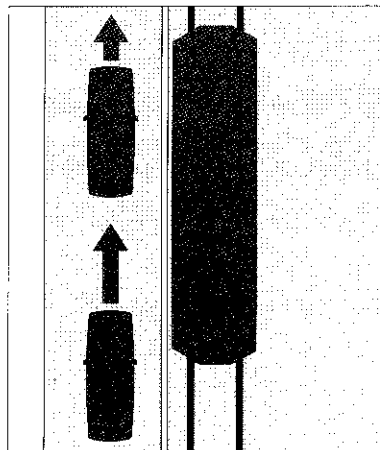

## 156 Transit lanes

- (1) A driver must not drive in a transit lane unless:
- (a) the driver is driving:
    - (i) a public bus, public minibus, motor bike, taxi or tram; or
    - (ii) if the *transit lane sign* applying to the transit lane is a *transit lane (T2) sign* — a vehicle carrying at least 1 other person; or
    - (iii) if the *transit lane sign* applying to the transit lane is a *transit lane (T3) sign* — a vehicle carrying at least 2 other people; or

(b) the driver is permitted to drive in the transit lane under rule 158.

Offence provision.

*Note 1* **Motor bike**, **public bus**, **public minibus**, **taxi** and **tram** are defined in the dictionary.

*Note 2* Rule 158 provides additional exceptions applying to this rule, and also provides a defence to the prosecution of a driver for an offence against this rule.

(2) A **transit lane** is a marked lane, or the part of a marked lane:

- (a) beginning at a *transit lane sign*; and
- (b) ending at an *end transit lane sign*.

*Note* **Marked lane** is defined in the dictionary.

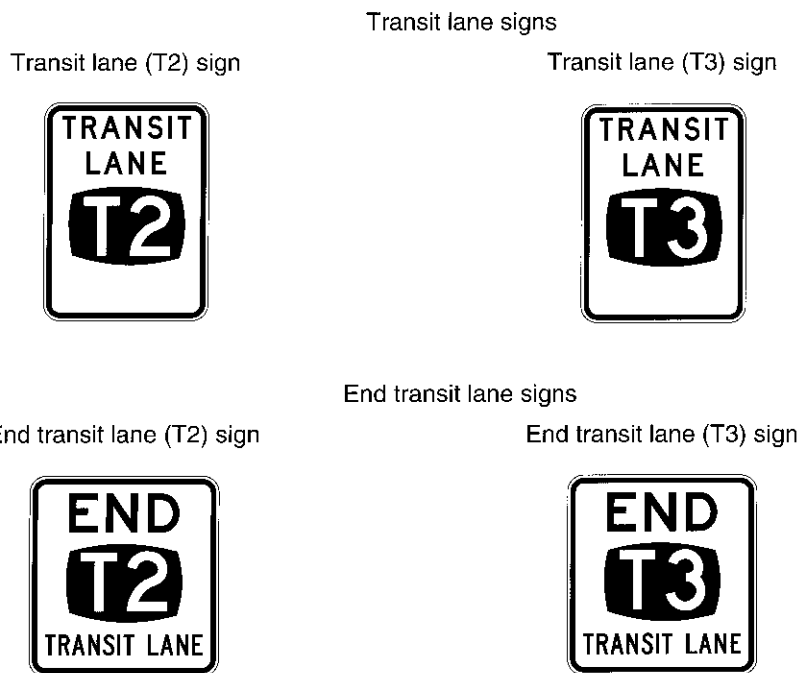

*Note for diagrams* There are a number of other permitted versions of the *transit lane sign* and another permitted version of the *end transit lane sign* — see the diagrams in Schedule 3.

## 157 Truck lanes

(1) A driver (except the driver of a truck) must not drive in a truck lane, unless the driver is permitted to drive in the truck lane under rule 158.

Offence provision.

*Note 1* **Truck** is defined in the dictionary.

*Note 2* Rule 158 provides additional exceptions applying to this rule, and also provides a defence to the prosecution of a driver for an offence against this rule.



- (2) A **truck lane** is a marked lane, or the part of a marked lane:
- (a) beginning at a *truck lane sign*; and
  - (b) ending at an *end truck lane sign*.

*Note* **Marked lane** is defined in the dictionary.

Truck lane sign



End truck lane sign



*Note for diagrams* There is another permitted version of the *end truck lane sign* — see the diagram in Schedule 3.

### 158 Exceptions to driving in special purpose lanes etc

- (1) The driver of any vehicle may drive for up to the permitted distance in a bicycle lane, bus lane, tram lane, transit lane or truck lane if it is necessary for the driver to drive in the lane:
- (a) to enter or leave the road; or
  - (b) to enter a part of the road of one kind from a part of the road of another kind (for example, moving to or from a service road, the shoulder of the road or an emergency stopping lane); or
  - (c) to overtake a vehicle that is turning right, or making a U-turn from the centre of the road, and is giving a right change of direction signal; or
  - (d) to enter a marked lane, or a line of traffic, from the side of the road.

*Note 1* **Permitted distance** is defined in subrule (4).

*Note 2* **Bicycle lane** is defined in rule 153, **bus lane** is defined in rule 154, **emergency stopping lane** is defined in rule 95, **centre of the road**, **marked lane**, **overtake**, **right change of direction signal**, **service road** and **U-turn** are defined in the dictionary, **shoulder** is defined in rule 12, **tram lane** is defined in rule 155, **transit lane** is defined in rule 156, and **truck lane** is defined in rule 157.

*Note 3* A driver must keep clear of a tram travelling in a tram lane — see rule 76.

- (2) The driver of any vehicle may drive in a bicycle lane, bus lane, tram lane, transit lane or truck lane if:
- (a) it is necessary for the driver to drive in the lane to avoid an obstruction; or
  - (b) information on or with a traffic sign applying to the lane indicates that the driver may drive in the lane; or
  - (c) the driver is permitted to drive in the lane under another law of this jurisdiction.

*Note* **Obstruction**, **traffic sign** and **with** are defined in the dictionary.

- (3) It is a defence to the prosecution of a driver for an offence against a provision of this Division for driving in a bicycle lane, bus lane, tram lane, transit lane or truck lane if:
- (a) it is necessary for the driver to drive in the lane to stop at a place in the lane; and

**Rule 159**

---

- (b) the driver is permitted to stop at that place under the *Australian Road Rules* or another law of this jurisdiction, or it is a defence under rule 165 for the driver to stop at that place; and
- (c) if the lane is a bicycle lane - the driver drives in the lane for no more than the permitted distance.

*Note* Rule 165 provides a defence to the prosecution of a driver for an offence against a provision of Part 12 (Restrictions on stopping and parking). The defence is available, for example, if the driver needs to stop to deal with a medical or other emergency.

- (4) In this rule:

*permitted distance* means:

- (a) for a bicycle lane — 50 metres; or
- (b) for any other lane — 100 metres.

**159 Marked lanes required to be used by particular kinds of vehicles**

- (1) If information on or with a traffic sign applying to a length of road indicates that a vehicle of a particular kind must drive in a particular marked lane, a driver driving a vehicle of that kind on the length of road must drive in the indicated lane, unless the driver is:
- (a) avoiding an obstruction; or
  - (b) obeying a traffic control device applying to the indicated lane; or
  - (c) permitted to drive in the indicated lane and also another marked lane under another provision of the *Australian Road Rules* or under another law of this jurisdiction.

Offence provision.

*Note 1* *Length* of road, *marked lane*, *obstruction*, *traffic control device*, *traffic sign* and *with* are defined in the dictionary.

*Note 2* An overhead lane control device may require a driver to leave a marked lane — see rule 152.

*Note 3* Drivers of certain long vehicles are permitted to use 2 marked lanes when turning at an intersection — see rule 28 (left turns) and rule 32 (right turns).

- (2) A traffic sign mentioned in this rule that is on a road applies to the length of road beginning at the sign and ending at the nearest of the following:
- (a) a traffic sign or road marking on the road that indicates that the first traffic sign no longer applies;
  - (b) the next intersection on the road;
  - (c) if the road ends at a T-intersection or dead end — the end of the road.

*Note 1* *Intersection*, *road marking*, *T-intersection* and *traffic sign* are defined in the dictionary.

*Note 2* Rule 322 (1) and (2) deal with the meaning of a traffic sign *on* a road.

*Examples of a traffic sign mentioned in the rule and a traffic sign indicating that the first traffic sign no longer applies*

Trucks use left lane sign

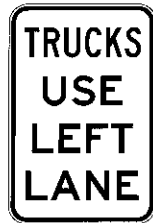

End trucks use left lane sign



*Note for diagrams* There is another permitted version of the *trucks use left lane sign* — see the diagrams in Schedule 3.

## **Division 7 Passing trams and safety zones**

*Note* **Bus**, **tram**, **tram tracks** and **travelling along tram tracks** are defined in the dictionary.

### **160 Passing or overtaking a tram that is not at or near the left side of a road**

- (1) This rule applies to a driver driving on a road with tram tracks that are not at or near the far left side of the road.
- (2) The driver must not drive past, or overtake, a tram to the right of the tram.

Offence provision.

*Note* **Overtake** is defined in the dictionary.

- (3) The driver must not drive past, or overtake, a tram if the tram is turning left or is giving a left change of direction signal, unless the driver is turning left and there is no danger of a collision with the tram.

Offence provision.

*Note* **Left change of direction signal** is defined in the dictionary.

- (4) In this rule:  
**tram** includes a bus travelling along tram tracks.

### **161 Passing or overtaking a tram at or near the left side of a road**

- (1) This rule applies to a driver driving on a road with tram tracks at or near the far left side of the road.
- (2) The driver must not drive past, or overtake, a tram to the left of the tram unless the driver is turning left and there is no danger of a collision with the tram.

Offence provision.

- (3) The driver must not drive past, or overtake, a tram if the tram is turning right or is giving a right change of direction signal.

Offence provision.

*Note* **Right change of direction signal** is defined in the dictionary.

- (4) In this rule:  
**tram** includes a bus travelling along tram tracks.

### **162 Driving past a safety zone**

- (1) A driver driving past a safety zone:
  - (a) must not drive on the safety zone; and
  - (b) must drive to the left of the safety zone at a speed that does not put at risk the safety of any pedestrian crossing the road to or from the safety zone.

Offence provision.

- (2) A **safety zone** is an area of a road:
- (a) at a place with *safety zone signs* at or near a tram stop; and
  - (b) indicated by a structure on the road (for example, a dividing strip, pedestrian refuge or traffic island).

*Note* **Dividing strip** and **traffic island** are defined in the dictionary.

Safety zone sign



### **163 Driving past the rear of a stopped tram**

- (1) A driver must comply with this rule if:
- (a) the driver is driving behind the rear of a tram travelling in the same direction as the driver; and
  - (b) the tram stops, except at the far left side of the road; and
  - (c) there is no safety zone, dividing strip or traffic island between the tram and the part of the road where the driver is driving.

Offence provision.

*Note* **Dividing strip** and **traffic island** are defined in the dictionary, and **safety zone** is defined in rule 162.

- (2) The driver must not drive past the rear of the tram if a pedestrian is crossing the road between the tram and the far left side of the road.
- (3) The driver may drive past the tram at a speed not over 10 kilometres per hour (or, if another law of this jurisdiction provides for another speed, not over the other speed) if there are no pedestrians crossing the road between the tram and the far left side of the road and:
- (a) if the driver is approaching or at traffic lights — the traffic lights are showing a green traffic light, or a green traffic arrow and the driver is turning in the direction indicated by the arrow; or
  - (b) the driver is directed to drive past the tram by an authorised person.

*Note 1* **Authorised person** is defined in the dictionary.

*Note 2* Part 6 deals with traffic lights.

- (4) In this rule:  
**tram** includes a bus travelling along tram tracks.

**Rule 164**

---

**164 Giving way to pedestrians crossing the road near a stopped tram**

- (1) A driver must comply with this rule if:
- (a) the driver is driving past, or overtaking, a tram travelling in the same direction as the driver; and
  - (b) the tram stops, except at the far left side of the road; and
  - (c) there is no safety zone, dividing strip or traffic island between the tram and the part of the road where the driver is driving.

Offence provision.

*Note* **Dividing strip**, **overtake** and **traffic island** are defined in the dictionary, and **safety zone** is defined in rule 162.

- (2) The driver must stop and give way to any pedestrian crossing the road between the tram and the far left side of the road.

*Note* For subrule (2), **give way** means remain stationary until it is safe to proceed — see the definition in the dictionary.

- (3) If the driver stops to give way to a pedestrian, the driver must not proceed until there is no pedestrian crossing the road between the tram and the far left side of the road.
- (4) If there is no pedestrian crossing the road between the tram and the far left side of the road, the driver may proceed to drive past, or overtake, the tram at a speed not over 10 kilometres per hour (or, if another law of this jurisdiction provides another speed, not over the other speed).
- (5) In this rule:  
**tram** includes a bus travelling along tram tracks.

## Part 12 Restrictions on stopping and parking

### Division 1 General

*Note 1* For the general rules about the application of traffic signs (including parking control signs), see Part 20, Divisions 2 and 3 especially rules 332 to 335 and 346. Parking control signs often include information about the times they apply and the types of vehicles to which they do not apply — see rules 317 and 318. For the meaning of abbreviations and symbols on parking control signs, see rule 347 and Schedule 1.

*Note 2* **Park** and **stop** are defined in the dictionary.

#### 165 Stopping in an emergency etc or to comply with another rule

It is a defence to the prosecution of a driver for an offence against a provision of this Part if:

- (a) the driver stops at a particular place, or in a particular way, to avoid a collision, and the driver stops for no longer than is necessary to avoid the collision; or
- (b) the driver stops at a particular place, or in a particular way, because the driver's vehicle is disabled, and the driver stops for no longer than is necessary for the vehicle to be moved safely to a place where the driver is permitted to park the vehicle under the *Australian Road Rules*; or
- (c) the driver stops at a particular place, or in a particular way, to deal with a medical or other emergency, and the driver stops for no longer than is necessary in the circumstances; or
- (d) the driver stops at a particular place, or in a particular way, because the condition of the driver, a passenger, or the driver's vehicle makes it necessary for the driver to stop in the interests of safety, and the driver stops for no longer than is necessary in the circumstances; or
- (e) the driver stops at a particular place, or in a particular way, to comply with another provision of the *Australian Road Rules* or a provision of another law, and the driver stops for no longer than is necessary to comply with the other provision.

*Example for paragraph (e)*

If a driver stops at an intersection at a stop line, *stop sign*, or traffic lights, or to give way to a vehicle, in accordance with the *Australian Road Rules*, the driver does not contravene rule 170 (stopping in or near an intersection).

*Note* **Driver's vehicle** is defined in the dictionary.

#### 166 Application of Part to bicycles

This Part does not apply to a bicycle that is parked at a bicycle rail or in a bicycle rack.

*Note* **Bicycle** is defined in the dictionary.

## Division 2 No stopping and no parking signs and road markings

*Note 1* *Area*, *length* of road, *park* and *stop* are defined in the dictionary.

*Note 2* Rule 165 provides defences to the prosecution of a driver for an offence against a provision of this Division.

### 167 No stopping signs

A driver must not stop on a length of road or in an area to which a *no stopping sign* applies.

Offence provision.

*Note* Another law of this jurisdiction may provide transitional arrangements dealing with *no standing signs*.

#### No stopping signs

No stopping sign  
(for a length of road)

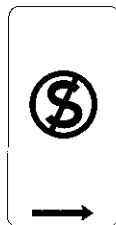

No stopping sign  
(for an area)



*Note 1 for diagrams* There are a number of other permitted versions of these signs — see the diagrams in Schedule 3.

*Note 2 for diagrams* A *no stopping sign* may have an arrow pointing in a different direction and anything on the sign may be differently arranged — see rule 316 (4).

### 168 No parking signs

- (1) The driver of a vehicle must not stop on a length of road or in an area to which a *no parking sign* applies, unless the driver:
- is dropping off, or picking up, passengers or goods; and
  - does not leave the vehicle unattended; and
  - completes the dropping off, or picking up, of the passengers or goods, and drives on, as soon as possible and, in any case, within the required time after stopping.

Offence provision.

- (2) For this rule, a driver leaves a vehicle *unattended* if the driver leaves the vehicle so the driver is over 3 metres from the closest point of the vehicle.



(3) In this rule:

**required time** means:

- (a) 2 minutes; or
- (b) if information on or with the sign indicates another time — the indicated time.

*Note* **With** is defined in the dictionary.

No parking signs

No parking sign  
(for a length of road)



No parking sign  
(for an area)



*Note 1 for diagrams* There are a number of other permitted versions of each of these signs — see the diagrams in Schedule 3.

*Note 2 for diagrams* A *no parking sign* may have an arrow pointing in a different direction and anything on the sign may be differently arranged — see rule 316 (4).

**169 No stopping on a road with a yellow edge line**

A driver must not stop at the side of a road marked with a continuous yellow edge line.

Offence provision.

*Note* **Edge line** is defined in the dictionary.

## Division 3 Stopping at intersections and crossings

*Note 1* **Area**, **length** of road, **park** and **stop** are defined in the dictionary.

*Note 2* Rule 165 provides defences to the prosecution of a driver for an offence against a provision of this Division.

### 170 Stopping in or near an intersection

- (1) A driver must not stop in an intersection.

Offence provision.

*Note* **Intersection** is defined in the dictionary.

- (2) A driver must not stop on a road within 20 metres from the nearest point of an intersecting road at an intersection with traffic lights, unless the driver stops at a place on a length of road, or in an area, to which a parking control sign applies and the driver is permitted to stop at that place under the *Australian Road Rules*.

Offence provision.

*Note 1* **Parking control sign** and **traffic lights** are defined in the dictionary.

*Note 2* A driver stops within a particular distance from an intersection if the driver stops so any part of the driver's vehicle is within that distance — see rule 350 (2).

- (3) A driver must not stop on a road within 10 metres from the nearest point of an intersecting road at an intersection without traffic lights, unless the driver stops:
- (a) at a place on a length of road, or in an area, to which a parking control sign applies and the driver is permitted to stop at that place under the *Australian Road Rules*; or
  - (b) if the intersection is a T-intersection — along the continuous side of the continuing road at the intersection.

Offence provision.

*Note* **Continuing road** and **T-intersection** are defined in the dictionary.

- (4) For this rule, distances are measured in the direction in which the driver is driving, and:
- (a) for subrule (2) — as shown in example 1; or
  - (b) for subrule (3) — as shown in example 2.

- (5) In this rule:

**road** does not include a road-related area, but includes any shoulder of the road.

*Note* **Road-related area** is defined in rule 13, and **shoulder** is defined in rule 12.

*Examples*

Example 1  
Measurement of distance — intersection with traffic lights

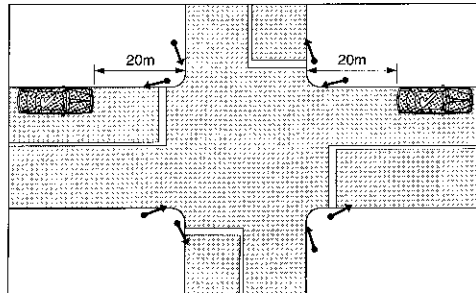

Example 2  
Measurement of distance — T-intersection without traffic lights

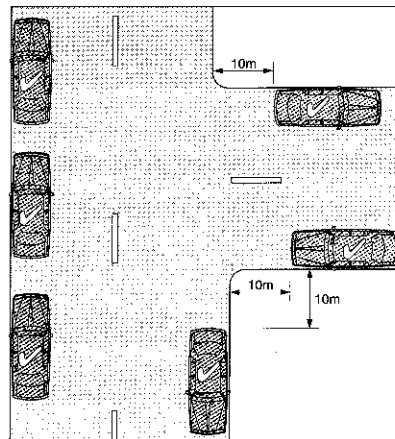

**171 Stopping on or near a children's crossing**

- (1) A driver must not stop on a children's crossing, or on the road within 20 metres before the crossing and 10 metres after the crossing, unless the driver stops at a place on a length of road, or in an area, to which a parking control sign applies and the driver is permitted to stop at that place under the *Australian Road Rules*.

Offence provision.

*Note 1* **Children's crossing** is defined in rule 80, and **parking control sign** is defined in the dictionary.

*Note 2* A driver stops within a particular distance from a children's crossing if the driver stops so any part of the driver's vehicle is within that distance — see rule 350 (2).

- (2) For this rule, distances are measured:
  - (a) in the direction in which the driver is driving; and
  - (b) as shown in example 1 or 2.
- (3) In this rule:

**road** does not include a road-related area, but includes any shoulder of the road.

*Note* **Road-related area** is defined in rule 13, and **shoulder** is defined in rule 12.

*Examples*

Example 1

Measurement of distance — children's crossing with red and white posts

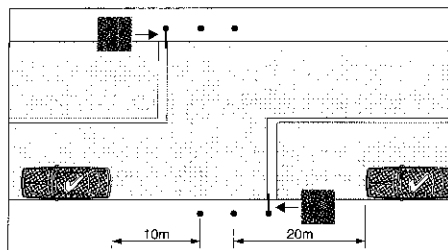

Example 2

Measurement of distance — children's crossing with 2 parallel continuous or broken lines

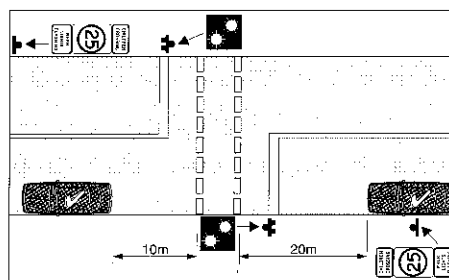

**172 Stopping on or near a pedestrian crossing (except at an intersection)**

- (1) A driver must not stop on a pedestrian crossing that is not at an intersection, or on the road within 20 metres before the crossing and 10 metres after the crossing, unless the driver stops at a place on a length of road, or in an area, to which a parking control sign applies and the driver is permitted to stop at that place under the *Australian Road Rules*.

Offence provision.

*Note 1* **Intersection** and **parking control sign** are defined in the dictionary, and **pedestrian crossing** is defined in rule 81.

*Note 2* A driver stops within a particular distance from a crossing if the driver stops so any part of the driver's vehicle is within that distance — see rule 350 (2).

- (2) For this rule, distances are measured:
- (a) in the direction in which the driver is driving; and
  - (b) as shown in the example.

- (3) In this rule:

**road** does not include a road-related area, but includes any shoulder of the road.

*Note* **Road-related area** is defined in rule 13, and **shoulder** is defined in rule 12.

*Example*

Measurement of distance — pedestrian crossing

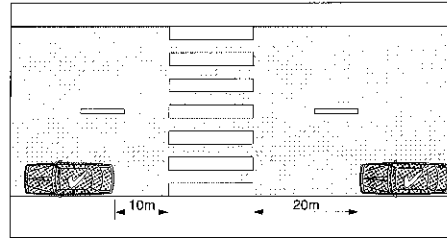

**173 Stopping on or near a marked foot crossing (except at an intersection)**

- (1) A driver must not stop on a marked foot crossing that is not at an intersection, or on the road within 10 metres before the traffic lights pole nearest to the driver at the crossing and 3 metres after the crossing, unless the driver stops at a place on a length of road, or in an area, to which a parking control sign applies and the driver is permitted to stop at that place under the *Australian Road Rules*.

Offence provision.

*Note 1* **Intersection**, **marked foot crossing**, **parking control sign** and **traffic lights pole** are defined in the dictionary.

*Note 2* A driver stops within a particular distance from a traffic lights pole or a crossing if the driver stops so any part of the driver's vehicle is within that distance — see rule 350 (2).

- (2) For this rule, distances are measured:  
(a) in the direction in which the driver is driving; and  
(b) as shown in the example.

- (3) In this rule:

**road** does not include a road-related area, but includes any shoulder of the road.

*Note* **Road-related area** is defined in rule 13, and **shoulder** is defined in rule 12.

*Example*

Measurement of distance — marked foot crossing

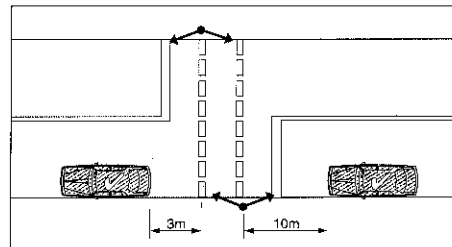

### 174 Stopping at or near bicycle crossing lights (except at an intersection)

- (1) This rule applies to a place on a road:
  - (a) with bicycle crossing lights facing bicycle riders crossing the road; and
  - (b) with traffic lights facing traffic travelling on the road; and
  - (c) that is not at an intersection.

*Note* **Bicycle crossing lights**, **intersection** and **traffic lights** are defined in the dictionary.

- (2) A driver must not stop within 10 metres before the traffic lights nearest to the driver at the place, and 3 metres after the traffic lights, unless the driver stops at a place on a length of road, or in an area, to which a parking control sign applies and the driver is permitted to stop at that place under the *Australian Road Rules*.

Offence provision.

*Note 1* **Parking control sign** is defined in the dictionary.

*Note 2* A driver stops within a particular distance from traffic lights if the driver stops so any part of the driver's vehicle is within that distance — see rule 350 (2).

- (3) For this rule, distances are measured:
  - (a) in the direction in which the driver is driving; and
  - (b) as shown in the example.

- (4) In this rule:

**road** does not include a road-related area, but includes any shoulder of the road.

*Note* **Road-related area** is defined in rule 13, and **shoulder** is defined in rule 12.

*Example*

Measurement of distance — bicycle crossing lights

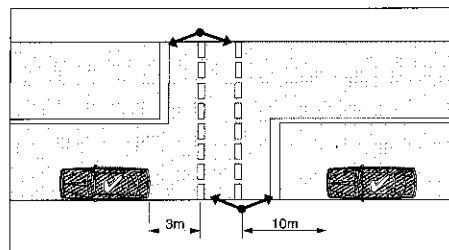

### 175 Stopping on or near a level crossing

- (1) A driver must not stop on a level crossing, or on a road within 20 metres before the nearest rail or track to the driver approaching the crossing and 20 metres after the nearest rail or track to the driver leaving the crossing, unless the driver stops at a place on a length of road, or in an area, to which a parking control sign applies and the driver is permitted to stop at that place under the *Australian Road Rules*.

Offence provision.

*Note 1* **Level crossing** is defined in rule 120, and **parking control sign** is defined in the dictionary.

*Note 2* A driver stops within a particular distance from a level crossing if the driver stops so any part of the driver's vehicle is within that distance — see rule 350 (2).

- (2) For this rule, distances are measured as shown in the example.

(3) In this rule:

**road** does not include a road-related area, but includes any shoulder of the road.

*Note* **Road-related area** is defined in rule 13, and **shoulder** is defined in rule 12.

*Example*

Measurement of distance — level crossing

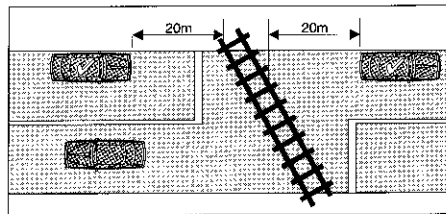

## Division 4 Stopping on clearways and freeways and in emergency stopping lanes

*Note 1* *Area, length* of road, *park* and *stop* are defined in the dictionary.

*Note 2* Rule 165 provides defences to the prosecution of a driver for an offence against a provision of this Division.

### 176 Stopping on a clearway

- (1) A driver must not stop on a length of road to which a *clearway sign* applies, unless subrule (2) or (3) applies to the driver.

Offence provision.

- (2) The driver of a public bus or public minibus may stop on the length of road if the driver is dropping off, or picking up, passengers.

*Note* *Public bus* and *public minibus* are defined in the dictionary.

- (3) The driver of a taxi may stop on the length of road if:

- (a) the driver is dropping off, or picking up, passengers; and
- (b) there is not another law of this jurisdiction prohibiting the driver of a taxi from stopping on a length of road to which a *clearway sign* applies.

*Note* *Taxi* is defined in the dictionary.

- (4) If a *clearway sign* on a road indicates the days or times when it applies, the sign applies to the length of road beginning at the sign and ending at the nearer of the following:

- (a) a *clearway sign* on the road that indicates different days or times;
- (b) an *end clearway sign* on the road.

- (5) If a *clearway sign* on a road does not indicate the days or times when it applies, the sign applies to the length of road beginning at the sign and ending at the nearer of the following:

- (a) a *clearway sign* on the road that indicates the days or times when it applies;
- (b) an *end clearway sign* on the road.

Clearway sign

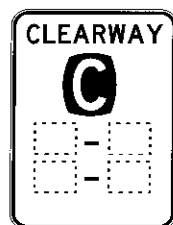

End clearway sign

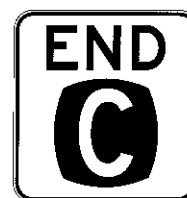

*Note for diagrams* Anything on these signs may be differently arranged — see rule 316 (4).



### 177 Stopping on a freeway

- (1) A driver must not stop on a freeway unless:
- (a) the driver stops in an emergency stopping lane; or
  - (b) the driver's vehicle is permitted to stop on the freeway under another law of this jurisdiction.

Offence provision.

*Note 1* **Driver's vehicle** is defined in the dictionary, and **emergency stopping lane** is defined in rule 95.

*Note 2* Rule 178 sets out when a driver can stop in an emergency stopping lane.

- (2) A **freeway** is a length of road to which a *freeway sign* applies.
- (3) A *freeway sign* on a road applies to a length of road beginning at the sign (including any road into which the length of road merges) and ending at the next *end freeway sign* on the road.

Freeway signs



End freeway sign



*Note for diagrams* There are a number of other permitted versions of each of these signs — see the diagrams in Schedule 3.

### 178 Stopping in an emergency stopping lane

A driver (except the rider of a bicycle) must not stop in an emergency stopping lane unless:

- (a) the condition of the driver, a passenger or the driver's vehicle, or any other factor, makes it necessary or desirable for the driver to stop in the emergency stopping lane in the interests of safety, and the driver stops for no longer than is necessary in the circumstances; or
- (b) the driver is permitted to stop in the emergency stopping lane under another law of this jurisdiction.

Offence provision.

*Note* **Bicycle** and **driver's vehicle** are defined in the dictionary, and **emergency stopping lane** is defined in rule 95.

## Division 5 Stopping in zones for particular vehicles

*Note 1* **Area, length** of road, **park** and **stop** are defined in the dictionary.

*Note 2* Rule 165 provides defences to the prosecution of a driver for an offence against a provision of this Division.

*Note 3* The signs mentioned to in this Division are particular types of **parking control sign** (defined in the dictionary) to which the general rules about the application of parking control signs apply—see rules 332 to 335.

### 179 Stopping in a loading zone

- (1) A driver must not stop in a loading zone unless the driver is driving:
  - (a) a public bus that is dropping off, or picking up, passengers; or
  - (b) a truck that is dropping off, or picking up, goods; or
  - (c) a vehicle that is permitted to stop in the loading zone under another law of this jurisdiction.

Offence provision.

*Note* **Public bus** and **truck** are defined in the dictionary.

- (2) A driver who is permitted to stop in a loading zone must not stay continuously in the zone for longer than:
  - (a) 30 minutes; or
  - (b) if information on or with the *loading zone signs* applying to the loading zone indicates another time — the indicated time.

Offence provision.

*Note* **With** is defined in the dictionary.

- (3) A **loading zone** is a length of a road to which a *loading zone sign* applies.

Loading zone sign

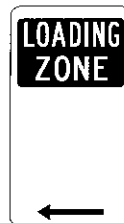

*Note 1 for diagram* There are a number of other permitted versions of this sign — see the diagrams in Schedule 3.

*Note 2 for diagram* A *loading zone sign* may have an arrow pointing in a different direction and anything on the sign may be differently arranged — see rule 316 (4).

### 180 Stopping in a truck zone

- (1) A driver must not stop in a truck zone unless the driver is driving:
  - (a) a truck that is dropping off, or picking up, goods; or
  - (b) a vehicle that is permitted to stop in the truck zone under another law of this jurisdiction.

Offence provision.

*Note* **Truck** is defined in the dictionary.

- (2) A **truck zone** is a length of a road to which a *truck zone sign* applies.

Truck zone sign

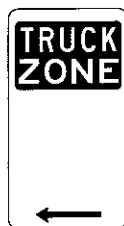

*Note 1 for diagram* There is another permitted version of this sign — see the diagram in Schedule 3.

*Note 2 for diagram* A *truck zone sign* may have an arrow pointing in a different direction and anything on the sign may be differently arranged — see rule 316 (4).

### 181 Stopping in a works zone

- (1) A driver must not stop in a works zone unless the driver is driving a vehicle that is:
  - (a) engaged in construction work in or near the zone; or
  - (b) permitted to stop in the works zone under another law of this jurisdiction.

Offence provision.

- (2) A **works zone** is a length of a road to which a *works zone sign* applies.

Works zone sign

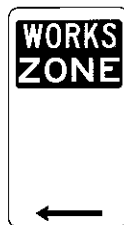

*Note 1 for diagram* There is another permitted version of this sign — see the diagram in Schedule 3.

*Note 2 for diagram* A *works zone sign* may have an arrow pointing in a different direction and anything on the sign may be differently arranged — see rule 316 (4).

### 182 Stopping in a taxi zone

- (1) A driver must not stop in a taxi zone, unless the driver is driving a taxi.

Offence provision.

*Note* **Taxi** is defined in the dictionary.

- (2) A **taxi zone** is a length of a road to which a *taxi zone sign* applies.

Taxi zone sign



*Note 1 for diagram* There are a number of other permitted versions of this sign — see the diagrams in Schedule 3.

*Note 2 for diagram* A *taxi zone sign* may have an arrow pointing in a different direction and anything on the sign may be differently arranged — see rule 316 (4).

### 183 Stopping in a bus zone

- (1) A driver must not stop in a bus zone unless the driver is driving a public bus (except a public bus of a kind that is not permitted to stop in the bus zone by information on or with the *bus zone sign* applying to the bus zone).

Offence provision.

*Note* **Public bus** and **with** are defined in the dictionary.

- (2) A **bus zone** is a length of a road to which a *bus zone sign* applies.

Bus zone sign

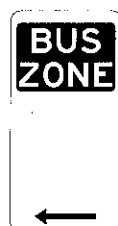

*Note 1 for diagram* There are a number of other permitted versions of this sign — see the diagrams in Schedule 3.

*Note 2 for diagram* A *bus zone sign* may have an arrow pointing in a different direction and anything on the sign may be differently arranged — see rule 316 (4).

### 184 Stopping in a minibus zone

- (1) A driver (except the driver of a public minibus) must not stop in a minibus zone.

Offence provision.

*Note* **Public minibus** is defined in the dictionary.

- (2) A *minibus zone* is a length of road to which a *minibus zone sign* applies.

Minibus zone sign



*Note for diagram* A *minibus zone sign* may have an arrow pointing in a different direction and anything on the sign may be differently arranged — see rule 316 (4).

### 185 Stopping in a permit zone

- (1) A driver must not stop in a permit zone unless the driver's vehicle displays a current permit issued under another law of this jurisdiction that permits the vehicle to stop in the zone.

Offence provision.

*Note* *Driver's vehicle* is defined in the dictionary.

- (2) A *permit zone* is a length of a road to which a *permit zone sign* applies.

Permit zone sign

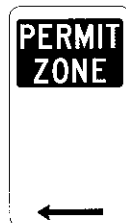

*Note 1 for diagram* There are a number of other permitted versions of this sign — see the diagrams in Schedule 3.

*Note 2 for diagram* A *permit zone sign* may have an arrow pointing in a different direction and anything on the sign may be differently arranged — see rule 316 (4).

### 186 Stopping in a mail zone

- (1) A driver must not stop in a mail zone.

Offence provision.

(2) A *mail zone* is a length of a road to which a *mail zone sign* applies.

*Note* Exemptions for drivers of postal vehicles may be provided under rule 313.

Mail zone sign

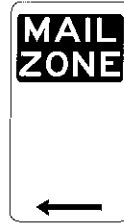

*Note for diagram* A *mail zone sign* may have an arrow pointing in a different direction and anything on the sign may be differently arranged — see rule 316 (4).

## **Division 6 Other places where stopping is restricted**

*Note 1* *Area*, *length* of road, *park* and *stop* are defined in the dictionary.

*Note 2* Rule 165 provides defences to the prosecution of a driver for an offence against a provision of this Division.

### **187 Stopping in a bicycle lane, bus lane, tram lane, transit lane, truck lane or on tram tracks**

- (1) A driver must not stop in a bus lane, transit lane or truck lane unless the driver:
- (a) is driving a public bus, public minibus or taxi, and is dropping off, or picking up, passengers; and
  - (b) is permitted to drive in the lane under the *Australian Road Rules* or another law of this jurisdiction.

Offence provision.

- (2) A driver must not stop in a bicycle lane unless:
- (a) the driver:
    - (i) is driving a public bus, public minibus or taxi, and is dropping off or picking up, passengers; and
    - (ii) is permitted to drive in the lane under the *Australian Road Rules* or another law of this jurisdiction; or
  - (b) the driver is permitted to stop or park in the bicycle lane under another law of this jurisdiction.

Offence provision.

- (3) A driver (except the driver of a tram or a public bus) must not stop in a tram lane, or on tram tracks.

Offence provision.

*Note 1* *Bicycle lane* is defined in rule 153, *bus lane* is defined in rule 154, *tram lane* is defined in rule 155, *transit lane* is defined in rule 156, *truck lane* is defined in rule 157, and *public bus*, *public minibus*, *taxi*, *tram* and *tram tracks* are defined in the dictionary.

*Note 2* Rule 76 deals with drivers keeping clear of trams travelling in tram lanes or on tram tracks marked on each side by a yellow line.

*Note 3* Part 11, Division 6 deals with driving in bicycle lanes, bus lanes, tram lanes, transit lanes and truck lanes.

**Rule 188**

**188 Stopping in a shared zone**

A driver must not stop in a shared zone unless:

- (a) the driver stops at a place on a length of road, or in an area, to which a parking control sign applies and the driver is permitted to stop at that place under the *Australian Road Rules*; or
- (b) the driver stops in a parking bay and the driver is permitted to stop in the parking bay under the *Australian Road Rules*; or
- (c) the driver is dropping off, or picking up, passengers or goods; or
- (d) the driver is engaged in the door-to-door delivery or collection of goods, or in the collection of waste or garbage.

Offence provision.

Note *Parking bay* and *parking control sign* are defined in the dictionary, and *shared zone* is defined in rule 24.

**189 Double parking**

(1) A driver must not stop on a road:

- (a) if the road is a two-way road — between the centre of the road and another vehicle that is parked at the side of the road; or
- (b) if the road is a one-way road — between the far side of the road and another vehicle that is parked at the side of the road.

Offence provision.

Note *One-way road* and *two-way road* are defined in the dictionary.

(2) A driver does not contravene this rule by parking on the side of the road, or in a median strip parking area, in accordance with rule 210.

Note *Median strip parking area* is defined in the dictionary.

Examples

Example 1

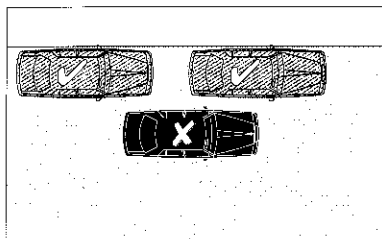

Example 2

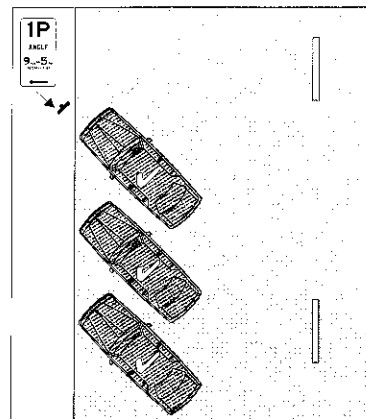

In example 1, the vehicle marked with an 'X' is stopped in contravention of this rule.

In example 2, the angle parked vehicles are not stopped in contravention of this rule.



## 190 Stopping in or near a safety zone

- (1) A driver must not stop in a safety zone, or on a road within 10 metres before or after a safety zone, unless the driver stops at a place on a length of road, or in an area, to which a parking control sign applies and the driver is permitted to stop at that place under the *Australian Road Rules*.

Offence provision.

*Note 1* **Parking control sign** is defined in the dictionary, and **safety zone** is defined in rule 162.

*Note 2* A driver stops within a particular distance before or after something if the driver stops so any part of the vehicle is within that distance — see rule 350 (2).

- (2) For this rule, distances are measured:
- (a) in the direction in which the driver is driving; and
  - (b) from the end of the structure; and
  - (c) as shown in the example.

- (3) In this rule:

**road** does not include a road-related area, but includes any shoulder of the road.

*Note* **Road-related area** is defined in rule 13, and **shoulder** is defined in rule 12.

Safety zone sign



*Example*

Measurement of distance — safety zone

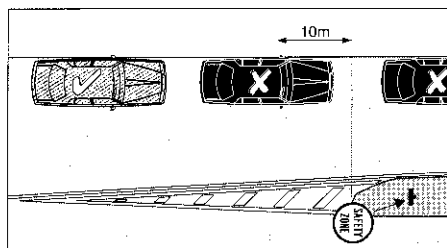

In the example, the vehicles marked with an 'X' are stopped in contravention of this rule.

## 191 Stopping near an obstruction

A driver must not stop on a road near an obstruction on the road in a position that obstructs traffic on the road.

Offence provision.

*Note* **Obstruction** is defined in the dictionary.

### 192 Stopping on a bridge or in a tunnel etc

- (1) A driver must not stop on a bridge, causeway, ramp or similar structure unless:
- (a) the road is at least as wide on the structure as it is on each of the approaches; or
  - (b) the driver stops at a place on a length of road, or in an area, to which a parking control sign applies and the driver is permitted to stop at that place under the *Australian Road Rules*.

Offence provision.

*Note* **Parking control sign** is defined in the dictionary.

- (2) A driver must not stop in a tunnel or underpass unless:
- (a) the road is at least as wide in the tunnel or underpass as it is on each of the approaches; or
  - (b) the driver stops at a place on a length of road, or in an area, to which a parking control sign applies and the driver is permitted to stop at that place under the *Australian Road Rules*.

Offence provision.

*Example*

Stopping on a bridge where the road on the bridge is narrower than on an approach

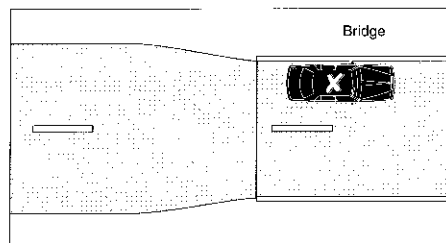

In the example, the vehicle is stopped in contravention of subrule (1).

### 193 Stopping on a crest or curve outside a built-up area

- (1) A driver must not stop on or near a crest or curve on a length of road that is not in a built-up area unless:
- (a) the driver's vehicle is visible for 100 metres to drivers approaching the vehicle and travelling in the direction of travel of traffic on the same side of the road as the vehicle; or
  - (b) the driver stops at a place on a length of road, or in an area, to which a parking control sign applies and the driver is permitted to stop at that place under the *Australian Road Rules*.

Offence provision.

*Note* **Built-up area**, **driver's vehicle** and **parking control sign** are defined in the dictionary.

- (2) In this rule:

**road** does not include a road-related area, but includes any shoulder of the road.

*Note* **Road-related area** is defined in rule 13, and **shoulder** is defined in rule 12.

### 194 Stopping near a fire hydrant etc

- (1) A driver must not stop within 1 metre of a fire hydrant, fire hydrant indicator, or fire plug indicator, unless:
  - (a) the driver is driving a public bus, and the driver stops at a bus stop or in a bus zone and does not leave the bus unattended; or
  - (b) the driver is driving a taxi, and the driver stops in a taxi zone and does not leave the taxi unattended; or
  - (c) the driver is driving a public minibus, and the driver stops in a minibus zone and does not leave the minibus unattended.

Offence provision.

*Note* **Bus zone** is defined in rule 183, **public bus**, **public minibus** and **taxi** are defined in the dictionary, **minibus zone** is defined in rule 184, and **taxi zone** is defined in rule 182.

- (2) For this rule, a driver leaves a vehicle **unattended** if the driver leaves the vehicle so the driver is over 3 metres from the closest point of the vehicle.
- (3) In this rule:

**fire hydrant** means an upright pipe with a spout, nozzle or other outlet for drawing water from a main or service pipe in case of fire or other emergency.

*Examples*

Fire hydrant indicators

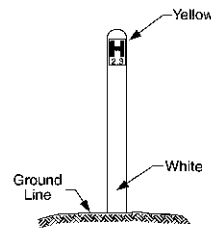
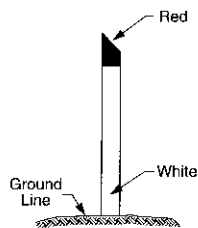

Fire plug indicator

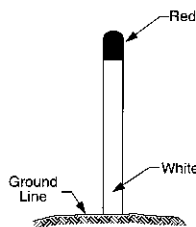

### **195 Stopping at or near a bus stop**

- (1) A driver (except the driver of a public bus) must not stop at a bus stop, or on the road, within 20 metres before a sign on the road that indicates the bus stop, and 10 metres after the sign, unless the driver stops at a place on a length of road, or in an area, to which a parking control sign applies and the driver is permitted to stop at that place under the *Australian Road Rules*.

Offence provision.

*Note 1* **Parking control sign** and **public bus** are defined in the dictionary.

*Note 2* A driver stops within a particular distance before or after a sign indicating a bus stop if the driver stops so any part of the driver's vehicle is within that distance — see rule 350 (2).

- (2) For this rule, distances are measured in the direction in which the driver is driving.

- (3) In this rule:

**road** does not include a road-related area, but includes any shoulder of the road.

*Note* **Road-related area** is defined in rule 13, and **shoulder** is defined in rule 12.

### **196 Stopping at or near a tram stop**

- (1) A driver (except the driver of a tram or a public bus travelling along tram tracks) must not stop at a tram stop or on the road within 10 metres before a sign on the road displaying the words 'tram stop' or 'tram stop request'.

Offence provision.

*Note 1* **Public bus**, **tram** and **travelling along tram tracks** are defined in the dictionary.

*Note 2* A driver stops within a particular distance before a sign indicating a tram stop if the driver stops so any part of the driver's vehicle is within that distance — see rule 350 (2).

- (2) For this rule, the distance is measured in the direction in which the driver is driving.

- (3) In this rule:

**road** does not include a road-related area, but includes any shoulder of the road.

*Note* **Road-related area** is defined in rule 13, and **shoulder** is defined in rule 12.

### **197 Stopping on a path, dividing strip or nature strip**

- (1) A driver must not stop on a bicycle path, footpath, shared path or dividing strip, or a nature strip adjacent to a length of road in a built-up area, unless:
- (a) the driver stops at a place on a length of road, or in an area, to which a parking control sign applies and the driver is permitted to stop at that place under the *Australian Road Rules*; or
  - (b) the driver is permitted to stop under another law of this jurisdiction.

Offence provision.

*Note 1* **Bicycle path** is defined in rule 239, **built-up area**, **dividing strip**, **footpath**, **nature strip** and **parking control sign** are defined in the dictionary, and **shared path** is defined in rule 242.

*Note 2* A **separated footpath** is a particular kind of footpath — see rule 239.

- (2) This rule does not apply to the rider of a bicycle or animal.

*Note* **Bicycle** is defined in the dictionary.

## 198 Obstructing access to and from a footpath, driveway etc

- (1) A driver must not stop on a road in a position that obstructs access by vehicles or pedestrians to or from a footpath ramp or a similar way of access to a footpath, or a bicycle path or passageway unless:
- (a) the driver is driving a public bus that is dropping off, or picking up, passengers; or
  - (b) the driver stops in a parking bay and the driver is permitted to stop in the parking bay under the *Australian Road Rules*.

Offence provision.

*Note* **Bicycle path** is defined in rule 239, and **footpath**, **parking bay** and **public bus** are defined in the dictionary.

- (2) A driver must not stop on or across a driveway or other way of access for vehicles travelling to or from adjacent land unless:
- (a) the driver is dropping off, or picking up, passengers; or
  - (b) the driver stops in a parking bay and the driver is permitted to stop in the parking bay under the *Australian Road Rules*.

Offence provision.

*Note 1* **Adjacent land** is defined in the dictionary.

*Note 2* A driver stops on or across a driveway or way of access if any part of the vehicle is on or across the driveway or way of access — see rule 350.

*Example*

Blocking a driveway

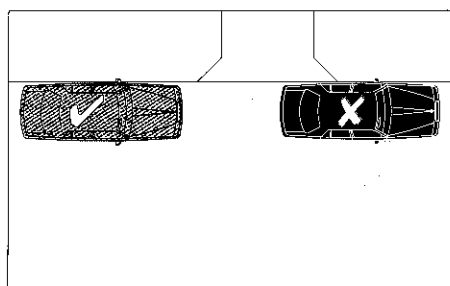

In the example, the vehicle marked with an 'X' is stopped in contravention of subrule (2).

## 199 Stopping near a postbox

- (1) A driver must not stop on a road within 3 metres of a public postbox, unless the driver:
- (a) is dropping off, or picking up, passengers or mail; or
  - (b) stops at a place on a length of road, or in an area, to which a parking control sign applies and the driver is permitted to stop at that place under the *Australian Road Rules*.

Offence provision.

*Note* **Parking control sign** is defined in the dictionary.

- (2) In this rule:

**public postbox** means a structure that is declared to be a public postbox, for the *Australian Road Rules*, under another law of this jurisdiction.

## 200 Stopping on roads — heavy and long vehicles

- (1) The driver of a heavy vehicle, or long vehicle, must not stop on a length of road that is not in a built-up area, except on the shoulder of the road.

Offence provision.

*Note* **Built-up area** is defined in the dictionary, and **shoulder** is defined in rule 12.

- (2) The driver of a heavy vehicle, or long vehicle, must not stop on a length of road in a built-up area for longer than 1 hour, unless the driver is permitted to stop on the length of road for longer than 1 hour by information on or with a traffic control device, or under another law of this jurisdiction.

Offence provision.

*Note* **Traffic control device** and **with** are defined in the dictionary.

- (3) In this rule:

**heavy vehicle** means a vehicle with a GVM of 4.5 tonnes or more.

**long vehicle** means a vehicle that, together with any load or projection, is 7.5 metres long, or longer.

**road** does not include a road-related area, but includes any shoulder of the road.

*Note 1* **GVM** is defined in the dictionary, **road-related area** is defined in rule 13, and **shoulder** is defined in rule 12.

*Note 2* **Vehicle** includes a combination — see rule 15 (d).

## 201 Stopping on a road with bicycle parking sign

A driver (except the rider of a bicycle) must not stop on a length of road to which a *bicycle parking sign* applies, unless the driver is dropping off, or picking up, passengers.

Offence provision.

*Note* **Bicycle** is defined in the dictionary.

Bicycle parking sign



*Note for diagram* Anything on this sign may be differently arranged — see rule 316 (4).

**202 Stopping on a road with motor bike parking sign**

A driver (except the rider of a motor bike) must not stop on a length of road to which a *motor bike parking sign* applies, unless the driver is dropping off, or picking up, passengers.

Offence provision.

*Note* **Motor bike** is defined in the dictionary.

Motor bike parking sign

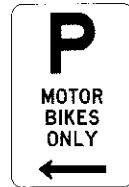

*Note for diagram* Anything on this sign may be differently arranged — see rule 316 (4).

**203 Stopping in a parking area for people with disabilities**

- (1) A driver must not stop in a parking area for people with disabilities unless:
- (a) the driver's vehicle displays a current parking permit for people with disabilities; and
  - (b) the driver complies with the conditions of use of the permit.

Offence provision.

*Note* **Driver's vehicle** and **parking permit for people with disabilities** are defined in the dictionary.

- (2) A **parking area for people with disabilities** is a length or area of a road:
- (a) to which a *permissive parking sign* displaying a people with disabilities symbol applies; or
  - (b) to which a *people with disabilities parking sign* applies; or
  - (c) indicated by a road marking (a **people with disabilities road marking**) that consists of, or includes, a people with disabilities symbol.

People with disabilities symbols



Permissive parking sign displaying a people with disabilities symbol  
(for a length of road)



Permissive parking sign displaying a people with disabilities symbol  
(for an area)



People with disabilities parking sign



*Note for diagrams* Anything on these signs may be differently arranged — see rule 316 (4).



## Division 7 Permissive parking signs and parking fees

*Note 1* *Area, length* of road, *park* and *stop* are defined in the dictionary.

*Note 2* Rule 165 provides defences to the prosecution of a driver for an offence against a provision of this Division.

### 204 Meaning of certain information on or with permissive parking signs

- (1) This rule explains the meaning of certain information on or with a *permissive parking sign* applying to a length of road or an area.

*Note* *With* is defined in the dictionary.

Permissive parking sign  
(for a length of road)

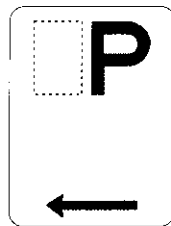

Permissive parking sign  
(for an area)

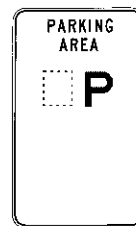

Permissive parking sign  
(for a length of road)

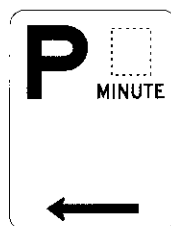

*Note 1 for diagrams* There are a number of other permitted versions of each of these signs — see the diagrams in Schedule 3.

*Note 2 for diagrams* A *permissive parking sign* may have an arrow pointing in a different direction and anything on the sign may be differently arranged — see rule 316 (4).

*Note* Rule 318 (1) and (2) deal with the effect of information on or with a traffic control device (including a *permissive parking sign*) that limits the application of the device to particular times or days. Under rule 318 (3), if the information indicates that the device applies on a particular day, for example Friday, the sign does not have effect on a Friday that is a public holiday unless otherwise stated.

- (2) A whole number, fraction, or whole number and fraction, immediately to the left of the letter 'P' indicates that a driver must not park on the length of road, or in the area, continuously for longer than the period of hours, or fraction of an hour, equal to the number, fraction, or number and fraction, shown.

*Examples of permissive parking signs showing permitted parking periods and times of operation*

Example 1  
 Permissive parking sign  
 applying to a length of road with a whole  
 number to the left of P

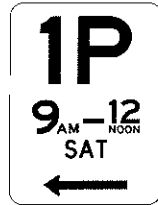

Example 2  
 Permissive parking sign  
 applying to an area with a whole number to the  
 left of P

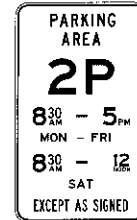

In example 1, the sign indicates that a driver must not park continuously for longer than 1 hour on Saturdays between 9 am and 12 noon.

In example 2, the sign indicates that a driver must not park in the area for longer than 2 hours on Mondays to Fridays between 8.30 am and 5 pm, and on Saturdays between 8.30 am and 12 noon, unless permitted by information on or with another traffic control device.

- (3) A number, together with the word 'minute', immediately to the right of the letter 'P' indicate that a driver must not park on the length of road, or in the area, continuously for longer than the number of minutes shown.

*Example*

Example 3  
 Permissive parking sign with a number of minutes to the right of P

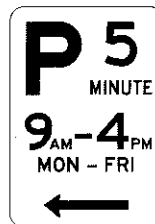

In this example, the sign indicates that a driver must not park continuously for longer than 5 minutes on Mondays to Fridays between 9 am and 4 pm.

- (4) The word 'parking', together with words indicating a number of hours or minutes, indicate that a driver must not park on the length of road, or in the area, continuously for longer than the number of hours or minutes shown.

**205 Parking for longer than indicated**

A driver must not park continuously on a length of road, or in an area, to which a *permissive parking sign* applies for longer than the period indicated by information on or with the sign or, if rule 206 applies to the driver, the period allowed under that rule.

Offence provision.

*Note* **With** is defined in the dictionary.

## **206 Time extension for people with disabilities**

- (1) This rule applies to a driver:
  - (a) if the driver's vehicle displays a current parking permit for people with disabilities; and
  - (b) the driver complies with the conditions of use of the permit.

*Note* **Driver's vehicle** and **parking permit for people with disabilities** are defined in the dictionary.

- (2) The driver may park continuously on a length of road, or in an area, to which a *permissive parking sign* applies (except in a parking area for people with disabilities) for:
  - (a) twice the period indicated on the sign; or
  - (b) if another law of this jurisdiction permits the driver to park for a longer period — the longer period; or
  - (c) if another law of this jurisdiction permits the driver to park for an unlimited period — an unlimited period.

*Note* **Parking area for people with disabilities** is defined in rule 203.

## **207 Parking where fees are payable**

- (1) This rule applies to a driver who parks on a length of road, or in an area, to which a *permissive parking sign* applies if information on or with the sign indicates that a fee is payable for parking by buying a ticket or putting money into a parking meter.

*Note* **With** is defined in the dictionary.

- (2) The driver must:
  - (a) pay the fee (if any) payable under the law of this jurisdiction; and
  - (b) obey any instructions on or with the sign, meter, ticket or ticket-vending machine.

Offence provision.

## **Division 8      Parallel parking**

*Note 1* **Area**, **length** of road, **park** and **stop** are defined in the dictionary.

*Note 2* Rule 165 provides defences to the prosecution of a driver for an offence against a provision of this Division.

### **208 Parallel parking on a road (except in a median strip parking area)**

- (1) A driver who parks on a road (except in a median strip parking area) must position the driver's vehicle in accordance with subrules (2) to (8).

Offence provision.

*Note* **Driver's vehicle** and **median strip parking area** are defined in the dictionary.

- (2) The driver must position the vehicle to face in the direction of travel of vehicles in the marked lane or line of traffic on, or next to, the part of the road where the driver parks.

*Note* **Marked lane** is defined in the dictionary.

- (3) If the road is a two-way road, the driver must position the vehicle parallel, and as near as practicable, to the far left side of the road.

*Note* **Two-way road** is defined in the dictionary.

- (4) If the road is a one-way road, the driver must position the vehicle parallel, and as near as practicable, to the far left or far right side of the road, unless otherwise indicated by information on or with a parking control sign.

*Note* **One-way road**, **parking control sign** and **with** are defined in the dictionary.

- (5) If the driver does not park in a parking bay, the driver must position the vehicle at least 1 metre from the closest point of any vehicle in front of it and any vehicle behind it.

*Note* **Parking bay** is defined in the dictionary.

- (6) If the road has a continuous dividing line or a dividing strip, the driver must position the vehicle at least 3 metres from any dividing line or dividing strip, unless otherwise indicated by information on or with a parking control sign.

*Note* **Dividing line** and **dividing strip** are defined in the dictionary.

- (7) If the road does not have a continuous dividing line or a dividing strip, the driver must position the vehicle so there is at least 3 metres of the road alongside the vehicle that is clear for other vehicles to pass, unless otherwise indicated by information on or with a parking control sign.

- (8) The driver must position the vehicle so the vehicle does not unreasonably obstruct the path of other vehicles or pedestrians.

(9) This rule does not apply to:

- (a) a driver if the driver parks on a length of road, or in an area, to which a parking control sign or road marking applies, and information on or with the sign or road marking includes the words 'angle parking' or 'angle'; or
- (b) the rider of a motor bike if the rider parks the motor bike on a length of road, or in an area, to which a *permissive parking sign* applies and the sign indicates that the length of road or area is for parking motor bikes.

*Note 1* **Motor bike** and **road marking** are defined in the dictionary.

*Note 2* Division 9 deals with angle parking.

(10) Subrules (3) and (4) do not apply to the rider of a motor bike if the rider positions the motor bike so at least 1 wheel is as near as practicable to the far left or far right side of the road.

(11) If a road has one or more service roads, the part of the road used by the main body of moving vehicles, and each service road, is taken to be a separate road for this rule.

*Note* **Part of the road used by the main body of moving vehicles** and **service road** are defined in the dictionary.

(12) In this rule:

**continuous dividing line** means:

- (a) a single continuous dividing line only; or
- (b) a single continuous dividing line to the left or right of a broken dividing line; or
- (c) 2 parallel continuous dividing lines.

**road** does not include a road-related area, but includes any shoulder of the road.

*Note* **Road-related area** is defined in rule 13, and **shoulder** is defined in rule 12.

*Example*

Parallel parking — minimum distance from other vehicles and dividing strip

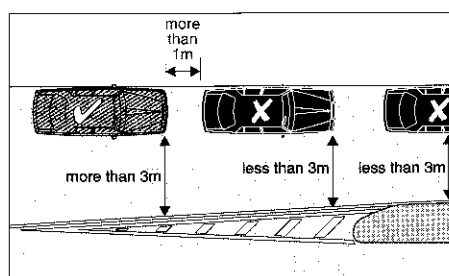

In the example, the vehicles marked with an 'X' are parked in contravention of this rule.

## 209 Parallel parking in a median strip parking area

- (1) This rule applies to a driver who parks in a median strip parking area if a parking control sign or road marking applies to the area, and information on or with the sign or road marking indicates that the driver's vehicle must be positioned parallel to the median strip.

*Note* **Driver's vehicle**, **median strip**, **median strip parking area**, **parking control sign**, **road marking** and **with** are defined in the dictionary.

**Rule 209**

---

- (2) The driver must position the driver's vehicle:
- (a) to face in the direction of travel of vehicles in the marked lane or line of traffic to the left of the driver; and
  - (b) parallel, and as near as practicable, to the centre of the median strip; and
  - (c) if the driver does not park in a parking bay — at least 1 metre from the closest point of any vehicle in front of it and any vehicle behind it.

Offence provision.

*Note* **Marked lane** and **parking bay** are defined in the dictionary.

- (3) This rule does not apply to the rider of a motor bike.

*Note* **Motor bike** is defined in the dictionary.

## Division 9 Angle parking

*Note 1* **Park** and **stop** are defined in the dictionary.

*Note 2* Rule 165 provides defences to the prosecution of a driver for an offence against a provision of this Division.

### 210 Angle parking

- (1) If a driver parks in a parking area on the side of a road, or in a median strip parking area, to which a parking control sign or road marking applies, and information on or with the sign or road marking includes the words 'angle parking' or 'angle', the driver must position the driver's vehicle in accordance with subrules (2) to (4).

Offence provision.

*Note 1* **Driver's vehicle**, **median strip parking area**, **parking area**, **parking control sign**, **road marking** and **with** are defined in the dictionary.

*Note 2* Rule 212 deals with whether a driver enters a median strip parking area forwards or in reverse.

- (2) If information on or with the parking control sign or road marking indicates that the vehicle must be positioned at an angle of 45°, or does not indicate another angle, the driver must position the driver's vehicle:
  - (a) so the vehicle is at an angle as near as practicable to 45°, as shown in example 1 or 2; and
  - (b) if the vehicle is parked on the side of the road — with the rear of the vehicle nearest to traffic in the marked lane or line of traffic next to the part of the road where the driver parks.

*Note* **Marked lane** is defined in the dictionary.

*Examples*

Example 1  
Parking at 45°  
at the side of a two-way road

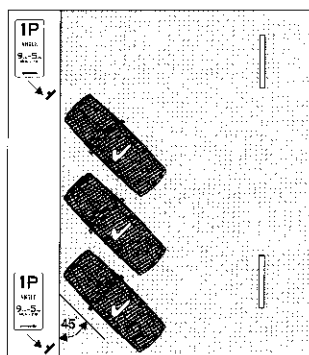

Example 2  
Parking at 45°  
at the right side of a one-way road

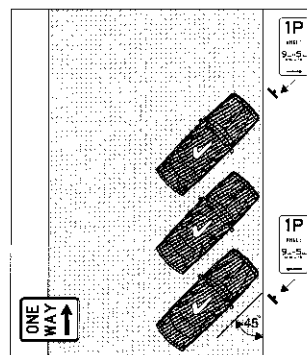

- (3) If information on or with the parking control sign or road marking indicates that the vehicle must be positioned at an angle of 90°, the driver:
  - (a) must position the driver's vehicle so the vehicle is at an angle as near as practicable to 90°, as shown in example 3 or 4; and

- (b) if the vehicle is parked on the side of the road — may position the vehicle with either the front or rear of the vehicle nearest to traffic in the marked lane or line of traffic next to the part of the road where the driver parks.

*Examples*

Example 3  
 Parking at 90°  
 at the side of a two-way road

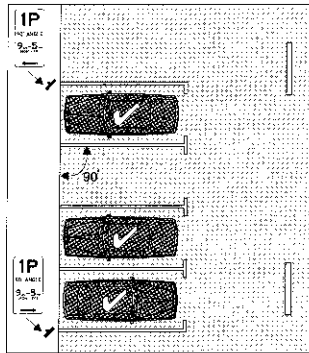

Example 4  
 Parking at 90°  
 at the right side of a one-way road

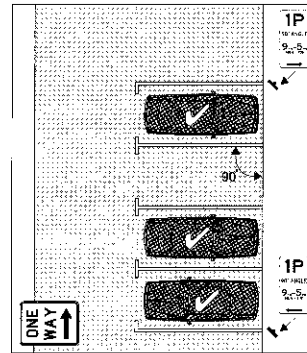

- (4) If information on or with the parking control sign or road marking indicates that the vehicle must be positioned at an angle of 135°, the driver must position the driver's vehicle:
- (a) so the vehicle is at an angle as near as practicable to 135°, as shown in example 5 or 6; and
  - (b) if the vehicle is parked on the side of the road — with the front of the vehicle nearest to traffic in the marked lane or line of traffic next to the part of the road where the driver parks.

*Examples*

Example 5  
 Parking at 135°  
 at the side of a road

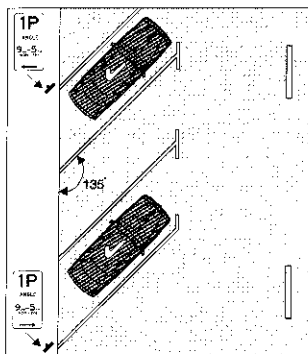

Example 6  
 Parking at 135°  
 in a median strip parking area

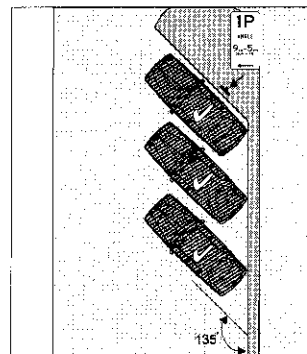

- (5) This rule does not apply to the rider of a motor bike.

*Note* **Motor bike** is defined in the dictionary.



## Division 10 Other parking related rules

*Note 1* **Area, length** of road, **park** and **stop** are defined in the dictionary.

*Note 2* Rule 165 provides defences to the prosecution of a driver for an offence against a provision of this Division.

### 211 Parking in parking bays

- (1) A driver must not park on a length of road, or in an area, to which a *park in bays only sign* applies, except in a parking bay.

Offence provision.

*Note* **Parking bay** is defined in the dictionary.

- (2) A driver who parks in a parking bay must position the driver's vehicle completely within the bay, unless the vehicle is too wide or long to fit completely within the bay.

Offence provision.

*Note 1* **Driver's vehicle** is defined in the dictionary.

*Note 2* **Vehicle** includes a combination — see rule 15 (d).

- (3) If the vehicle is too wide or long to fit completely within a single parking bay, the driver must park the driver's vehicle within the minimum number of parking bays needed to park the vehicle.

Offence provision.

Park in bays only sign



### 212 Entering and leaving a median strip parking area

- (1) If information on or with a traffic control device indicates that a driver must enter or leave a median strip parking area in a particular direction, the driver must enter or leave the area in that direction.

Offence provision.

*Note* **Median strip parking area, traffic control device** and **with** are defined in the dictionary.

**Rule 213**

---

- (2) If there is no information on or with a traffic control device that indicates that a driver must enter or leave a median strip parking area in a particular direction, the driver must enter or leave the area by driving forward.

Offence provision.

*Example*

Leaving median strip parking area by driving forward

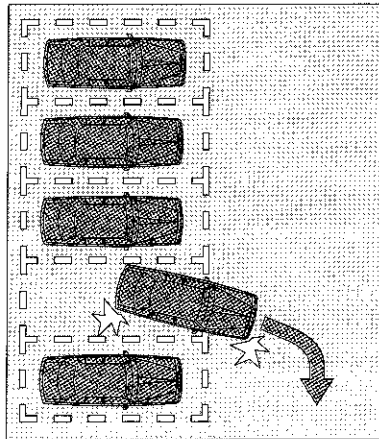

**213 Making a motor vehicle secure**

- (1) This rule applies to the driver of a motor vehicle who stops and leaves the vehicle on a road (except to pay a fee for parking the vehicle) so the driver is over 3 metres from the closest part of the vehicle if there is nobody 16 years old, or older, in the vehicle.

*Note* **Motor vehicle** is defined in the dictionary.

- (2) Before leaving the motor vehicle, the driver must comply with this rule, except so far as the driver is exempt from this rule under another law of this jurisdiction.

Offence provision.

- (3) The driver must:
- (a) switch off the engine; and
  - (b) apply the parking brake effectively or, if weather conditions (for example, snow) would prevent the effective operation of the parking brake, effectively restrain the motor vehicle's movement in another way.
- (4) If there is nobody in the motor vehicle, the driver must:
- (a) remove the ignition key; and
  - (b) if the doors of the vehicle can be locked — lock the doors.

## Part 13 Lights and warning devices

### Division 1 Lights on vehicles (except bicycles, animals and animal-drawn vehicles)

#### 214 Division does not apply to riders of bicycles, animals or animal-drawn vehicles

This Division does not apply to the rider of a bicycle, animal or animal-drawn vehicle.

*Note 1* **Bicycle** is defined in the dictionary.

*Note 2* The rules for using lights when riding a bicycle or an animal-drawn vehicle at night, or in hazardous weather conditions, are:

- for riders of bicycles — rule 259
- for riders of animal-drawn vehicles — rule 223.

#### 215 Using lights when driving at night or in hazardous weather conditions

- (1) A driver must not drive at night, or in hazardous weather conditions causing reduced visibility unless:
  - (a) the headlights, tail lights and number plate light fitted to the driver's vehicle are operating effectively and are clearly visible; and
  - (b) if the vehicle is fitted with clearance lights or side marker lights — those lights are operating effectively and are clearly visible.

Offence provision.

*Note 1* **Driver's vehicle** and **night** are defined in the dictionary.

*Note 2* **Drive** includes be in control of — see the definition in the dictionary.

- (2) However, this rule does not apply to a driver if the driver's vehicle is stopped or parked at a place on a length of road, or in an area, to which a parking control sign applies and the driver is permitted to stop or park at that place under the *Australian Road Rules*.

*Note* **Length** of road and **parking control sign** are defined in the dictionary.

- (3) Also, a driver driving during the day in fog, or other hazardous weather conditions causing reduced visibility, may drive without the headlights of the driver's vehicle operating if the vehicle is fitted with front fog lights and those lights are operating effectively and are clearly visible.
- (4) In subrule (1), a reference to a kind of **light** fitted to a vehicle is a reference to a light of that kind required to be fitted to the vehicle under another law of this jurisdiction.

#### 216 Towing a vehicle at night or in hazardous weather conditions

- (1) A driver must not tow a vehicle at night, or in hazardous weather conditions causing reduced visibility unless:
  - (a) if the towed vehicle is being towed from the front of the vehicle:
    - (i) the tail lights of the vehicle are operating effectively and are clearly visible; or
    - (ii) the vehicle has portable rear lights that are operating; or

**Rule 217**

---

- (b) if the towed vehicle is being towed from the rear of the vehicle — the vehicle has portable rear lights that are operating.

Offence provision.

*Note* **Night** is defined in the dictionary.

- (2) However, this rule does not apply to the driver of a tow truck if:
- (a) the driver is towing a disabled vehicle carrying a placard load of dangerous goods to a place that is safely off the road; and
  - (b) a vehicle carrying a warning to other traffic is following immediately behind the disabled vehicle.
- (3) In this rule:

**dangerous goods** has the meaning given, for the *Australian Road Rules*, under another law of this jurisdiction.

**placard load** has the meaning given, for the *Australian Road Rules*, under another law of this jurisdiction.

**portable rear lights** means:

- (a) for a vehicle being towed from the front of the vehicle — a pair of lights attached to the rear of the vehicle that, when operating, show a red light that is clearly visible for at least 200 metres from the rear of the vehicle; and
- (b) for a vehicle being towed from the rear of the vehicle — a pair of lights attached to the front of the vehicle that, when operating, show a red light that is clearly visible for at least 200 metres from the front of the vehicle.

**road** does not include a road-related area, but includes any shoulder of the road.

*Note* **Road-related area** is defined in rule 13, and **shoulder** is defined in rule 12.

## 217 Using rear fog lights

- (1) The driver of a vehicle fitted with a rear fog light must not operate the fog light unless the driver is driving in fog or other hazardous weather conditions causing reduced visibility.

Offence provision.

- (2) In this rule:

**rear fog light** means a light fitted to a vehicle to make it more easily visible from the rear in fog.

## 218 Using headlights on high-beam

- (1) The driver of a vehicle must not use the vehicle's headlights on high-beam, or allow the vehicle's headlights to be used on high-beam, if the driver is driving:
- (a) less than 200 metres behind a vehicle travelling in the same direction as the driver; or
  - (b) less than 200 metres from an oncoming vehicle.

Offence provision.

*Note* **High-beam** and **oncoming vehicle** are defined in the dictionary.

- (2) However, if the driver is overtaking a vehicle, the driver may briefly switch the headlights from low-beam to high-beam immediately before the driver begins to overtake the vehicle.

*Note* **Low-beam** and **overtake** are defined in the dictionary.

*Examples*

Example 1

Using headlights on low-beam when travelling less than 200 metres behind another vehicle travelling in the same direction

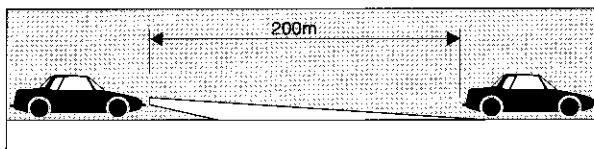

Example 2

Using headlights on low-beam when travelling within 200 metres of an oncoming vehicle

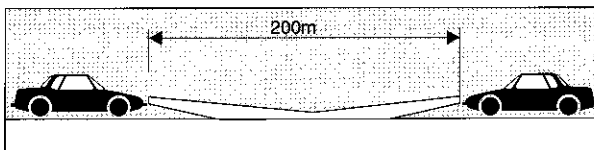

## 219 Lights not to be used to dazzle other road users

A driver must not use, or allow to be used, any light fitted to or in the driver's vehicle to dazzle, or in a way that is likely to dazzle, another road user.

Offence provision.

*Note 1* **Driver's vehicle** is defined in the dictionary, and **road user** is defined in rule 14.

*Note 2* **Driver** includes a person in control of a vehicle — see the definition of **drive** in the dictionary.

## 220 Using lights on vehicles that are stopped

- (1) A driver must not stop on a road at night unless:
- if the driver's vehicle is 2.2 metres wide, or wider — the clearance and side marker lights fitted to the vehicle are operating effectively and are clearly visible; or
  - in any other case — the parking lights fitted to the driver's vehicle are operating effectively and are clearly visible.

Offence provision.

*Note* **Driver's vehicle** and **night** are defined in the dictionary.

- (2) This rule does not apply to a driver if the driver stops on a length of road, or in an area, with street lighting and the driver's vehicle is visible for at least 200 metres in all directions from the vehicle.

*Note* **Length** of road is defined in the dictionary.

- (3) In subrule (1), a reference to a kind of **light** fitted to a vehicle is a reference to a light of that kind required to be fitted to the vehicle under another law of this jurisdiction.

**Rule 221**

---

(4) In this rule:

*road* does not include a road-related area, but includes any shoulder of the road.

*Note Road-related area* is defined in rule 13, and *shoulder* is defined in rule 12.

**221 Using hazard warning lights**

The driver of a vehicle fitted with hazard warning lights must not use the hazard warning lights, or allow them to be used, unless:

- (a) the vehicle is stopped and is obstructing, or is likely to obstruct, the path of other vehicles or pedestrians; or
- (b) the vehicle is a slow-moving vehicle and is obstructing, or is likely to obstruct, the path of other vehicles or pedestrians; or
- (c) the vehicle is stopped in an emergency stopping lane; or
- (d) the driver stops the vehicle to sell a product (for example, ice creams) that may attract children onto the road; or
- (e) the driver is driving in hazardous weather conditions (for example, fog or smoke); or
- (f) the vehicle is a bus carrying children, and the driver stops the vehicle to drop off or pick up a child and is required or permitted to operate the hazard warning lights under another law of this jurisdiction; or
- (g) the hazard warning lights are operating as part of an anti-theft device fitted to the vehicle.

Offence provision.

*Note 1 Bus* and *hazard warning lights* are defined in the dictionary, and *emergency stopping lane* is defined in rule 95.

*Note 2 Driver* includes a person in control of a vehicle — see the definition of *drive* in the dictionary.

*Note 3* A vehicle does not obstruct another vehicle only because the vehicle is stopped in traffic or is travelling more slowly than other vehicles — see the definition of *obstruction* in the dictionary.

**222 Using warning lights on buses carrying children**

- (1) This rule applies to the driver of a bus carrying children if the bus is required to be fitted with warning lights under another law of this jurisdiction.

*Note Bus* is defined in the dictionary.

- (2) The driver must not stop the bus to drop off or pick up a child unless the warning lights are operating as required under the law of this jurisdiction.

Offence provision.

## Division 2      Lights on animal-drawn vehicles

### 223 Using lights when riding an animal-drawn vehicle at night or in hazardous weather conditions

A person must not ride an animal-drawn vehicle at night, or in hazardous weather conditions causing reduced visibility, unless the vehicle is fitted with, and displays:

- (a) a white light fitted at or towards the front of each side of the vehicle that is clearly visible for at least 200 metres from the front of the vehicle; and
- (b) a red light fitted at or towards the rear of each side of the vehicle that is clearly visible for at least 200 metres from the rear of the vehicle; and
- (c) a red reflector fitted at or towards the rear of each side of the vehicle that is:
  - (i) not over 1.5 metres above ground level; and
  - (ii) clearly visible for at least 50 metres from the rear of the vehicle when light is projected onto it by another vehicle's headlight on low-beam.

Offence provision.

*Note* **Low-beam** and **night** are defined in the dictionary.

## **Division 3      Horns and radar detectors**

### **224   Using horns and similar warning devices**

A driver must not use, or allow to be used, a horn, or similar warning device, fitted to or in the driver's vehicle unless:

- (a) it is necessary to use the horn, or warning device, to warn other road users or animals of the approach or position of the vehicle; or
- (b) the horn, or warning device, is being used as part of an anti-theft device fitted to the vehicle.

Offence provision.

*Note 1* **Driver's vehicle** is defined in the dictionary, and **road user** is defined in rule 14.

*Note 2* **Driver** includes a person in control of a vehicle — see the definition of **drive** in the dictionary.

### **225   Using radar detectors and similar devices**

- (1) A person must not drive a vehicle if the vehicle has in or on it a device for preventing the effective use of a speed measuring device, or a device for detecting the use of a speed measuring device, unless the person is exempt from this rule under another law of this jurisdiction.

Offence provision.

*Note* **Drive** includes be in control of — see the definition in the dictionary.

- (2) Subrule (1) applies whether or not the device is operating or in working order.

*Note* Under the law of this jurisdiction, radar detectors and similar devices may be subject to confiscation.



## Division 4 Portable warning triangles for heavy vehicles

### 226 Heavy vehicles to be equipped with portable warning triangles

- (1) A person must not drive a vehicle with a GVM over 12 tonnes unless the vehicle is equipped with at least 3 portable warning triangles.

Offence provision.

*Note* **GVM** and **portable warning triangle** are defined in the dictionary.

- (2) The person must produce the portable warning triangles for inspection if the person is directed to do so by a police officer or an authorised person.

Offence provision.

*Note* **Authorised person** and **police officer** are defined in the dictionary.

### 227 Using portable warning triangles

- (1) This rule applies to a driver if the GVM of the driver's vehicle is over 12 tonnes.

*Note* **Driver's vehicle** and **GVM** are defined in the dictionary.

- (2) If the driver stops on a road and the vehicle is not visible at any time for at least 200 metres in all directions from the vehicle, the driver must use at least 3 portable warning triangles, positioned in accordance with subrule (4), to warn other road users of the vehicle.

Offence provision.

*Note 1* **Portable warning triangle** is defined in the dictionary, and **road user** is defined in rule 14.

*Note 2* See rule 220 for the requirement to operate certain lights on vehicles that are stopped.

- (3) If some or all of any load being carried by the vehicle falls onto a road and is not clearly visible at any time for at least 200 metres in all directions from the fallen load, the driver must use at least 3 portable warning triangles, positioned in accordance with subrule (4), to warn other road users of the fallen load.

Offence provision.

- (4) The driver must position the portable warning triangles so:
  - (a) 1 triangle is at least 50 metres, but not over 150 metres, in front of the vehicle or fallen load; and
  - (b) 1 triangle is at least 50 metres, but not over 150 metres, behind the vehicle or fallen load; and
  - (c) 1 triangle is at the side of the vehicle, or fallen load, in a position that gives sufficient warning to other road users of the position of the vehicle or fallen load.

- (5) In this rule:

**road** does not include a road-related area, but includes any shoulder of the road.

*Note* **Road-related area** is defined in rule 13, and **shoulder** is defined in rule 12.

***THIS PAGE INTENTIONALLY LEFT BLANK***

## Part 14 Rules for pedestrians

### Division 1 General

*Note 1* For the *Australian Road Rules*, a pedestrian includes:

- a person driving a motorised wheelchair that cannot travel at over 10 kilometres per hour (on level ground)
- a person in a non-motorised wheelchair
- a person pushing a motorised or non-motorised wheelchair
- a person in or on a wheeled recreational device or wheeled toy (see rule 18).

*Note 2* *Wheelchair*, *wheeled recreational device* and *wheeled toy* are defined in the dictionary.

#### 228 No pedestrians signs

A pedestrian must not travel past a *no pedestrians sign*.

Offence provision.

No pedestrians sign



#### 229 Pedestrians on a road with a road access sign

A pedestrian must not be on a length of road to which a *road access sign* applies if information on or with the sign indicates that pedestrians are not permitted beyond the sign.

Offence provision.

*Note 1* *Length* of road and *with* are defined in the dictionary.

*Note 2* For the way in which a *road access sign* applies, see rule 97. The sign is usually used on a freeway.

Road access sign



*Note 1 for diagram* There are a number of other permitted versions of the *road access sign* — see the diagrams in Schedule 3.

*Note 2 for diagram* The sign may indicate that it applies to different or additional vehicles or persons — see rule 316 (4).

### 230 Crossing a road — general

- (1) A pedestrian crossing a road:
  - (a) must cross by the shortest safe route; and
  - (b) must not stay on the road longer than necessary to cross the road safely.

Offence provision.

- (2) However, if the pedestrian is crossing the road at an intersection with traffic lights and a *pedestrians may cross diagonally sign*, the pedestrian may cross the road diagonally at the intersection.

*Note* **Intersection** and **traffic lights** are defined in the dictionary.

- (3) In this rule:

**road** does not include a road-related area, but includes any shoulder of the road.

*Note* **Road-related area** is defined in rule 13, and **shoulder** is defined in rule 12.

Pedestrians may cross diagonally sign

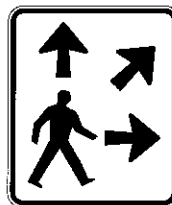

*Note for diagram* There is another permitted version of this sign — see the diagram in Schedule 3.

### 231 Crossing a road at pedestrian lights

- (1) A pedestrian approaching or at an intersection, or another place on a road, with pedestrian lights and traffic lights must comply with this rule.

Offence provision.

*Note* **Intersection**, **pedestrian lights** and **traffic lights** are defined in the dictionary.

- (2) If the pedestrian lights show a red pedestrian light and the pedestrian has not already started crossing the intersection or road, the pedestrian must not start to cross until the pedestrian lights change to green.

*Note 1* **Green pedestrian light** and **red pedestrian light** are defined in the dictionary.

*Note 2* A traffic control device (including pedestrian lights) generally only applies to a person if the device faces the person — see Part 20, Division 3, especially rule 340.

- (3) If, while the pedestrian is crossing the road, the pedestrian lights change to flashing red or red, the pedestrian must not stay on the road for longer than necessary to cross safely to the nearer (in the direction of travel of the pedestrian) of the following:
  - (a) a dividing strip, safety zone, or traffic island, forming part of the area set aside or used by pedestrians to cross the road at the intersection or place (the **safety area**);
  - (b) the nearest side of the road.

*Note* **Dividing strip** and **traffic island** are defined in the dictionary, and **safety zone** is defined in rule 162.

- (4) If, under subrule (3), the pedestrian crosses to the safety area, the pedestrian must remain in the safety area until the pedestrian lights change to green.
- (5) However, if the pedestrian cannot operate the pedestrian lights from the safety area, the pedestrian may cross to the far side of the road when:
- (a) the traffic lights change to green or flashing yellow, or there is no red traffic light showing; and
  - (b) it is safe to do so.

*Note* **Red traffic light** is defined in the dictionary.

- (6) In this rule:

**road** does not include a road-related area, but includes any shoulder of the road.

*Note* **Road-related area** is defined in rule 13, and **shoulder** is defined in rule 12.

Red pedestrian light showing  
red pedestrian symbol

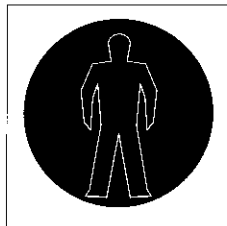

Green pedestrian light showing green  
pedestrian symbol

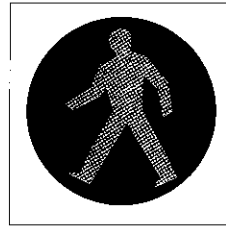

## 232 Crossing a road at traffic lights

- (1) A pedestrian approaching or at an intersection, or another place on a road, with traffic lights, but without pedestrian lights, must comply with this rule.

Offence provision.

*Note* **Intersection**, **pedestrian lights** and **traffic lights** are defined in the dictionary.

- (2) If the traffic lights show a red or yellow traffic light and the pedestrian has not already started crossing the intersection or road, the pedestrian must not start to cross until the traffic lights change to green or flashing yellow, or there is no red traffic light showing.

*Note* **Green traffic light**, **red traffic light** and **yellow traffic light** are defined in the dictionary.

- (3) If, while the pedestrian is crossing the road, the traffic lights change to yellow or red, the pedestrian must not stay on the road for longer than necessary to cross safely to the nearer (in the direction of travel of the pedestrian) of the following:

- (a) a dividing strip, safety zone, or traffic island, forming part of the area set aside or used by pedestrians to cross the road at the intersection or place (the **safety area**);
- (b) the nearest side of the road.

Offence provision.

*Note* **Dividing strip** and **traffic island** are defined in the dictionary, and **safety zone** is defined in rule 162.

**Rule 233**

---

- (4) If, under subrule (3), the pedestrian crosses to the safety area, the pedestrian must remain in the safety area until the traffic lights change to green or flashing yellow, or there is no red traffic light showing.

Offence provision.

- (5) In this rule:

**road** does not include a road-related area, but includes any shoulder of the road.

*Note* **Road-related area** is defined in rule 13, and **shoulder** is defined in rule 12.

**233 Crossing a road to or from a tram**

- (1) A pedestrian must not cross a road to get on a tram at a tram stop until the tram has stopped at the tram stop.

Offence provision.

*Note* **Tram** is defined in the dictionary.

- (2) A pedestrian crossing a road after getting off a tram:

- (a) must cross to the nearest footpath by the shortest safe route or, if there is no footpath, cross the road by the shortest safe route; and  
(b) must not stay on the road for longer than necessary to cross the road safely.

Offence provision.

*Note* **Footpath** is defined in the dictionary.

- (3) This rule does not apply to a pedestrian:

- (a) on a safety zone; or  
(b) crossing a road to or from a safety zone.

*Note* **Safety zone** is defined in rule 162.

- (4) Subrule (2) does not apply to:

- (a) a pedestrian in a shared zone; or  
(b) an employee of a public transport operator who is in uniform and engaged in carrying out his or her duties.

*Note* **Shared zone** is defined in rule 24.

- (5) In this rule:

**road** does not include a road-related area, but includes any shoulder of the road.

**tram** includes a bus travelling along tram tracks.

*Note 1* **Bus** and **travelling along tram tracks** are defined in the dictionary, **road-related area** is defined in rule 13, and **shoulder** is defined in rule 12.

*Note 2* For the duties of drivers where there are pedestrians getting on or off trams or buses, or in safety zones, see rules 162 to 164.

### 234 Crossing a road on or near a crossing for pedestrians

- (1) A pedestrian must not cross a road, or part of a road, within 20 metres of a crossing on the road, except at the crossing or another crossing, unless the pedestrian is:
  - (a) crossing, or helping another pedestrian to cross, an area of the road between tram tracks and the far left side of the road to get on, or after getting off, a tram or public bus; or
  - (b) crossing to or from a safety zone; or
  - (c) crossing at an intersection with traffic lights and a *pedestrians may cross diagonally sign*; or
  - (d) crossing in a shared zone; or
  - (e) crossing a road, or a part of a road, from which vehicles are excluded, either permanently or temporarily.

Offence provision.

*Note* **Intersection**, **public bus**, **traffic lights**, **tram** and **tram tracks** are defined in the dictionary, **safety zone** is defined in rule 162, and **shared zone** is defined in rule 24.

- (2) A pedestrian must not stay on a crossing on a road for longer than necessary to cross the road safely.

Offence provision.

- (3) Subrule (2) does not apply to a person who is helping pedestrians cross a road at a crossing if the person is permitted to do so under another law of this jurisdiction.

- (4) In this rule:

**crossing** means a children's crossing, marked foot crossing or pedestrian crossing.

*Note* **Children's crossing** is defined in rule 80, **marked foot crossing** is defined in the dictionary, and **pedestrian crossing** is defined in rule 81.

Pedestrians may cross diagonally sign

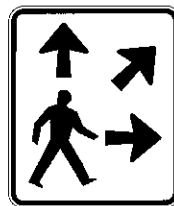

*Note for diagram* There is another permitted version of this sign — see the diagram in Schedule 3.

### 235 Crossing a level crossing

- (1) A pedestrian must not cross a railway line, or tram tracks, at a level crossing unless:
  - (a) there is a pedestrian facility at the crossing and the pedestrian uses the facility; or
  - (b) there is no pedestrian facility at, or within 20 metres of, the crossing.

Offence provision.

*Note* **Level crossing** is defined in rule 120.

- (2) A pedestrian must not cross a railway line, or tram tracks, at a level crossing if:
  - (a) warning lights (for example, twin red lights or rotating red lights) are flashing or warning bells are ringing; or

- (b) a gate, boom or barrier at the crossing is closed or is opening or closing; or
- (c) a train or tram is on or entering the crossing; or
- (d) a train or tram approaching the crossing can be seen from the crossing or is sounding a warning, and there would be a danger of the pedestrian being struck by the train or tram if the pedestrian entered the crossing; or
- (e) the crossing, or a road beyond the crossing, is blocked.

Offence provision.

*Example for paragraph (2) (e)*

The crossing, or a road beyond the crossing, may be blocked by congested traffic, a disabled vehicle, a collision between vehicles or between a vehicle and a pedestrian, or by stock on the road.

*Note* **Enter** and **twin red lights** are defined in the dictionary.

- (3) In this rule:

**pedestrian facility** means a footpath, bridge or other structure designed for the use of pedestrians.

*Note* **Footpath** is defined in the dictionary.

### **236 Pedestrians not to cause a traffic hazard or obstruction**

- (1) A pedestrian must not cause a traffic hazard by moving into the path of a driver.

Offence provision.

- (2) A pedestrian must not unreasonably obstruct the path of any driver or another pedestrian.

Offence provision.

- (3) For subrule (2), a pedestrian does not unreasonably obstruct the path of another pedestrian only by travelling more slowly than other pedestrians.

### **237 Getting on or into a moving vehicle**

- (1) A person must not get on, or into, a moving vehicle unless:

- (a) the person is engaged in the door-to-door delivery or collection of goods, or in the collection of waste or garbage, and is required to get in or out of the vehicle, or on or off the vehicle, at frequent intervals; and
- (b) the vehicle is not travelling at a speed over 5 kilometres per hour.

Offence provision.

- (2) This rule does not apply to a person who is getting on or off a bicycle or animal.

*Note 1* **Bicycle** is defined in the dictionary.

*Note 2* Rule 269 (1) prohibits a person getting off, or out of, a moving vehicle.



### **238 Pedestrians travelling along a road (except in or on a wheeled recreational device or toy)**

- (1) A pedestrian must not travel along a road if there is a footpath or nature strip adjacent to the road, unless it is impracticable to travel on the footpath or nature strip.

Offence provision.

*Note* **Footpath** and **nature strip** are defined in the dictionary.

- (2) A pedestrian travelling along a road:
- (a) must keep as far to the left or right side of the road as is practicable; and
  - (b) must not travel on the road alongside more than 1 other pedestrian or vehicle travelling on the road in the same direction as the pedestrian, unless the pedestrian is overtaking other pedestrians.

Offence provision.

- (3) In this rule:

**pedestrian** does not include a person travelling in or on a wheeled recreational device or wheeled toy.

**road** does not include a road-related area, but includes any shoulder of the road.

*Note 1* **Road-related area** is defined in rule 13, **shoulder** is defined in rule 12, and **wheeled recreational device** and **wheeled toy** are defined in the dictionary.

*Note 2* Persons travelling on roads in or on wheeled recreational devices or wheeled toys are dealt with in rule 241.

### **239 Pedestrians on a bicycle path or separated footpath**

- (1) A pedestrian must not be on a bicycle path, or a part of a separated footpath designated for the use of bicycles, unless the pedestrian:
- (a) is crossing the bicycle path or separated footpath by the shortest safe route; and
  - (b) does not stay on the bicycle path or separated footpath for longer than necessary to cross the bicycle path or separated footpath safely.

Offence provision.

*Note 1* **Bicycle** is defined in the dictionary, and **bicycle path** and **separated footpath** are defined in subrule (4).

*Note 2* Rule 336 deals with how parts of a separated footpath are designated for bicycle riders and pedestrians.

- (2) However, a pedestrian may be on a bicycle path, or a part of a separated footpath designated for the use of bicycles, if:
- (a) the pedestrian is:
    - (i) in or pushing a wheelchair; or
    - (ii) on rollerblades, rollerskates or a similar wheeled recreational device; and

- (b) there is no traffic control device, or information on or with a traffic control device, applying to the bicycle path or separated footpath that indicates that the pedestrian is not permitted to be on the bicycle path or the part of the separated footpath designated for the use of bicycles.

*Note 1* **Traffic control device**, **wheelchair**, **wheeled recreational device** and **with** are defined in the dictionary.

*Note 2* Rule 243 (2) provides that a person travelling on rollerblades, rollerskates, or a similar wheeled recreational device, on a bicycle path, or a part of a separated footpath designated for the use of bicycles, must keep out of the path of any bicycle.

- (3) A pedestrian who is crossing a bicycle path, or a part of a separated footpath designated for the use of bicycles, must keep out of the path of any bicycle, or any pedestrian who is permitted under subrule (2) to be on the bicycle path, or the part of the separated footpath designated for the use of bicycles.

Offence provision.

- (4) In the *Australian Road Rules*:

**bicycle path** means a length of path beginning at a *bicycle path sign* or bicycle path road marking, and ending at the nearest of the following:

- (a) an *end bicycle path sign* or end bicycle path road marking;
- (b) a *separated footpath sign* or separated footpath road marking;
- (c) a road (except a road-related area);
- (d) the end of the path.

*Note* **Road-related area** is defined in rule 13.

**bicycle path road marking** means a road marking on a path, consisting of a bicycle symbol, the words 'bicycles only', or both the bicycle symbol and the word 'only'.

*Note* **Bicycle symbol** is defined in the dictionary.

**end bicycle path road marking** means a bicycle path road marking with the word 'end'.

**end separated footpath road marking** means a separated footpath road marking with the word 'end'.

**separated footpath** means a length of footpath beginning at a *separated footpath sign* or separated footpath road marking, and ending at the nearest of the following:

- (a) an *end separated footpath sign* or end separated footpath road marking;
- (b) a *bicycle path sign* or bicycle path road marking;
- (c) a *no bicycles sign* or no bicycles road marking;
- (d) a road (except a road-related area);
- (e) the end of the footpath.

*Note* **Footpath** and **no bicycles road marking** are defined in the dictionary.

**separated footpath road marking** means a road marking on a footpath consisting of a pedestrian symbol and a bicycle symbol side by side, with or without the word 'only'.

*Note* **Pedestrian symbol** is defined in the dictionary.

Bicycle path sign



End bicycle path sign



Separated footpath sign



End separated footpath sign



No bicycles sign



*Note 1 for diagrams* There are a number of other permitted versions of the *bicycle path sign* and the *end bicycle path sign*, and another permitted version of each of the other signs — see the diagrams in Schedule 3.

*Note 2 for diagrams* A *separated footpath sign* may have the pedestrian symbol and the bicycle symbol reversed — see rule 316 (4).

## **Division 2 Rules for persons travelling in or on wheeled recreational devices and wheeled toys**

*Note 1* For the *Australian Road Rules*, a person in or on a wheeled recreational device or wheeled toy is a pedestrian, not a rider — see rule 18 (d). This Division contains rules that apply only to persons travelling in or on wheeled recreational devices and wheeled toys.

*Note 2* *Wheeled recreational device* and *wheeled toy* are defined in the dictionary.

### **240 Wheeled recreational devices and toys not to be used on certain roads**

- (1) A person must not travel in or on a wheeled recreational device or wheeled toy on a road with a dividing line or median strip, or on a one-way road with more than 1 marked lane.

Offence provision.

*Note* *Dividing line*, *marked lane*, *median strip* and *one-way road* are defined in the dictionary.

- (2) A person must not travel in or on a wheeled recreational device:
- (a) on a road that is declared, under another law of this jurisdiction, to be a road on which wheeled recreational devices are prohibited; or
  - (b) on a road at a particular time if another law of this jurisdiction prohibits wheeled recreational devices from being on all roads, or that road, at that time.

Offence provision.

*Example for paragraph (b)*

Another law of this jurisdiction may provide that a person must not travel in or on a wheeled recreational device on a road at night.

- (3) A person must not travel in or on a wheeled toy:
- (a) on a road that is declared, under another law of this jurisdiction, to be a road on which wheeled toys are prohibited; or
  - (b) on a road at a particular time if another law of this jurisdiction prohibits wheeled toys on all roads, or that road, at that time.

Offence provision.

- (4) In subrule (1), *road* does not include a road-related area but includes any shoulder of the road.

### **241 Travelling in or on a wheeled recreational device or toy on a road**

- (1) A person travelling in or on a wheeled recreational device or wheeled toy on a road:
- (a) must keep as far to the left side of the road as is practicable; and
  - (b) must not travel alongside more than 1 other pedestrian or vehicle travelling on the road in the same direction as the person, unless the person is overtaking other pedestrians.

Offence provision.

- (2) In this rule:

*road* does not include a road-related area, but, in subrule (1) (b), includes any shoulder of the road.

*Note* *Road-related area* is defined in rule 13, and *shoulder* is defined in rule 12.

## 242 Travelling in or on a wheeled recreational device or toy on a footpath or shared path

- (1) A person travelling in or on a wheeled recreational device or wheeled toy on a footpath or shared path must:
- (a) keep to the left of the footpath or shared path unless it is impracticable to do so; and
  - (b) give way to any pedestrian (except a person travelling in or on a wheeled recreational device or wheeled toy) who is on the footpath or shared path.

Offence provision.

*Note 1* **Footpath** is defined in the dictionary.

*Note 2* For this rule, **give way** means the person must slow down and, if necessary, stop to avoid a collision — see the definition in the dictionary.

*Note 3* Bicycle riders on footpaths and shared paths must give way to persons travelling in or on wheeled recreational devices or toys, as well as other pedestrians — see rule 250 (2).

*Note 4* Another law of this jurisdiction may prescribe give way rules for persons travelling in or on wheeled recreational devices or toys.

- (2) A **shared path** is an area open to the public (except a separated footpath) that is designated for, or has as one of its main uses, use by both the riders of bicycles and pedestrians, and includes a length of path for use by both bicycles and pedestrians beginning at a **shared path sign** and ending at the nearest of the following:
- (a) an **end shared path sign**;
  - (b) a **no bicycles sign** or no bicycles road marking;
  - (c) a **bicycle path sign**;
  - (d) a road (except a road-related area);
  - (e) the end of the path.

*Note* **Bicycle** and **no bicycles road marking** are defined in the dictionary, **road-related area** is defined in rule 13, and **separated footpath** is defined in rule 239.

Shared path sign



End shared path sign



No bicycles sign



Bicycle path sign



*Note for diagrams* There are a number of other permitted versions of the **bicycle path sign**, and another permitted version of each of the other signs — see the diagrams in Schedule 3.

**Rule 243**

---

**243 Travelling on rollerblades etc on a bicycle path or separated footpath**

- (1) A person travelling on rollerblades, rollerskates, or a similar wheeled recreational device, must not be on a part of a separated footpath designated for the use of pedestrians unless the person:
- (a) is crossing the separated footpath by the shortest safe route; and
  - (b) does not stay on the separated footpath for longer than necessary to cross the separated footpath safely.

Offence provision.

*Note* **Separated footpath** is defined in rule 239.

- (2) A person travelling on rollerblades, rollerskates, or a similar wheeled recreational device, on a bicycle path, or a part of a separated footpath designated for the use of bicycles, must keep out of the path of any bicycle.

Offence provision.

*Note* **Bicycle** is defined in the dictionary, and **bicycle path** is defined in rule 239.

**244 Holding onto a moving vehicle**

A person travelling in or on a wheeled recreational device or wheeled toy must not hold onto a vehicle while the vehicle is moving.

Offence provision.

*Note* **Vehicle** is defined in rule 15.

## Part 15 Additional rules for bicycle riders

*Note 1* This Part contains rules that apply only to bicycle riders. Most rules in the *Australian Road Rules* apply to bicycle riders in the same way as they apply to drivers — see rule 19. There are some other rules that are for bicycle riders only, or that have exceptions for bicycle riders. These include:

- optional hook turn by bicycle riders — rule 35
- bicycle riders making a hook turn contrary to a *no hook turn by bicycles sign* — rule 36
- bicycle riders excepted from giving stop signals — rule 52
- exception for bicycle riders riding in emergency stopping lanes — rule 95
- bicycle riders entering and leaving roundabouts — rules 111 and 119
- bicycle riders overtaking on the left — rule 141
- riding alongside other riders — rule 151
- bicycle lanes — rule 153
- parking at a bicycle rail or in a bicycle rack — rule 166
- stopping on footpaths — rule 197
- stopping on a road with a *bicycle parking sign* — rule 201.

*Note 2* **Bicycle** is defined in the dictionary.

### 245 Riding a bicycle

The rider of a bicycle must:

- (a) sit astride the rider's seat facing forwards (except if the bicycle is not built to be ridden astride); and
- (b) ride with at least 1 hand on the handlebars; and
- (c) if the bicycle is equipped with a seat — not ride the bicycle seated in any other position on the bicycle.

Offence provision.

### 246 Carrying people on a bicycle

The rider of a bicycle must not carry more persons on the bicycle than the bicycle is designed to carry.

Offence provision.

### 247 Riding in a bicycle lane on a road

- (1) The rider of a bicycle riding on a length of road with a bicycle lane designed for bicycles travelling in the same direction as the rider must ride in the bicycle lane unless it is impracticable to do so.

Offence provision.

*Note* Rule 153 defines a **bicycle lane** and deals with the use of bicycle lanes by other vehicles.

## Rule 248

---

- (2) In this rule:

**road** does not include a road-related area.

*Note* **Road-related area** includes the shoulder of a road — see rule 13.

### 248 No riding across a road on a crossing

The rider of a bicycle must not ride across a road, or part of a road, on a children's crossing, marked foot crossing or pedestrian crossing.

Offence provision.

*Note* **Children's crossing** is defined in rule 80, **marked foot crossing** is defined in the dictionary, and **pedestrian crossing** is defined in rule 81.

### 249 Riding on a separated footpath

The rider of a bicycle must not ride on a part of a separated footpath designated for the use of pedestrians.

Offence provision.

*Note 1* **Separated footpath** is defined in rule 239, and **pedestrian** is defined in rule 18.

*Note 2* Rule 336 deals with how parts of a separated footpath are designated for bicycle riders and pedestrians.

### 250 Riding on a footpath or shared path

- (1) The rider of a bicycle who is 12 years old or older must not ride on a footpath if another law of this jurisdiction prohibits the rider from riding on the footpath.

Offence provision.

*Example of another law of this jurisdiction*

Another law of this jurisdiction may provide that a commercial courier must not ride a bicycle on any footpath or any footpath in a particular area, or that an adult must not ride a bicycle on a footpath unless the adult is accompanying a child under 12 years who is also riding on the footpath.

*Note* **Footpath** is defined in the dictionary.

- (2) The rider of a bicycle riding on a footpath or shared path must:
- keep to the left of the footpath or shared path unless it is impracticable to do so; and
  - give way to any pedestrian on the footpath or shared path.

Offence provision.

*Note 1* **Pedestrian** is defined in rule 18, and **shared path** is defined in rule 242.

*Note 2* For subrule (2), **give way** means the rider must slow down and, if necessary, stop to avoid a collision — see the definition in the dictionary.

- (3) In this rule:

**footpath** does not include a separated footpath.

*Note* **Separated footpath** is defined in rule 239.



## Rule 252

**251 Riding to the left of oncoming bicycle riders on a path**

The rider of a bicycle riding on a bicycle path, footpath, separated footpath or shared path must keep to the left of any oncoming bicycle rider on the path.

Offence provision.

*Note* **Bicycle path** and **separated footpath** are defined in rule 239, **footpath** is defined in the dictionary, and **shared path** is defined in rule 242.

**252 No bicycles signs and markings**

- (1) The rider of a bicycle must not ride on a length of road or footpath to which a *no bicycles sign*, or a *no bicycles road marking*, applies.

Offence provision.

*Note* **Footpath**, **length** of road and **no bicycles road marking** are defined in the dictionary.

- (2) A *no bicycles sign*, or a *no bicycles road marking*, applies to a length of road or footpath beginning at the sign or marking and ending at the nearest of the following:
- a *bicycle path sign* or bicycle path road marking;
  - a *bicycle lane sign*;
  - a *separated footpath sign* or separated footpath road marking;
  - a *shared path sign*;
  - an *end no bicycles sign*;
  - the next intersection.

*Note* **Intersection** is defined in the dictionary, and **bicycle path road marking** and **separated footpath road marking** are defined in rule 239.

No bicycles sign



Bicycle path sign



Bicycle lane sign



Separated footpath sign



**Rule 253**

Shared path sign



End no bicycles sign



*Note 1 for diagrams* There are a number of other permitted versions of the *bicycle path sign* and *bicycle lane sign*, and another permitted version of the *no bicycles sign*, *separated footpath sign* and *shared path sign* — see the diagrams in Schedule 3.

*Note 2 for diagrams* A *separated footpath sign* may have the pedestrian symbol and the bicycle symbol reversed — see rule 316 (4).

**253 Bicycle riders not to cause a traffic hazard**

The rider of a bicycle must not cause a traffic hazard by moving into the path of a driver or pedestrian.

Offence provision.

**254 Bicycles being towed etc**

- (1) A person must not ride on a bicycle that is being towed by another vehicle.

Offence provision.

*Note* **Vehicle** is defined in rule 15.

- (2) The rider of a bicycle must not hold onto another vehicle while the vehicle is moving.

Offence provision.

**255 Riding too close to the rear of a motor vehicle**

The rider of a bicycle must not ride within 2 metres of the rear of a moving motor vehicle continuously for more than 200 metres.

Offence provision.

*Note* **Motor vehicle** is defined in the dictionary.

**256 Bicycle helmets**

- (1) The rider of a bicycle must wear an approved bicycle helmet securely fitted and fastened on the rider's head, unless the rider is exempt from wearing a bicycle helmet under another law of this jurisdiction.

Offence provision.

*Note* **Approved bicycle helmet** is defined in the dictionary.

- (2) The rider of a bicycle must not carry a passenger on the bicycle unless:
- (a) the passenger is wearing an approved bicycle helmet securely fitted and fastened on the passenger's head; or

**Rule 259**

- (b) the passenger is exempt from wearing a bicycle helmet under another law of this jurisdiction.

Offence provision.

- (3) Subrule (2) does not apply to the rider of a three or four-wheeled bicycle who is carrying a paying passenger.

**257 Riding with a person on a bicycle trailer**

- (1) The rider of a bicycle must not tow a bicycle trailer with a person in or on the bicycle trailer, unless:
- (a) the rider is 16 years old, or older; and
  - (b) the person in or on the bicycle trailer is under 10 years old, or as otherwise provided under another law of this jurisdiction; and
  - (c) the bicycle trailer can safely carry the person; and
  - (d) the person in or on the bicycle trailer is wearing an approved bicycle helmet securely fitted and fastened on the person's head, unless the person is exempt from wearing a bicycle helmet under another law of this jurisdiction.

Offence provision.

*Note* **Approved bicycle helmet** is defined in the dictionary.

- (2) In this rule:

**bicycle trailer** means a vehicle that is built to be towed, or is towed, by a bicycle.

*Note* **Vehicle** is defined in rule 15.

**258 Equipment on a bicycle**

A person must not ride a bicycle that does not have:

- (a) at least 1 effective brake; and
- (b) a bell, horn, or similar warning device, in working order.

Offence provision.

**259 Riding at night**

The rider of a bicycle must not ride at night, or in hazardous weather conditions causing reduced visibility, unless the bicycle, or the rider, displays:

- (a) a flashing or steady white light that is clearly visible for at least 200 metres from the front of the bicycle; and
- (b) a flashing or steady red light that is clearly visible for at least 200 metres from the rear of the bicycle; and
- (c) a red reflector that is clearly visible for at least 50 metres from the rear of the bicycle when light is projected onto it by a vehicle's headlight on low-beam.

Offence provision.

*Note* **Low-beam** and **night** are defined in the dictionary.

**Rule 260**

**260 Stopping for a red bicycle crossing light**

- (1) The rider of a bicycle approaching or at bicycle crossing lights showing a red bicycle crossing light must stop before reaching the bicycle crossing lights.

Offence provision.

*Note* **Bicycle crossing lights** and **red bicycle crossing light** are defined in the dictionary.

- (2) The rider must not proceed until:
  - (a) the bicycle crossing lights change to green; or
  - (b) there is no red bicycle crossing light showing.

Offence provision.

*Note* **Green bicycle crossing light** is defined in the dictionary.

*Example*

Red bicycle crossing light



Green bicycle crossing light



**261 Stopping for a yellow bicycle crossing light**

- (1) The rider of a bicycle approaching bicycle crossing lights showing a yellow bicycle crossing light must comply with this rule.

Offence provision.

*Note* **Bicycle crossing lights** and **yellow bicycle crossing light** are defined in the dictionary.

- (2) If the rider can stop safely before reaching the bicycle crossing lights, the bicycle rider must stop before reaching the lights.
- (3) If the rider stops before reaching the bicycle crossing lights, and the lights change to red, the bicycle rider must not proceed until:
  - (a) the bicycle crossing lights change to green; or
  - (b) there is no red or yellow bicycle crossing light showing.

*Note* **Green bicycle crossing light** and **red bicycle crossing light** are defined in the dictionary.

Yellow bicycle crossing light



**262 Proceeding when bicycle crossing lights change to yellow or red**

- (1) If bicycle crossing lights at an intersection change from green to yellow or red while the rider of a bicycle is in the intersection, the rider must finish crossing the intersection as soon as the rider can do so safely.

Offence provision.

*Note 1* **Bicycle crossing lights** is defined in the dictionary.

*Note 2* **Intersection** does not include a road-related area — see the definition in the dictionary.

- (2) If bicycle crossing lights at a place on a road where the rider of a bicycle is crossing the road change from green to yellow or red while the rider is on the road, the rider must cross the road as soon as the rider can do so safely.

Offence provision.

- (3) In this rule:

**road** does not include a road-related area.

*Note* **Road-related area** includes the shoulder of a road — see rule 13.

***THIS PAGE INTENTIONALLY LEFT BLANK***

## Part 16 Rules for persons travelling in or on vehicles

### 263 Application of Part to persons in or on trams

This Part, except rule 269 (1), does not apply to a person in or on a tram.

*Note* Rule 269 (1) prohibits a person getting off, or out of, a moving vehicle.

### 264 Wearing of seatbelts by drivers

- (1) The driver of a motor vehicle that is moving, or is stationary but not parked, must comply with this rule if the driver's seating position is fitted with a seatbelt.

Offence provision.

*Note* **Driver** is defined in rule 16, and **motor vehicle** and **park** are defined in the dictionary.

- (2) The driver must wear the seatbelt properly adjusted and fastened unless the driver is:
  - (a) reversing the vehicle; or
  - (b) exempt from wearing a seatbelt under rule 267.

*Note* Rule 267 provides exemptions from wearing seatbelts.

### 265 Wearing of seatbelts by passengers 16 years old, or older

- (1) A passenger in or on a motor vehicle that is moving, or is stationary but not parked, must comply with this rule if the passenger is 16 years old, or older.

Offence provision.

*Note* **Motor vehicle** and **park** are defined in the dictionary.

- (2) The passenger must occupy a seating position fitted with a seatbelt if:
  - (a) there is a seating position fitted with a seatbelt that is not already occupied by someone else who is not exempt from wearing a seatbelt; and
  - (b) the passenger is not exempt from wearing a seatbelt under rule 267.
- (3) If the passenger occupies a seating position fitted with a seatbelt, the passenger must wear the seatbelt properly adjusted and fastened unless the passenger is exempt from wearing a seatbelt under rule 267.
- (4) If the motor vehicle has 2 or more rows of seats, the passenger must not sit in the front row of seats unless:
  - (a) the passenger is occupying a seating position fitted with a seatbelt; or
  - (b) there is not a seating position available for the passenger in another row of seats; or
  - (c) the passenger is permitted to sit in the front row of seats under another law of this jurisdiction.

*Note* Another law of this jurisdiction may prohibit the carrying of passengers for whom seatbelts are not available.

**Rule 266**

---

**266 Wearing of seatbelts by passengers under 16 years old**

- (1) The driver of a motor vehicle (except a bus or motor bike) that is moving, or is stationary but not parked, must ensure that this rule is complied with for each passenger in or on the vehicle who is under 16 years old.

Offence provision.

*Note* **Bus**, **motor bike**, **motor vehicle** and **park** are defined in the dictionary.

- (2) If the passenger is under 1 year old, and not exempt from wearing a seatbelt under rule 267, the passenger must be restrained in a suitable approved child restraint that is properly fastened and adjusted, unless the driver is exempt from this subrule under subrule (5).

*Note* **Approved child restraint** is defined in subrule (7).

- (3) If the passenger is at least 1 year old but under 16 years old, and not exempt from wearing a seatbelt under rule 267, the passenger must be restrained in a suitable approved child restraint that is properly fastened and adjusted, or occupy a seating position fitted with a suitable seatbelt and wear the seatbelt properly adjusted and fastened, if:

- (a) a suitable approved child restraint, or a seating position fitted with a suitable seatbelt, is available in the motor vehicle for the passenger; or
- (b) another law of this jurisdiction requires all passengers at least 1 year old but under 16 years old to be restrained in an approved child restraint, or wear a seatbelt, unless they are exempt from wearing a seatbelt under the law of this jurisdiction.

- (4) If the motor vehicle has 2 or more rows of seats, the passenger must not be in the front row of seats unless the passenger is restrained in a suitable approved child restraint or occupying a seating position fitted with a seatbelt.

*Note* Another law of this jurisdiction may prohibit the carrying of passengers for whom approved child restraints or seatbelts are not available.

- (5) The driver of a public minibus or taxi is exempt from subrule (2) in relation to a passenger if:
- (a) there is no suitable approved child restraint available in the minibus or taxi for the passenger; and
  - (b) if the minibus or taxi has 2 or more rows of seats — the passenger is not in the front row of seats; and
  - (c) there is not another law of this jurisdiction requiring all passengers in a minibus or taxi who are under 1 year old to be restrained in an approved child restraint.

*Note* **Public minibus** and **taxi** are defined in the dictionary.

- (6) For this rule:
- (a) an approved child restraint is available in the motor vehicle for a passenger if an approved child restraint is fitted in the vehicle and is not occupied by someone else under 16 years old; and
  - (b) a seating position (whether or not fitted with a seatbelt) is available in the vehicle for a passenger if it is not occupied by someone else under 16 years old; and
  - (c) an approved child restraint or seatbelt is suitable for a passenger if it is suitable for restraining, or to be worn by the passenger.

- (7) In this rule:

**approved child restraint** means a child restraint approved, for the *Australian Road Rules*, under another law of this jurisdiction.



**Rule 267****267 Exemptions from wearing seatbelts**

- (1) A person is exempt from wearing a seatbelt if:
  - (a) the person is exempt from wearing a seatbelt under another law of this jurisdiction and is complying with the conditions (if any) of the exemption; and
  - (b) if the person is a passenger in a motor vehicle with 2 or more rows of seats and there is not another law of this jurisdiction permitting the person to sit in the front row of seats — the person is not in the front row of seats.

*Note* **Motor vehicle** is defined in the dictionary.

- (2) A person in or on a motor vehicle is exempt from wearing a seatbelt if:
  - (a) the person is engaged in the door-to-door delivery or collection of goods, or in the collection of waste or garbage, and is required to get in or out of the vehicle, or on or off the vehicle, at frequent intervals; and
  - (b) the vehicle is not travelling over 25 kilometres per hour.
- (3) A person is exempt from wearing a seatbelt if:
  - (a) the person (or, for a passenger, the driver of the vehicle in which the person is a passenger) is carrying a certificate, issued under another law of this jurisdiction, stating that the person is not required to wear a seatbelt; and
  - (b) the person is complying with the conditions (if any) stated in the certificate.

- (4) However, a person is not exempt under subrule (3) from wearing a seatbelt if the person (or, for a passenger, the driver of the vehicle in which the person is a passenger) does not immediately produce the certificate mentioned in the subrule for inspection when a police officer or authorised person asks the person (or the driver) whether the person is exempt from wearing a seatbelt.

*Note* **Authorised person** and **police officer** are defined in the dictionary.

- (5) A person is exempt from wearing a seatbelt if:
  - (a) the person is a passenger in a police or emergency vehicle; and
  - (b) if the vehicle has 2 or more rows of seats — the person is not in the front row of seats or there is not a seating position available for the person in another row of seats.

*Note* **Emergency vehicle** and **police vehicle** are defined in the dictionary.

**268 How persons must travel in or on a motor vehicle**

- (1) A person must not travel in or on a part of a motor vehicle that is not a part designed primarily for the carriage of passengers or goods.

Offence provision.

*Note* **Motor vehicle** is defined in the dictionary.

- (2) A person must not travel in or on a part of a motor vehicle that is a part designed primarily for the carriage of goods if the part is:
  - (a) not enclosed; or
  - (b) declared under another law of this jurisdiction to be a part of the vehicle in or on which persons must not be carried.

Offence provision.

*Note* **Enclosed** is defined in subrule (7).

**Rule 269**

---

- (3) A person must not travel in or on a motor vehicle with any part of the person's body outside a window or door of the vehicle, unless the person is the driver of the vehicle and is giving a hand signal:

- (a) for changing direction to the right in accordance with rule 50; or
- (b) for stopping or slowing in accordance with rule 55.

Offence provision.

- (4) The driver of a motor vehicle (except a bus) must not drive with a passenger if any part of the passenger's body is outside a window or door of the vehicle.

Offence provision.

*Note* **Bus** is defined in the dictionary.

- (5) This rule does not apply to a person who is:

- (a) in or on a police or emergency vehicle; or
- (b) on a motor bike; or
- (c) engaged in the door-to-door delivery or collection of goods, or in the collection of waste or garbage, in or on a motor vehicle that is not travelling over 25 kilometres per hour.

*Note* **Emergency vehicle**, **motor bike**, and **police vehicle** are defined in the dictionary.

- (6) This rule also does not apply to a person if:

- (a) the person is exempt from this rule under another law of this jurisdiction and is complying with the conditions (if any) of the exemption; or
- (b) the vehicle is exempt from this rule under another law of this jurisdiction.

- (7) For this rule:

**enclosed**, for a part of a vehicle, means enclosed by:

- (a) the structure of the vehicle; or
- (b) a canopy, cage or other device fitted to the vehicle that is approved, for the *Australian Road Rules*, under another law of this jurisdiction.

**269 Opening doors and getting out of a vehicle etc**

- (1) A person must not get off, or out of, a moving vehicle, unless the person is engaged in the door-to-door delivery or collection of goods, or in the collection of waste or garbage, and the vehicle is not travelling over 5 kilometres per hour.

Offence provision.

*Note 1* **Vehicle** is defined in rule 15.

*Note 2* Rule 237 deals with persons getting on, or into, a moving vehicle.

- (2) Subrule (1) does not apply to a person getting off a bicycle or animal.

- (3) A person must not cause a hazard to any person or vehicle by opening a door of a vehicle, leaving a door of a vehicle open, or getting off, or out of, a vehicle.

Offence provision.

**Rule 270**

- (4) The driver of a bus must not drive the bus unless the doors of the bus are closed while the bus is moving.

Offence provision.

*Note* **Bus** is defined in the dictionary.

**270 Wearing motor bike helmets**

- (1) The rider of a motor bike that is moving, or is stationary but not parked, must:
- (a) wear an approved motor bike helmet securely fitted and fastened on the rider's head; and
  - (b) not ride with a passenger unless the passenger complies with subrule (2).

Offence provision.

*Note* **Motor bike** and **park** are defined in the dictionary.

- (2) A passenger on a motor bike that is moving, or is stationary but not parked, must wear an approved motor bike helmet securely fitted and fastened on the passenger's head.

Offence provision.

- (3) In this rule:

**approved motor bike helmet** means a protective helmet for motor bike riders that is approved, for the *Australian Road Rules*, under another law of this jurisdiction.

**passenger**, of a motor bike, includes a person on the pillion seat of the motor bike, or in a sidecar.

**271 Riding on motor bikes**

- (1) The rider of a motor bike that is moving, or is stationary but not parked, must:
- (a) sit astride the rider's seat facing forwards; and
  - (b) ride with at least 1 hand on the handlebars; and
  - (c) if the motor bike is moving — keep both feet on the footrests designed for use by the rider of the motor bike.

Offence provision.

*Note* **Motor bike** and **park** are defined in the dictionary.

- (2) A passenger on a motor bike (except a passenger in a sidecar) that is moving, or is stationary but not parked, must:

- (a) sit astride the pillion seat facing forwards; and
- (b) keep both feet on the footrests designed for use by a pillion passenger on the motor bike.

Offence provision.

- (3) The rider of a motor bike must not ride with a passenger (except a passenger in a sidecar) unless the passenger complies with subrule (2).

Offence provision.

- (4) The rider of a motor bike must not ride with more than 1 passenger (excluding any passenger in a sidecar).

Offence provision.

**Rule 272**

---

- (5) The rider of a motor bike must not ride with more passengers in a side car than the sidecar is designed to carry.

Offence provision.

- (6) A provision of this rule does not apply to a person if the person is exempt from the provision under another law of this jurisdiction.

**272 Interfering with the driver's control of the vehicle etc**

A passenger in or on a vehicle must not:

- (a) interfere with the driver's control of the vehicle; or  
(b) obstruct the driver's view of the road or traffic.

Offence provision.

## Part 17 Additional rules for drivers of trams and public buses

*Note 1* This Part contains rules about T lights and B lights. These are traffic signals that operate in the same way as, or together with, traffic lights but apply only to drivers of trams, public buses and, in the case of B lights, to other vehicles if specified by another law of this jurisdiction. An example of a T light is shown in rule 278 and an example of a B light is shown in rule 285.

*Note 2* Rule 309 sets out a number of exemptions from the *Australian Road Rules* for drivers of trams and public buses travelling along tram tracks. Some other rules have exceptions for drivers of trams or particular trams.

### Division 1 Trams

*Note* *Public bus*, *T lights*, *tram* and *travelling along tram tracks* are defined in the dictionary.

#### 273 Division also applies to public buses travelling along tram tracks

This Division applies to the driver of a public bus travelling along tram tracks as if a reference in the Division to a tram included a reference to a public bus travelling along tram tracks.

#### 274 Stopping for a red T light

The driver of a tram approaching or at T lights showing a red T light must stop:

- (a) if there is a stop line at or near the T lights — as near as practicable to, but before reaching, the stop line; or
- (b) if there is no stop line at or near the T lights — as near as practicable to, but before reaching, the nearest or only T lights.

Offence provision.

*Note 1* *Red T light* and *stop line* are defined in the dictionary.

*Note 2* Rule 276 explains when the driver of a tram does not have to stop for a red T light.

#### 275 Stopping for a yellow T light

The driver of a tram approaching or at T lights showing a yellow T light must stop:

- (a) if there is a stop line at or near the T lights and the driver can stop safely before reaching the stop line — as near as practicable to, but before reaching, the stop line; or
- (b) if there is no stop line at or near the T lights and the driver can stop safely before reaching the T lights — as near as practicable to, but before reaching, the nearest or only T lights.

Offence provision.

*Note 1* *Yellow T light* and *stop line* are defined in the dictionary.

*Note 2* Rule 276 explains when the driver of a tram does not have to stop for a yellow T light.

### **276 Exception to stopping for a red or yellow T light**

The driver of a tram approaching or at T lights showing a red or yellow T light does not have to stop if a white traffic arrow is also showing and the driver is turning in the direction indicated by the arrow.

*Note* **Red T light**, **white traffic arrow** and **yellow T light** are defined in the dictionary.

### **277 Proceeding after stopping for a red or yellow T light**

The driver of a tram who stops for T lights showing a red or yellow T light must not proceed until:

- (a) a white T light is showing; or
- (b) no T light is showing and traffic lights at or near the T lights are showing a green traffic light.

Offence provision.

*Note* **Green traffic light**, **red T light**, **traffic lights**, **white T light** and **yellow T light** are defined in the dictionary. A diagram of a white T light is shown in rule 278.

### **278 Proceeding when a red traffic light and a white T light or white traffic arrow is showing**

- (1) The driver of a tram approaching or at a white T light at or near traffic lights showing a red traffic light may proceed straight ahead, or turn, despite the red traffic light.

*Note* **Red traffic light**, **straight ahead**, **traffic lights** and **white T light** are defined in the dictionary.

- (2) The driver of a tram approaching or at a white traffic arrow at or near traffic lights showing a red traffic light may turn in the direction indicated by the arrow, despite the red traffic light.

*Note* **White traffic arrow** is defined in the dictionary.

White T light

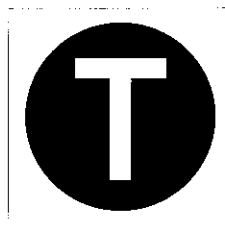

### **279 Proceeding when a white T light or white traffic arrow is no longer showing**

- (1) This rule applies to:
  - (a) the driver of a tram at an intersection with T lights showing a white T light who has stopped after the stop line, or nearest or only T lights, at the intersection; or

- (b) the driver of a tram at an intersection with traffic arrows showing a white traffic arrow who is turning in the direction indicated by the arrow and has stopped after the stop line, or nearest or only traffic arrows, at the intersection.

*Example*

The driver of a tram may stop after the stop line at an intersection with T lights showing a white T light, and not proceed through the intersection, because the intersection, or a road beyond the intersection, is blocked by traffic.

*Note* **Intersection**, **stop line**, **traffic arrows**, **white T light** and **white traffic arrow** are defined in the dictionary.

- (2) If the T lights or traffic arrows change to yellow or red, or turn off, while the driver is stopped and the driver has not entered the intersection, the driver must not proceed until:
- (a) a white T light is showing; or
  - (b) there is no T light showing, and traffic lights at or near the T lights are showing a green traffic light; or
  - (c) if the driver is turning at the intersection — a white traffic arrow is showing that indicates the direction in which the driver is turning.

Offence provision.

*Note* **Enter**, **green traffic light**, **red traffic arrow** and **yellow traffic arrow** are defined in the dictionary.

- (3) If the T lights or traffic arrows change to yellow or red, or turn off, while the driver is stopped and the driver has entered the intersection, the driver must leave the intersection as soon as the driver can do so safely.

Offence provision.

## **Division 2 Public buses**

*Note* **B lights** and **public bus** are defined in the dictionary.

### **280 Division does not apply to public buses travelling along tram tracks**

- (1) This Division does not apply to the driver of a public bus travelling along tram tracks.

*Note* The rules in Division 1 of this Part apply to drivers of public buses travelling along tram tracks — see rule 273.

- (2) This Division applies to the driver of a vehicle other than a public bus, in the same way as it applies to the driver of a public bus, if:
- (a) the vehicle being driven by the driver is in a class of vehicles specified for this rule by another law of this jurisdiction; and
  - (b) the driver is driving in a bus lane to which B lights apply; and
  - (c) the driver is permitted to drive in the lane under another law of this jurisdiction.

### **281 Stopping for a red B light**

The driver of a public bus approaching or at B lights showing a red B light must stop:

- (a) if there is a stop line at or near the B lights — as near as practicable to, but before reaching, the stop line; or
- (b) if there is no stop line at or near the B lights — as near as practicable to, but before reaching, the nearest or only B lights.

Offence provision.

*Note 1* **Red B light** and **stop line** are defined in the dictionary.

*Note 2* Rule 283 explains when the driver of a public bus does not have to stop for a red B light.

### **282 Stopping for a yellow B light**

The driver of a public bus approaching or at B lights showing a yellow B light must stop:

- (a) if there is a stop line at or near the B lights and the driver can stop safely before reaching the stop line — as near as practicable to, but before reaching, the stop line; or
- (b) if there is no stop line at or near the B lights and the driver can stop safely before reaching the B lights — as near as practicable to, but before reaching, the nearest or only B lights.

Offence provision.

*Note 1* **Yellow B light** and **stop line** are defined in the dictionary.

*Note 2* Rule 283 explains when the driver of a public bus does not have to stop for a yellow B light.

### **283 Exception to stopping for a red or yellow B light**

The driver of a public bus approaching or at B lights showing a red or yellow B light does not have to stop if a white traffic arrow is also showing and the driver is turning in the direction indicated by the arrow.

*Note* **Red B light**, **white traffic arrow** and **yellow B light** are defined in the dictionary.



## 284 Proceeding after stopping for a red or yellow B light

The driver of a public bus who stops for B lights showing a red or yellow B light must not proceed until:

- (a) a white B light is showing; or
- (b) no B light is showing and traffic lights at or near the B lights are showing a green traffic light.

Offence provision.

*Note* **Green traffic light**, **red B light**, **traffic lights**, **white B light** and **yellow B light** are defined in the dictionary. A diagram of a white B light is shown in rule 285.

## 285 Proceeding when a red traffic light and a white B light or white traffic arrow is showing

- (1) The driver of a public bus approaching or at a white B light at or near traffic lights showing a red traffic light may proceed straight ahead, or turn, despite the red traffic light.

*Note* **Red traffic light**, **straight ahead**, **traffic lights** and **white B light** are defined in the dictionary.

- (2) The driver of a public bus approaching or at a white traffic arrow at or near traffic lights showing a red traffic light may turn in the direction indicated by the arrow, despite the red traffic light.

*Note* **White traffic arrow** is defined in the dictionary.

White B light

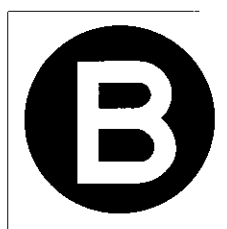

## 286 Proceeding when a white B light or white traffic arrow is no longer showing

- (1) This rule applies to:
  - (a) the driver of a public bus at an intersection with B lights showing a white B light who has stopped after the stop line, or nearest or only B lights, at the intersection; or
  - (b) the driver of a public bus at an intersection with traffic arrows showing a white traffic arrow who is turning in the direction indicated by the arrow and has stopped after the stop line, or nearest or only traffic arrows, at the intersection.

### *Example*

The driver of a public bus may stop after the stop line at an intersection with B lights showing a white B light, and not proceed through the intersection, because the intersection, or a road beyond the intersection, is blocked by traffic.

*Note* **Intersection**, **stop line**, **traffic arrows**, **white B light** and **white traffic arrow** are defined in the dictionary.

**Rule 286**

---

- (2) If the B lights or traffic arrows change to yellow or red, or turn off, while the driver is stopped and the driver has not entered the intersection, the driver must not proceed until:
- (a) a white B light is showing; or
  - (b) there is no B light showing, and traffic lights at or near the B lights are showing a green traffic light; or
  - (c) if the driver is turning at the intersection — a white traffic arrow is showing that indicates the direction in which the driver is turning.

Offence provision.

*Note* **Enter**, **green traffic light**, **red traffic arrow** and **yellow traffic arrow** are defined in the dictionary.

- (3) If the B lights or traffic arrows change to yellow or red, or turn off, while the driver is stopped and the driver has entered the intersection, the driver must leave the intersection as soon as the driver can do so safely.

Offence provision.

## Part 18 Miscellaneous road rules

### Division 1 Miscellaneous rules for drivers

#### 287 Duties of a driver involved in a crash

- (1) A driver involved in a crash must comply with this rule.

Offence provision.

*Note 1* **Crash** is defined in the dictionary.

*Note 2* The law of this jurisdiction also requires a driver involved in a crash to stop and give assistance to anyone who is injured.

- (2) The driver (or the driver's representative) must give the driver's required particulars, within the required time and, if practicable, at the scene of the crash, to:
- (a) any other driver (or that driver's representative) involved in the crash; and
  - (b) any other person involved in the crash who is injured, or the person's representative; and
  - (c) the owner of any property (including any vehicle) damaged in the crash (or the owner's representative), unless, in the case of damage to a vehicle, the particulars are given to the driver of the vehicle (or the driver's representative).
- (3) The driver (or the driver's representative) must also give the driver's required particulars, within the required time, to a police officer if:
- (a) anyone is killed or injured in the crash; or
  - (b) the driver does not, for any reason, give the driver's required particulars to each person mentioned in subrule (2); or
  - (c) the required particulars for any other driver involved in the crash are not given to the driver; or
  - (d) a vehicle involved in the crash is towed or carried away by another vehicle (except if another law of this jurisdiction provides that the crash is not required to be reported); or
  - (e) the crash is required to be reported to a police officer under another law of this jurisdiction.

*Note* **Police officer** is defined in the dictionary.

- (4) For this rule:

**required particulars**, for a driver involved in a crash, means:

- (a) the driver's name and address; and
- (b) the name and address of the owner of the driver's vehicle; and
- (c) the vehicle's registration number (if any); and
- (d) any other information necessary to identify the vehicle;

and, for subrule (3), includes any other information required to be given to a police officer about the crash under another law of this jurisdiction.

*Note* **Driver's vehicle** is defined in the dictionary.

**required time**, for a driver involved in a crash, means as soon as possible but, except in exceptional circumstances, within 24 hours after the crash.

## **288 Driving on a path**

- (1) A driver (except the rider of a bicycle) must not drive on a path, unless subrule (2) or (3) applies to the driver.

Offence provision.

*Note* **Bicycle** is defined in the dictionary, and **path** is defined in subrule (6).

- (2) A driver may drive on a path if the driver is:
- (a) driving on a part of the path indicated by information on or with a traffic control device as a part where vehicles may drive; or
  - (b) driving on the path to enter or leave, by the shortest practicable route, a road-related area or adjacent land and there is not a part of the path indicated by information on or with a traffic control device as a part where vehicles may drive; or
  - (c) permitted to drive on the path under another law of this jurisdiction.

*Note* **Adjacent land**, **traffic control device** and **with** are defined in the dictionary, and **road-related area** is defined in rule 13.

- (3) A driver may drive a motorised wheelchair on a path if:
- (a) the unladen mass of the wheelchair is not over 110 kilograms; and
  - (b) the wheelchair is not travelling over 10 kilometres per hour; and
  - (c) because of the driver's physical condition, the driver has a reasonable need to use a wheelchair.

*Note* **Wheelchair** is defined in the dictionary.

- (4) A driver on a path (except the rider of a bicycle, or a driver driving on the path to enter a road from a road-related area or adjacent land, or to enter a road-related area or adjacent land from a road) must give way to all other road users, and to animals, on the path.

Offence provision.

*Note 1* **Road user** is defined in rule 14.

*Note 2* For this subrule, **give way** means the driver must slow down and, if necessary, stop to avoid a collision — see the definition in the dictionary.

*Note 3* Rules 74 and 75 deal with drivers giving way when crossing a footpath or other path to enter or leave a road-related area or adjacent land.

*Note 4* Rules 249 to 251 deal with bicycle riders riding on footpaths, separated paths and shared paths.

- (5) This rule does not apply to the rider of an animal riding the animal on a footpath.

*Note 1* **Footpath** is defined in the dictionary.

*Note 2* The rider of an animal on a footpath must give way to a pedestrian on the path — see rule 302.

- (6) In this rule:

**path** means a bicycle path, footpath or shared path.

*Note* **Bicycle path** is defined in rule 239, **footpath** is defined in the dictionary and **shared path** is defined in rule 242.

## 289 Driving on a nature strip

- (1) A driver must not drive on a nature strip adjacent to a length of road in a built-up area, unless the driver is:
- (a) entering or leaving, by the shortest practicable route, an area on the nature strip indicated by information on or with a traffic control device as an area where vehicles may drive; or
  - (b) driving on a part of the nature strip indicated by information on or with a traffic control device as a part where vehicles may drive; or
  - (c) driving on the nature strip to enter or leave, by the shortest practicable route, a road-related area or adjacent land and there is not a part of the nature strip indicated by information on or with a traffic control device as a part where vehicles may drive; or
  - (d) riding a bicycle or animal, and there is not another law of this jurisdiction prohibiting the rider from riding a bicycle or animal on the nature strip; or
  - (e) driving a ride-on lawnmower that is cutting grass on the nature strip; or
  - (f) driving a motorised wheelchair; or
  - (g) permitted to drive on the nature strip under another law of this jurisdiction.

Offence provision.

*Note* **Adjacent land**, **bicycle**, **built-up area**, **length** of road, **nature strip**, **traffic control device**, **wheelchair** and **with** are defined in the dictionary, and **road-related area** is defined in rule 13.

- (2) A driver driving on a nature strip (except the rider of an animal, or a driver driving on the nature strip to enter a road from a road-related area or adjacent land, or to enter a road-related area or adjacent land from a road) must give way to all other road users, and to animals, on the nature strip.

Offence provision.

*Note 1* **Road user** is defined in the dictionary.

*Note 2* For subrule (2), **give way** means the driver must slow down and, if necessary, stop to avoid a collision — see the definition in the dictionary.

*Note 3* Rules 74 and 75 deal with drivers giving way when crossing a nature strip adjacent to a road to enter or leave a road-related area or adjacent land.

*Note 4* The rider of an animal on a nature strip must give way to any pedestrian on the nature strip — see rule 302.

## 290 Driving on a traffic island

A driver must not drive on a traffic island (except the central traffic island in a roundabout), unless:

- (a) the traffic island is designed to allow vehicles to be driven on it; or
- (b) the driver is permitted to drive on the traffic island under another law of this jurisdiction.

Offence provision.

*Note 1* **Roundabout** is defined in rule 109, and **traffic island** is defined in the dictionary.

*Note 2* A driver must drive to the left of the central traffic island in a roundabout except in certain circumstances — see rule 115.

### **291 Making unnecessary noise or smoke**

A person must not start a vehicle, or drive a vehicle, in a way that makes unnecessary noise or smoke.

Offence provision.

*Example*

Causing the wheels of the driver's vehicle to lose traction and spin on the road surface may make unnecessary noise or smoke.

*Note* Other laws of this jurisdiction also deal with vehicles and equipment that make noise or smoke.

### **292 Insecure or overhanging load**

A driver must not drive or tow a vehicle if the vehicle is carrying a load that:

- (a) is not properly secured to the vehicle; or
- (b) is placed on the vehicle in a way that causes the vehicle to be unstable; or
- (c) projects from the vehicle in a way that is likely to injure a person, obstruct the path of other drivers or pedestrians, or damage a vehicle or anything else (for example, the road surface).

Offence provision.

*Note* Other laws of this jurisdiction may deal with the loading of vehicles and carrying loads on vehicles.

### **293 Removing fallen etc things from the road**

(1) This rule applies to a driver if:

- (a) something falls onto the road from the driver's vehicle, or the driver, or a passenger in or on the driver's vehicle, puts something on the road; and
- (b) there is a possibility that the thing, if left on the road, may injure a person, obstruct the path of other drivers or pedestrians, or damage a vehicle or anything else (for example, the road surface).

*Note* **Driver's vehicle** is defined in the dictionary.

(2) The driver must remove the thing, or take action to have the thing removed, from the road as soon as the driver can do so safely.

Offence provision.

*Examples of things*

- 1 Fallen loads.
- 2 Oil or grease.
- 3 Debris from an accident.
- 4 Wheel chocks.

*Note* Rule 165 (e) provides a defence to the prosecution of a driver for an offence against a provision of Part 12 (Restrictions on stopping and parking) if the driver stops to comply with another provision of the *Australian Road Rules* (including this rule).

(3) In this rule:

**put**, something onto the road, includes:

- (a) throw, drop or propel the thing onto the road; and
- (b) otherwise cause the thing to be on the road.

## **294 Keeping control of a vehicle being towed**

- (1) The driver of a motor vehicle must not tow another motor vehicle unless:
  - (a) either:
    - (i) the driver can control the movement of the towed vehicle; or
    - (ii) the brakes and steering of the towed vehicle are in working order and a person who is licensed to drive the towed vehicle is sitting in the driver's seat of the towed vehicle, and is in control of its brakes and steering; and
  - (b) it is safe to tow the towed vehicle.

Offence provision.

*Note* **Motor vehicle** is defined in the dictionary.

- (2) The driver of a motor vehicle must not tow a trailer unless:
  - (a) the driver can control the movement of the trailer; and
  - (b) it is safe to tow the trailer.

Offence provision.

*Note* **Trailer** is defined in the dictionary.

## **295 Motor vehicle towing another vehicle with a towline**

- (1) The driver of a motor vehicle towing another vehicle using a chain, rope, fabric, strap or wire (the **towline**) must comply with this rule.

Offence provision.

*Note* **Motor vehicle** is defined in the dictionary, and **vehicle** is defined in rule 15.

- (2) If neither of the vehicles is a motor bike, the driver must keep a distance of not over 4 metres between the vehicles.

*Note* **Motor bike** is defined in the dictionary.
- (3) If at least 1 of the vehicles is a motor bike, the driver must keep a distance of not over 2.5 metres between the vehicles.
- (4) If the towline is longer than 2 metres, the driver must attach a white or brightly coloured flag, piece of cloth or other similar material (the **warning material**) to the towline in accordance with subrule (5).
- (5) The warning material must:
  - (a) be substantially square or rectangular with 2 adjacent sides at least 300 millimetres long; and
  - (b) be attached midway along the towline; and
  - (c) be visible for at least 100 metres from either side of the warning material.
- (6) Subrule (2), (3) or (4) does not apply to a driver if the driver is exempt from the subrule under another law of this jurisdiction and is complying with the conditions (if any) of the exemption.

### **296 Driving a vehicle in reverse**

- (1) The driver of a vehicle must not reverse the vehicle unless the driver can do so safely.

Offence provision.

- (2) The driver of a vehicle must not reverse the vehicle further than is reasonable in the circumstances.

Offence provision.

### **297 Driver to have proper control of a vehicle etc**

- (1) A driver must not drive a vehicle unless the driver has proper control of the vehicle.

Offence provision.

- (2) A driver must not drive a motor vehicle unless the driver has a clear view of the road, and traffic, ahead, behind and to each side of the driver.

Offence provision.

*Note* **Motor vehicle** is defined in the dictionary.

### **298 Driving with a person in a trailer**

A driver must not drive a motor vehicle towing a trailer with a person in or on the trailer, unless the trailer is exempt from this rule under another law of this jurisdiction.

Offence provision.

*Note 1* **Motor vehicle** and **trailer** are defined in the dictionary.

*Note 2* Rule 257 deals with persons travelling in or on bicycle trailers.

### **299 Television receivers and visual display units in motor vehicles**

- (1) A driver must not drive a motor vehicle that has a television receiver or visual display unit in or on the vehicle operating while the vehicle is moving, or is stationary but not parked, if any part of the image on the screen:

- (a) is visible to the driver from the normal driving position; or  
(b) is likely to distract another driver.

Offence provision.

*Note* **Motor vehicle** and **park** are defined in the dictionary, and **vehicle** is defined in rule 15.



- (2) This rule does not apply to the driver if:
- (a) the driver is driving a bus and the visual display unit is, or displays, a destination sign or other bus sign; or
  - (b) the visual display unit is, or is part of, a driver's aid; or
  - (c) the driver or vehicle is exempt from this rule under another law of this jurisdiction.

*Examples of driver's aids*

- 1 Closed-circuit television security cameras.
- 2 Dispatch systems.
- 3 Navigational or intelligent highway and vehicle system equipment.
- 4 Rearview screens.
- 5 Ticket-issuing machines.
- 6 Vehicle monitoring devices.

*Note* **Bus** is defined in the dictionary.

### **300 Use of hand-held mobile phones**

- (1) The driver of a vehicle (except an emergency vehicle or police vehicle) must not use a hand-held mobile phone while the vehicle is moving, or is stationary but not parked, unless the driver is exempt from this rule under another law of this jurisdiction.

Offence provision.

*Note* **Emergency vehicle, park** and **police vehicle** are defined in the dictionary.

- (2) In this rule:  
**mobile phone** does not include a CB radio or any other two-way radio.

## **Division 2      Rules for people in charge of animals**

### **301    Leading an animal while driving a vehicle**

A person must not lead an animal while driving a motor vehicle or riding a bicycle, unless the person is permitted to do so under another law of this jurisdiction.

Offence provision.

*Note* **Bicycle** and **motor vehicle** are defined in the dictionary.

### **302    Rider of an animal on a footpath or nature strip to give way to pedestrians**

The rider of an animal must give way to any pedestrian on a footpath or nature strip.

Offence provision.

*Note 1* **Footpath** and **nature strip** are defined in the dictionary, and **pedestrian** is defined in rule 18.

*Note 2* For this rule, **give way** means the rider must slow down and, if necessary, stop to avoid a collision — see the definition in the dictionary.

### **303    Riding an animal alongside more than 1 other rider**

- (1) The rider of an animal must not ride on a road that is not a multi-lane road alongside more than 1 other rider, unless subrule (3) applies to the rider.

Offence provision.

*Note* **Multi-lane road** is defined in the dictionary, and **rider** is defined in rule 17.

- (2) The rider of an animal must not ride in a marked lane alongside more than 1 other rider in the marked lane, unless subrule (3) applies to the rider.

Offence provision.

*Note* **Marked lane** is defined in the dictionary.

- (3) The rider of an animal may ride alongside more than 1 other rider if the rider is:

- (a) overtaking the other riders or droving stock; or
- (b) permitted to do so under another law of this jurisdiction.

*Note* **Overtake** is defined in the dictionary.

- (4) If the rider of an animal is riding on a road that is not a multi-lane road alongside another rider, or in a marked lane alongside another rider in the marked lane, the rider must ride not over 1.5 metres from the other rider.

Offence provision.

- (5) In this rule:

**road** does not include a road-related area, but includes a bicycle path, shared path and any shoulder of the road.

*Note* **Bicycle path** is defined in rule 239, **road-related area** is defined in rule 13, **shared path** is defined in rule 242, and **shoulder** is defined in rule 12.

---

## Division 3      Obeying directions

### 304    Direction by a police officer or authorised person

- (1) A person must obey any reasonable direction for the safe and efficient regulation of traffic given to the person by a police officer or authorised person, whether or not the person may contravene another provision of the *Australian Road Rules* by obeying the direction.

Offence provision.

*Note* **Authorised person** and **police officer** are defined in the dictionary.

- (2) It is a defence to the prosecution of a person for an offence against a provision of the *Australian Road Rules* if, at the time of the offence, the person was obeying a direction given to the person under subrule (1).

***THIS PAGE INTENTIONALLY LEFT BLANK***

## Part 19 Exemptions

### 305 Exemption for drivers of police vehicles

- (1) A provision of the *Australian Road Rules* does not apply to the driver of a police vehicle if:
  - (a) in the circumstances:
    - (i) the driver is taking reasonable care; and
    - (ii) it is reasonable that the provision should not apply; and
  - (b) if the vehicle is a motor vehicle that is moving — the vehicle is displaying a blue or red flashing light or sounding an alarm.

*Note* **Motor vehicle** and **police vehicle** are defined in the dictionary.

- (2) Subrule (1) (b) does not apply to the driver if, in the circumstances, it is reasonable:
  - (a) not to display the light or sound the alarm; or
  - (b) for the vehicle not to be fitted or equipped with a blue or red flashing light or an alarm.

### 306 Exemption for drivers of emergency vehicles

A provision of the *Australian Road Rules* does not apply to the driver of an emergency vehicle if:

- (a) in the circumstances:
  - (i) the driver is taking reasonable care; and
  - (ii) it is reasonable that the rule should not apply; and
- (b) if the vehicle is a motor vehicle that is moving — the vehicle is displaying a blue or red flashing light or sounding an alarm.

*Note* **Emergency vehicle** and **motor vehicle** are defined in the dictionary.

### 307 Stopping and parking exemption for police and emergency vehicles and authorised persons

- (1) A provision of Part 12 does not apply to the driver of a police vehicle or emergency vehicle if, in the circumstances:
  - (a) the driver is taking reasonable care; and
  - (b) it is reasonable that the provision should not apply.

*Note 1* **Emergency vehicle** and **police vehicle** are defined in the dictionary.

*Note 2* Part 12 deals with restrictions on stopping and parking.

- (2) A provision of Part 12 does not apply to a driver who is an authorised person driving a vehicle in the course of his or her duty as an authorised person if, in the circumstances:
  - (a) the driver is taking reasonable care; and
  - (b) it is reasonable that the provision should not apply.

*Note* **Authorised person** is defined in the dictionary.

**Rule 308**

---

**308 Exemption for police officers and emergency workers on foot**

A provision in Part 14 does not apply to a police officer or emergency worker acting in the course of his or her duty if, in the circumstances:

- (a) the police officer or emergency worker is taking reasonable care; and
- (b) it is reasonable that the provision should not apply.

*Note 1* **Emergency worker** and **police officer** are defined in the dictionary.

*Note 2* Part 14 provides rules for pedestrians.

**309 Exemption for drivers of trams etc**

The following provisions do not apply to the driver of a tram, or a public bus travelling along tram tracks:

- Part 4 (Making turns), Division 1 (Left turns at intersections)
- rule 88 (Left turn signs)
- rule 89 (Right turn signs)
- rule 90 (No turns signs)
- rule 91 (No left turn and no right turn signs)
- rule 92 (Traffic lane arrows)
- rule 99 (Keep left and keep right signs)
- rule 100 (No entry signs)
- Part 9 (Roundabouts)
- Part 11 (Keeping left, overtaking and other driving rules), Divisions 2 (Keeping to the left), 3 (Overtaking), and 7 (Passing trams and safety zones)
- Part 12 (Restrictions on stopping and parking).

*Note* **Public bus**, **tram** and **travelling along tram tracks** are defined in the dictionary.

**310 Exemption for road workers etc**

(1) A provision mentioned in subrule (2) does not apply to a person at the site of, and engaged in, roadworks if, in the circumstances:

- (a) it is not practicable for the person to comply with the provision; and
- (b) sufficient warning of the roadworks has been given to other road users.

*Note* **Roadworks** is defined in subrule (4).

(2) Subrule (1) applies to the following provisions:

- Part 4 (Making turns), Division 1 (Left turns at intersections) and Division 2 (Right turns (except hook turns) at intersections)
- Part 7 (Giving way), except:
  - rule 67 (Stopping and giving way at a *stop sign* or stop line at an intersection without traffic lights)
  - rule 68 (Stopping and giving way at a *stop sign* or stop line at other places)
  - rule 69 (Giving way at a *give way sign* or give way line at an intersection)
  - rule 70 (Giving way at a *give way sign* at a bridge or length of narrow road)
  - rule 71 (Giving way at a *give way sign* or give way line at other places)

**Rule 311**

- Part 8 (Traffic signs and road markings), except:
    - rule 102 (Clearance and low clearance signs)
    - rule 103 (Load limit signs)
  - Part 11 (Keeping left, overtaking and other driving rules)
  - Part 12 (Restrictions on stopping and parking)
  - rule 224 (Using horns and similar warning devices)
  - Part 14 (Rules for pedestrians), except rule 236 (1) (which is about causing a traffic hazard by moving into the path of an approaching vehicle)
  - rule 264 (Wearing of seatbelts by drivers)
  - rule 265 (Wearing of seatbelts by passengers 16 years old, or older)
  - rule 268 (How persons must travel in or on a motor vehicle)
  - rule 288 (Driving on a path)
  - rule 289 (Driving on a nature strip)
  - rule 290 (Driving on a traffic island)
  - rule 295 (Motor vehicle towing another vehicle with a towline)
  - rule 296 (Driving a vehicle in reverse)
  - rule 297 (2) (which requires a driver to have a clear view of the surrounding road and traffic)
  - rule 298 (Driving with a person in a trailer).
- (3) Rule 20 (Obeying the speed-limit) does not apply to a driver:
- (a) driving a snow-clearing vehicle and engaged in snow-clearing; or
  - (b) driving a motor vehicle and engaged in speed zoning tests authorised under another law of this jurisdiction.
- (4) In this rule:
- roadworks* means:
- (a) construction or maintenance of a road; or
  - (b) road cleaning; or
  - (c) installation or maintenance work authorised under another law of this jurisdiction on, above or below a road; or
  - (d) installation or maintenance of a traffic control device, traffic-related item or traffic monitoring device; or
  - (e) a traffic survey authorised under another law of this jurisdiction; or
  - (f) a road surface survey test.

*Note 1* *Traffic control device* and *traffic-related item* are defined in the dictionary.

*Note 2* A person may need to be authorised under another law of this jurisdiction to carry out roadworks or tests mentioned in this rule.

**311 Exemption for oversize vehicles**

- (1) A provision mentioned in subrule (2) does not apply to the driver of an oversize vehicle, or the driver of a vehicle escorting or piloting an oversize vehicle, if:
- (a) it is not practicable for the driver to comply with the provision; and
  - (b) the driver is taking reasonable care; and

**Rule 312**

---

- (c) the driver is complying with any other relevant law of this jurisdiction relating to oversized vehicles, including the conditions of any permit or authority issued in relation to the oversized vehicle.

*Note* **Oversize vehicle** is defined in the dictionary.

- (2) For subrule (1), the provisions are as follows:

- Part 7 (Giving way), except:
  - rule 67 (Stopping and giving way at a *stop sign* or stop line at an intersection without traffic lights)
  - rule 68 (Stopping and giving way at a *stop sign* or stop line at other places)
  - rule 69 (Giving way at a *give way sign* or give way line at an intersection)
  - rule 70 (Giving way at a *give way sign* at a bridge or length of narrow road)
  - rule 71 (Giving way at a *give way sign* or give way line at other places)
- Part 8 (Traffic signs and road markings), except:
  - rule 102 (Clearance and low clearance signs)
  - rule 103 (Load limit signs)
- rule 111 (3) (which is about entering a roundabout from the right marked lane or line of traffic)
- rule 116 (Obeying traffic lane arrows when driving in or leaving a roundabout)
- Part 11 (Keeping left, overtaking and other driving rules)
- Part 12 (Restrictions on stopping and parking)
- rule 268 (How persons must travel in or on a motor vehicle)
- rule 288 (Driving on a path)
- rule 289 (Driving on a nature strip)
- rule 290 (Driving on a traffic island)
- rule 296 (Driving a vehicle in reverse)
- rule 297 (2) (which requires a driver to have a clear view of the surrounding road and traffic).

**312 Exemption for tow truck drivers**

- (1) It is a defence to the prosecution of the driver of a tow truck for an offence against a provision mentioned in subrule (2) if, at the time of the offence:
- (a) the driver is engaged in loading, or connecting to, a vehicle to which this rule applies; and
  - (b) the driver is unable to comply with the provision; and
  - (c) the tow truck is displaying a flashing light; and
  - (d) the driver is acting safely.
- (2) For subrule (1), the provisions are as follows:
- Part 4 (Making turns)
  - Part 6 (Traffic lights and twin red lights)
  - Part 7 (Giving way), Division 1 (Places with *stop signs*, stop lines, *give way signs* or give way lines)
  - Part 8 (Traffic signs and road markings)
  - Part 9 (Roundabouts)



**Rule 313**

- Part 11 (Keeping left, overtaking and other driving rules)
  - Part 12 (Restrictions on stopping and parking)
  - rule 288 (Driving on a path)
  - rule 289 (Driving on a nature strip)
  - rule 290 (Driving on a traffic island).
- (3) This rule applies to the following vehicles:
- (a) a vehicle at the scene of a crash;
  - (b) a disabled vehicle;
  - (c) a vehicle unsafely or unlawfully parked that the driver is authorised to tow away under another law of this jurisdiction.

*Note* **Crash** is defined in the dictionary, and **vehicle** is defined in rule 15.

**313 Exemption for postal vehicles**

- (1) Another law of this jurisdiction may provide that a provision mentioned in subrule (2) does not apply to the driver of a postal vehicle.

*Note* **Postal vehicle** is defined in the dictionary.

- (2) This rule applies to the following provisions:
- rule 179 (Stopping in a loading zone)
  - rule 180 (Stopping in a truck zone)
  - rule 182 (Stopping in a taxi zone)
  - rule 184 (Stopping in a minibus zone)
  - rule 185 (Stopping in a permit zone)
  - rule 186 (Stopping in a mail zone)
  - rule 189 (Double parking)
  - rule 190 (Stopping in or near a safety zone)
  - rule 191 (Stopping near an obstruction)
  - rule 192 (Stopping on a bridge or in a tunnel etc)
  - rule 193 (Stopping on a crest or curve outside a built-up area)
  - rule 198 (Obstructing access to and from a footpath, driveway etc)
  - rule 288 (Driving on a path).

***THIS PAGE INTENTIONALLY LEFT BLANK***

## Part 20 Traffic control devices and traffic-related items

### Division 1 General

*Note* *Traffic control device* and *traffic-related item* are defined in the dictionary.

#### 314 Diagrams of traffic control devices, traffic-related items and symbols

- (1) A diagram in the *Australian Road Rules* of a traffic control device, traffic-related item, or symbol, represents a likeness of the device, item or symbol.
- (2) If there are 2 or more diagrams of a traffic sign in Schedules 2 and 3, or of a traffic-related item or symbol in Schedule 4, each diagram represents a likeness of a permitted version of the sign, item or symbol.

*Note 1* *Traffic sign* is defined in the dictionary.

*Note 2* A number of traffic signs, traffic-related items or symbols have 2 or more permitted versions.

- (3) If a diagram of a traffic sign in Schedule 2 or 3, or of a traffic-related item or symbol in Schedule 4, is in black and white, the permitted version of the sign, item or symbol is in black and white only.
- (4) If a diagram of a traffic sign, traffic-related item or symbol in a rule of the *Australian Road Rules* is in black and white and the sign, item or symbol is not in black and white only in Schedule 2, 3 or 4, the diagram is a black and white representation of the sign, item or symbol, and is not a permitted version of the sign, item or symbol.

*Note* The permitted version is the version shown in Schedule 2, 3 or 4 (which is in colour) — see rules 316 (1) (a) and 320 (1) (a).

#### 315 Legal effect of traffic control devices mentioned in the Australian Road Rules

- (1) A traffic control device of a kind mentioned in the *Australian Road Rules* has effect for the Rules if:
  - (a) the device is on a road; and
  - (b) the device complies substantially with the Rules.

*Note 1* *Road* includes a road-related area — see rule 11 (2).

*Note 2* Rule 322 (1) and (2) explain the meaning of a traffic control device *on* a road.

- (2) A traffic control device is taken to comply substantially with the *Australian Road Rules* unless the contrary is proved.

#### 316 When do traffic control devices comply substantially with the Australian Road Rules

- (1) A traffic sign complies substantially with the *Australian Road Rules* if:
  - (a) it is a reasonable likeness of a diagram in Schedule 2 or 3 of that kind of traffic sign; or
  - (b) for a traffic sign of a kind for which there is not a diagram in Schedule 2 or 3 — it complies substantially with a description of that kind of traffic sign in the Rules and, if the description includes a symbol for which there is a diagram in Schedule 4, the symbol on the sign is a reasonable likeness of the diagram.

*Note 1* *Traffic sign* is defined in the dictionary.

*Note 2* The diagrams of traffic signs in Schedules 2 and 3 are in alphabetical order.

- (2) A road marking complies substantially with the *Australian Road Rules* if it complies substantially with a description of that kind of road marking in the Rules and, if the description includes a symbol for which there is a diagram in Schedule 4, the symbol in the road marking is a reasonable likeness of the diagram.

*Note Road marking* is defined in the dictionary.

- (3) A traffic control device (except a traffic sign or a road marking) complies substantially with the *Australian Road Rules* if the device complies substantially with a description of that kind of traffic control device in the Rules and, if the description includes a symbol for which there is a diagram in Schedule 4, the symbol on the device is a reasonable likeness of the diagram.
- (4) A traffic sign may be a reasonable likeness of a diagram of a kind of traffic sign mentioned in the *Australian Road Rules* even though:
- (a) the dimensions of the sign, or of anything on the sign, are different; or
  - (b) the sign has additional information on or with it; or
  - (c) the number on the sign is different; or
  - (d) the sign has a different number of panels; or
  - (e) the sign is combined on a single panel with 1 or more other traffic signs; or
  - (f) for a parking control sign — words, figures, symbols, or anything else, on the sign are differently arranged; or
  - (g) for a *bus lane sign*, *emergency stopping lane only sign*, *one-way sign* or parking control sign — the sign has an arrow pointing in a different direction; or
  - (h) for a *separated footpath sign* or an *end separated footpath sign* — the pedestrian and bicycle symbols are reversed; or
  - (i) for a *road access sign* — information on or with the sign indicates (whether by different wording or in another way) that it applies to different or additional vehicles or persons; or
  - (j) there is a variation in shade or brightness between a colour on the sign and the equivalent colour in the diagram.

*Example of subrule (4) (b)*

A *speed-limit sign* near a school may say that the sign has effect at certain times. This additional information does not prevent the sign being a reasonable likeness of the diagram of a *speed-limit sign* in Schedule 2.

*Example of subrule (4) (c)*

The diagram of the *area speed-limit sign* in Schedule 2 has the number '60'. A particular *area speed-limit sign* may have another number eg '50'. The different number on the sign does not prevent the sign being a reasonable likeness of the diagram.

*Examples of subrule (4) (d)*

1 A *school zone sign* may have the indicated speed limit, the words 'school zone', and the times of operation, on a single panel or separate panels.

2 An *end bicycle path sign* may have the word 'end' on a separate panel or on the same panel as the rest of the sign.

*Example of subrule (4) (e)*

A *no parking sign* that operates at certain times may be combined on a single panel with a *permissive parking sign* allowing pay parking at other times.

*Example of subrule (4) (f)*

A *permissive parking sign* limiting parking to 2 hours may have the time limit above, or below, the word 'parking'.

*Example of subrule (4) (i)*

The diagram of the *road access sign* in Schedule 2 says 'no pedestrians bicycles animals beyond this point'. The replacement of the word 'bicycles' by the word 'tractors' on a particular sign does not prevent the sign being a reasonable likeness of the diagram.

*Note* *Bicycle symbol, parking control sign, pedestrian symbol* and *with* are defined in the dictionary.

- (5) A variable illuminated message sign may also be a reasonable likeness of a diagram of a kind of traffic sign in Schedule 2 or 3 even though the colour of the sign, or of anything else on the sign, is different.

*Note* *Variable illuminated message sign* is defined in the dictionary.

*Example of standard sign and variable illuminated message sign*

## Speed-limit signs

Speed-limit sign  
(Standard sign)



Speed-limit sign  
(Variable illuminated message sign)



- (6) A symbol on or in a traffic control device may be a reasonable likeness of a diagram of a kind of symbol mentioned in the *Australian Road Rules* even though the dimensions of the symbol, or of anything on the symbol, are different.

- (7) In this rule:

*panel* includes a board, plate and screen.

**317 Information on or with traffic control devices**

- (1) A traffic control device may, by the use of words, figures, symbols or anything else, indicate any of the following:
- the times, days or circumstances when it applies or does not apply;
  - the lengths of road or areas where it applies or does not apply;
  - the persons to whom it applies or does not apply;
  - the vehicles to which it applies or does not apply;
  - other information.

*Examples of circumstances*

- A *speed-limit sign* may indicate that it applies when the lights at a children's crossing are flashing.
- A *speed-limit sign* may indicate that it applies when children are present.

(2) In this rule:

**traffic control device** includes a board, device, plate, screen, word, figure, symbol, or anything else, with a traffic control device that provides information about the application of the traffic control device.

*Examples of information with a traffic control device*

- 1 A plate erected immediately below a *no U-turn sign* indicating that the sign applies on Monday to Friday between 8 am and 6 pm.
- 2 An illuminated board erected close to, but not next to, a *no entry sign* indicating that commercial trucks are permitted to pass the sign when the words on the board are illuminated.

*Note* **With** includes accompanying or reasonably associated with — see the definition in the dictionary.

### **318 Limited effect of certain traffic control devices**

(1) If information on a traffic control device indicates that the device applies during particular times, on particular days, in particular circumstances, to a particular length of road or area, or to particular persons or vehicles, the device has effect only for the indicated times, days, circumstances, length of road, area, persons or vehicles.

*Example*

A *shared zone sign* on a road into an area indicating that the sign applies on Monday to Friday between 7 am and 6 pm.

(2) If information on a traffic control device indicates that the device does not apply during particular times, on particular days, in particular circumstances, to a particular length of road or area, or to particular persons or vehicles, the device does not have effect for the indicated times, days, circumstances, length of road, area, persons or vehicles.

*Examples*

- 1 A plate erected next to a *pedestrian crossing sign* at a place indicating that the sign does not apply on a particular day.
- 2 A board erected close to a *bus lane sign* above a marked lane indicating that the sign does not apply when the words on the board are illuminated.

(3) If information on a traffic control device that is at a place indicates that it applies on a particular day of the week, the device does not have effect on a day that is a public holiday for the place unless information on the device states otherwise.

*Example*

If a *loading zone sign* indicates that it applies on Monday to Friday between 9 am and 4 pm and information on or with the sign does not indicate that it applies on public holidays, the sign does not have effect on any public holiday falling on a Monday to Friday.

*Note* **Public holiday** is defined in the dictionary.

(4) In this rule:

*traffic control device* includes a board, device, plate, screen, word, figure, symbol, or anything else, with a traffic control device that provides information about the application of the traffic control device.

### **319 Legal effect of traffic-related items mentioned in the Australian Road Rules**

- (1) A traffic-related item of a kind mentioned in the *Australian Road Rules* has effect for the Rules if:
  - (a) the item is on a road, or on a vehicle on a road; and
  - (b) the item complies substantially with the Rules.
- (2) A traffic-related item is taken to comply with the *Australian Road Rules* unless the contrary is proved.

*Note 1* **Road** includes a road-related area — see rule 11 (2).

*Note 2* Rule 322 (1) and (2) explain the meaning of a traffic control device **on** a road.

### **320 When do traffic-related items comply substantially with the Australian Road Rules**

- (1) A traffic-related item complies substantially with the *Australian Road Rules* if:
  - (a) it is a reasonable likeness of a diagram in Schedule 4 of that kind of traffic-related item; or
  - (b) for a traffic-related item of a kind for which there is not a diagram in Schedule 4 — it complies substantially with a description of that kind of traffic-related item in the Rules and, if the description includes a symbol for which there is a diagram in Schedule 4, the symbol on the item is a reasonable likeness of the diagram.
- (2) A traffic-related item may be a reasonable likeness of a diagram of a kind of traffic-related item mentioned in the *Australian Road Rules* even though:
  - (a) the dimensions of the item, or of anything on the item, are different; or
  - (b) the item has additional information.
- (3) A symbol on a traffic-related item may be a reasonable likeness of a diagram of a kind of symbol mentioned in the *Australian Road Rules* even though the dimensions of the symbol, or of anything on the symbol, are different.

### **321 Meaning of information on or with traffic control devices and traffic-related items**

A word, figure, symbol or anything else used on or with a traffic control device or traffic-related item has the same meaning as in the *Australian Road Rules*.

*Note* Rule 347 and Schedule 1 deal with the meaning of certain abbreviations and symbols.

### **322 References to traffic control devices and traffic-related items on a road etc**

- (1) A traffic control device or traffic-related item above or near a road is taken to be on the road.

#### *Examples*

- 1 A *speed-limit sign* erected on a post at the side of a road is taken to be a *speed-limit sign* on the road.
- 2 A traffic lane arrow on a structure immediately above the road is taken to be a traffic lane arrow on the road.

- (2) However, the device or item is taken to be on the road only if it is clearly visible to road users to whom it is designed to apply.

*Example*

A *shared zone sign* erected on a post near the side of a road is a traffic sign on the road only if it is clearly visible to drivers driving on the road during the day and in normal weather conditions.

*Note* **Clearly visible** is defined in subrule (8).

- (3) A traffic control device or traffic-related item above or near an area or place is taken to be in or at the area or place.

*Examples*

1 Traffic lights erected outside the area of an intersection, but near that area, are taken to be traffic lights at the intersection.

2 A *hook turn only sign* fixed to a structure above a road that is close to, but before, an intersection is taken to be a *hook turn only sign* at the intersection.

3 A parking control sign near the side of a road is taken to be at the side of the road.

4 A parking control sign near the centre of a road is taken to be at the centre of the road.

- (4) However, the device or item is taken to be in or at the area or place only if it is clearly visible to road users to whom it is designed to apply.

*Example*

A *no right turn sign* suspended from wires above a road close to, but before, an intersection is a traffic sign at the intersection only if it is clearly visible to drivers approaching the intersection during the day and in normal weather conditions.

- (5) Without limiting subrule (3), a traffic control device or traffic-related item above or near a break in a dividing strip is taken to be at the break.

*Example*

A *no U-turn sign* erected in a dividing strip close to, but before, a break in the dividing strip is taken to be at the break.

*Note* **Dividing strip** is defined in the dictionary.

- (6) However, the device or item is taken to be at the break only if it is clearly visible to road users to whom it is designed to apply.

- (7) A traffic control device or traffic-related item is taken to comply with subrule (2), (4) or (6) unless the contrary is proved.

- (8) In this rule:

**clearly visible** means:

(a) for a traffic signal — clearly visible during the day and night in normal weather conditions;  
or

(b) for another traffic control device or a traffic-related item — clearly visible during the day in normal weather conditions.

*Note* **Night** is defined in the dictionary.

**day** means the period between sunrise on a day and sunset on the same day.

**normal weather conditions** means weather conditions that are not hazardous weather conditions causing reduced visibility.



---

**323 References to lights that are traffic signals**

A reference in the *Australian Road Rules* to a light that is, or is part of, traffic signals is a reference to a steady light, unless otherwise expressly stated.

*Note* **Traffic signals** is defined in the dictionary.

## **Division 2 Application of traffic control devices to lengths of roads and areas**

*Note* *Area*, *length* of road and *traffic control device* are defined in the dictionary.

### **324 Purpose of Division**

- (1) This Division contains rules explaining when traffic control devices apply to lengths of road and areas.
- (2) Other relevant rules are found elsewhere in the *Australian Road Rules*.

*Note* These rules include:

- rule 21 (3) — length of road to which a *speed-limit sign* applies
- rule 22 (2) — speed-limited area
- rule 23 (2) — school zone
- rule 24 (2) — shared zone
- rule 39 (3) — length of road to which a *no U-turn sign* applies
- rule 93 (2) — length of road to which a *no overtaking or passing sign* applies
- rule 97 (2) — length of road to which a *road access sign* applies
- rule 98 (2) — length of road to which a *one-way sign* applies
- rule 108 (3) — length of road to which a *trucks and buses low gear sign* applies
- rule 130 (3) — length of road to which a *keep left unless overtaking sign* applies
- rule 159 (2) — length of road to which a traffic sign indicating a marked lane for a particular kind of vehicle applies
- rule 176 (2) and (3) — length of road to which a *clearway sign* applies
- rule 177 (3) — length of road to which a *freeway sign* applies
- rule 252 (2) — length of road or footpath to which a *no bicycles sign*, or no bicycles road marking, applies.

### **325 References to traffic control devices — application to lengths of road and areas**

In applying the *Australian Road Rules* to a length of road or an area, unless the contrary intention appears, a reference to a traffic control device is a reference to a traffic control device applying to the length of road or area.

### **326 When do traffic control devices apply to a length of road or area — the basic rules**

- (1) A traffic control device applies to a length of road or an area if:
  - (a) the device applies to the length of road or area under 1 or more provisions of the *Australian Road Rules*; or
  - (b) the device, the position of the device, or information on or with the device, indicates that the device applies to the length of road or area.

*Note* *With* is defined in the dictionary.

- (2) A traffic control device does not apply to a length of road or an area if information on or with the device expressly indicates that it does not apply to the length of road or area.

- (3) Subrule (2) applies despite any other provision of this Division.
- (4) In subrule (1) (b):  
*the device* includes another traffic control device.

### **327 Length of road to which a traffic sign (except a parking control sign) applies**

The length of road to which a traffic sign on a road (except a parking control sign) applies is worked out in the direction driven by a driver, or travelled by a pedestrian, on the road who faces the sign before passing it.

#### *Example*

Rule 21 (3) provides that a *speed-limit sign* applies to the length of road beginning at the sign and ending at the nearest of a different *speed-limit sign*, an *end speed-limit sign*, or *speed derestriction sign*, and the end of the road. Only the nearest of those things, in the direction driven by a driver, or travelled by a pedestrian, who faces the sign before passing it, is relevant.

*Note 1* **Parking control sign** and **traffic sign** are defined in the dictionary.

*Note 2* Rule 332 deals with parking control signs that display an arrow. These signs apply to lengths of road.

### **328 References to a traffic control device applying to a length of road**

If, under the *Australian Road Rules*, a traffic control device on a road applies to a length of road, the device applies only to a length of road on that road, unless otherwise expressly stated.

#### *Example*

A *speed-limit sign* on a road does not apply to roads leading off from the road.

*Note* **Length** of road is defined in the dictionary.

### **329 Traffic control devices applying to a marked lane**

- (1) A traffic control device (except a road marking) applies to a marked lane if:
  - (a) it is above the marked lane; or
  - (b) it is near the marked lane, and the device, the position of the device, or information on or with the device, indicates that it applies to the marked lane.

#### *Example*

An *emergency stopping lane only sign* applies to the marked lane indicated by the arrow on the sign.

*Note* **Marked lane**, **road marking** and **with** are defined in the dictionary.

- (2) A road marking applies to a marked lane if it is on the surface of the lane.
- (3) However, a traffic control device does not apply to a marked lane if information on or with the device expressly indicates that the device does not apply to the marked lane.
- (4) In subrule (1) (b):  
*the device* includes another traffic control device.

### **330 Traffic control devices applying to a slip lane**

- (1) A traffic control device (except a road marking) applies to a slip lane if:
  - (a) it is above the slip lane; or
  - (b) it is near the slip lane and on the left side of the slip lane; or

**Rule 331**

---

- (c) it is near the slip lane, and the device, the position of the device, or information on or with the device, indicates that it applies to the slip lane.

*Note* **Road marking, slip lane** and **with** are defined in the dictionary.

- (2) A road marking applies to a slip lane if it is on the surface of the slip lane.
- (3) However, a traffic control device does not apply to a slip lane if information on or with the device expressly indicates that the device does not apply to the slip lane.
- (4) In subrule (1) (c):  
*the device* includes another traffic control device.

**331 Traffic control devices applying to an intersection**

A traffic control device applies to an intersection if it is at the intersection and does not apply to a slip lane at the intersection, unless information on or with the device expressly indicates that the device does not apply to the intersection.

*Note 1* **Intersection, slip lane** and **with** are defined in the dictionary.

*Note 2* Rule 322 (3) and (4) deal with the meaning of a traffic control device **at** an area, including an intersection.

*Note 3* Rule 330 explains when a traffic control device applies to a slip lane.

**332 Parking control signs applying to a length of road**

- (1) If a parking control sign displays an arrow and is at the side of a road, then, unless information on or with the sign indicates otherwise, the sign applies to the length of road between the sign and the nearest (in the direction indicated by the arrow) of the following:
- (a) a parking control sign at that side of the road that displays an arrow indicating the opposite direction;
- (b) a yellow edge line on the road;
- (c) if the road ends at a T-intersection or dead end — the end of the road.

*Note 1* **Edge line, parking control sign, T-intersection** and **with** are defined in the dictionary.

*Note 2* Rule 322 (3) and (4) deal with the meaning of a traffic control device **in** or **at** an area or place.

- (2) If a parking control sign displays an arrow and is at the centre of a road or on a dividing strip, then, unless information on or with the sign indicates otherwise, the sign applies to the length of road between the sign and the nearest (in the direction indicated by the arrow) of the following:
- (a) a parking control sign at the centre of the road or on the dividing strip that displays an arrow indicating the opposite direction;
- (b) a yellow edge line on the road;
- (c) if the road ends at a T-intersection or dead end — the end of the road.

*Note* **Centre of the road** and **dividing strip** are defined in the dictionary.

**333 Parking control signs applying to a length of road in an area to which another parking control sign applies etc**

- (1) If a parking control sign that applies to a length of road is in an area to which another parking control sign applies in accordance with rule 335, the first parking control sign applies in the same

way as it would apply if it were not in that area, and the second parking control sign does not apply to the length of road.

*Example*

Parking control signs that establish a loading zone or taxi zone may operate on a length of road in an area where parking is otherwise restricted to residents only by other parking control signs on each road into the area.

*Note* **Parking control sign** is defined in the dictionary.

- (2) If the area indicated by a people with disabilities road marking is in an area to which a parking control sign applies in accordance with rule 335, the road marking applies in the same way as it would apply if it were not in that area, and the parking control sign does not apply to the area indicated by the road marking.

*Note* **People with disabilities road marking** is defined in rule 203.

### 334 How parking control signs apply to a length of road

- (1) If a parking control sign applies to a length of road and there are parking bays on the length of road, the sign applies only to the parking bays, unless information on or with the sign indicates otherwise.

*Note* **Parking bay**, **parking control sign** and **with** are defined in the dictionary.

- (2) If a parking control sign applies to a length of road, the sign is at the side of the road, and there are no parking bays to which the sign applies, then, unless information on or with the sign indicates otherwise, the sign applies to the part of the road on the length of road that extends from the far side of the road (excluding any road-related area) on that side of the road for:
  - (a) if the sign, or information on or with the sign, includes the words ‘angle parking’ or ‘angle’ — 6 metres; or
  - (b) in any other case — 3 metres.

*Note* **Road-related area** is defined in rule 13.

*Examples*

Example 1  
Part of a road to which a parking control sign indicating angle parking applies

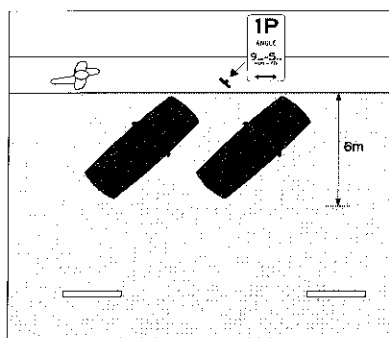

Example 2  
Part of a road to which a parking control sign (except a sign indicating angle parking) applies

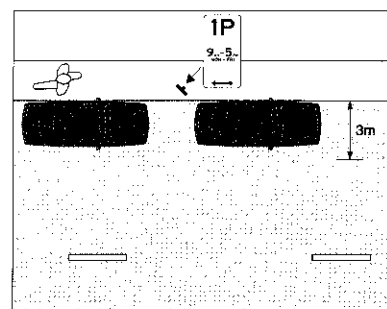

**Rule 335**

---

- (3) If a parking control sign applies to a length of road, the sign is at the centre of the road or on a dividing strip, and there are no parking bays to which the sign applies, then, unless information on or with the sign indicates otherwise, the sign applies to:
- (a) if the sign is at the centre of the road, but not on a dividing strip — the part of the road on that length of road that extends 3 metres from the centre of the road on each side of the road; or
  - (b) if the sign is on a dividing strip — the dividing strip on that length of road and the part of the road on that length of road that extends 3 metres from each edge of the dividing strip.

*Note 1* **Centre of the road** and **dividing strip** are defined in the dictionary.

*Note 2* Rule 322 (3) and (4) deal with the meaning of a traffic control device *in* or *at* an area or place.

### 335 Traffic control devices applying to an area

- (1) A traffic control device (except a road marking) applies to an area if:
- (a) it is *in* the area; and
  - (b) the device, the position of the device, or information on or with the device, indicates that the device applies to the area.

*Note 1* **Road marking** and *with* are defined in the dictionary.

*Note 2* Rule 332 deals with parking control signs that display arrows. These signs apply to lengths of road.

- (2) A traffic control device (except a road marking) also applies to an area if:
- (a) there is an identical kind of traffic control device (the **first traffic control device**) on each road into the area; and
  - (b) the traffic control device is a traffic control device applying to an area, or information on or with the device indicates that it applies to an area; and
  - (c) information on or with a traffic control device on each road out of the area indicates that the first traffic control device no longer applies or that the area has ended.

*Examples of traffic control devices applying to an area*

- 1 A *school zone sign* (in some circumstances — see rule 23).
- 2 A *shared zone sign*.
- 3 A *no stopping sign* or *no parking sign* with the word 'area'.
- 4 A *permissive parking sign* with the words 'parking area'.

- (3) A road marking applies to an area if:
- (a) it is on the surface of the area; and
  - (b) the road marking, the position of the road marking, or information in or with the road marking, indicates that the road marking applies to the area.
- (4) However, a traffic control device does not apply to an area if information on or with the device expressly indicates that the device does not apply to the area.
- (5) A parking control sign that applies to an area applies to parking bays on each length of road in the area, and to other parts of each length of road, as if it were a parking control sign that applied only to that length of road.

*Note 1* **Parking bay** and **parking control sign** are defined in the dictionary.

*Note 2* Rule 334 sets out how a parking control sign that applies to a length of road also applies to parking bays and other parts of the road.

(6) In this rule:

*road*, in subrule (2) (a) and (c) and for an area of road, does not include a road-related area.

*the device*, in subrule (1) (b), includes another traffic control device.

*the road marking*, in subrule (3) (b), includes another traffic control device.

*Note Road-related area* is defined in rule 13.

### **336 How separated footpath signs and separated footpath road markings apply**

(1) A *separated footpath sign*, or separated footpath road marking, on a footpath applies in the way set out in this rule.

*Note Footpath* is defined in the dictionary, and *separated footpath* and *separated footpath road marking* are defined in rule 239.

(2) The part of the footpath to the left of the centre of the footpath is designated:

(a) if a pedestrian symbol is on the left side of the sign or the path — for the use of pedestrians;  
or

(b) if a bicycle symbol is on the left side of the sign or the path — for the use of bicycles.

*Note Bicycle, bicycle symbol* and *pedestrian symbol* are defined in the dictionary, and *pedestrian* is defined in rule 18.

(3) The part of the footpath to the right of the centre of the footpath is designated:

(a) if a pedestrian symbol is on the right side of the sign or the path — for the use of pedestrians; or

(b) if a bicycle symbol is on the right side of the sign or the path — for the use of bicycles.

## **Division 3 Application of traffic control devices to persons**

*Note* **Traffic control device** is defined in the dictionary.

### **337 Purpose of Division**

This Division explains when a traffic control device applies to a person.

### **338 References to traffic control devices — application to persons**

In applying the *Australian Road Rules* to a person, unless the contrary intention appears, a reference to a traffic control device is a reference to a traffic control device applying to the person.

### **339 When do traffic control devices apply to a person — the basic rules**

- (1) A traffic control device applies to a person if:
  - (a) the device applies to the person under a provision of this Division; or
  - (b) the device, the position of the device, or information on or with the device, indicates that the device applies to the person.

*Note* **With** is defined in the dictionary.

- (2) A traffic control device does not apply to a person if information on or with the device expressly indicates that it does not apply to the person.
- (3) Subrule (2) applies despite any other provision of this Division.
- (4) In subrule (1) (b):

*the device* includes another traffic control device.

### **340 Traffic control devices (except road markings and parking control signs)**

- (1) A traffic control device (except a road marking or parking control sign) applies to a person if:
  - (a) the device faces the person; or
  - (b) the person has passed the device and the device faced the person as the person approached it.

*Note 1* **Parking control sign** and **road marking** are defined in the dictionary.

*Note 2* Rule 341 deals with road markings, and rule 346 with parking control signs.

- (2) However, the device does not apply to the person if the position of the device indicates that it does not apply to the person.

#### *Examples*

- 1 If a driver is driving in a marked lane of a multi-lane road, a traffic lane arrow above another marked lane does not apply to the driver.
- 2 If a driver is turning left using a slip lane at an intersection, a traffic light on the right side of the slip lane does not apply to the driver.
- 3 If a driver is driving on a two-way road, a *speed-limit sign* facing only traffic travelling in the opposite direction does not apply to the driver.



### 341 Road markings

A road marking on the surface of a road applies to a person on the road unless the position of the road marking indicates that it does not apply to the person.

#### *Examples*

- 1 If a driver is driving on a road that is not a multi-lane road or one-way road, a road marking to the right of the centre of the road does not apply to the driver.
- 2 If a driver is driving in a marked lane of a multi-lane road, a road marking in another marked lane does not apply to the driver.

*Note* **Road marking** is defined in the dictionary.

### 342 Traffic signs (except parking control signs) applying to a length of road

- (1) A traffic sign (except a parking control sign) that applies to a length of road and to drivers applies to a driver driving on the length of road if the driver is driving in the same direction as a driver on the road who faces the sign before passing it.

*Note* **Length** of road, **parking control sign** and **traffic sign** are defined in the dictionary.

- (2) A traffic sign that applies to a length of road and to pedestrians applies to a pedestrian travelling on the length of road if the pedestrian is travelling in the same direction as a pedestrian on the road who faces the sign before passing it.
- (3) The traffic sign applies to the driver or pedestrian even though the driver or pedestrian does not pass the sign.

#### *Example*

If a driver turns from a side road or private land onto a length of road to which a traffic sign applies, the traffic sign applies to the driver even though the driver does not pass the sign.

### 343 Traffic signs (except parking control signs) applying to an area

- (1) A traffic sign (except a parking control sign) that applies to an area and to drivers applies to a driver driving on any road in the area.

*Note 1* **Area**, **parking control sign** and **traffic sign** are defined in the dictionary.

*Note 2* Rule 342 deals with traffic signs (except parking control signs) applying to a length of road, and rule 346 deals with the application of parking control signs to lengths of road and areas.

*Note 3* **Road** includes a road-related area — see rule 11 (2).

- (2) A traffic sign that applies to an area and to pedestrians applies to a pedestrian on any road in the area.
- (3) The traffic sign applies to the driver or pedestrian even though the driver or pedestrian does not pass the sign.

#### *Example*

The *shared zone signs* on the roads into a shared zone apply to a driver who starts a journey inside the shared zone.

### **344 Traffic control devices applying to a driver in a marked lane**

A traffic control device applying to a marked lane applies to a driver approaching, in or leaving the marked lane unless the position of the device indicates that it does not apply to the driver.

*Example*

An overhead lane control device above a marked lane that the driver does not face as the driver approaches it does not apply to the driver.

*Note 1* **Marked lane** is defined in the dictionary.

*Note 2* Rule 329 deals with when a traffic control device applies to a marked lane.

### **345 Traffic control devices applying to a driver in a slip lane**

A traffic control device applying to a slip lane applies to a driver approaching, in or leaving the slip lane.

*Note 1* **Slip lane** is defined in the dictionary.

*Note 2* Rule 330 deals with when a traffic control device applies to a slip lane.

### **346 Parking control signs**

- (1) A parking control sign that applies to a length of road applies to a driver on the length of road.

*Note 1* **Length** of road and **parking control sign** are defined in the dictionary.

*Note 2* Rule 332 deals with parking control signs with arrows. These signs apply to lengths of road.

- (2) A parking control sign that applies to an area applies to a driver in the area.

*Note* **Area** is defined in the dictionary.

- (3) A parking control sign applies to a driver mentioned in subrule (1) or (2) even though the driver does not pass the sign.

## Part 21 General

### 347 Meaning of abbreviations and symbols

- (1) Schedule 1 provides the meaning of certain abbreviations and symbols used in the *Australian Road Rules* and on traffic control devices and traffic-related items.

*Note* *Traffic control device* and *traffic related item* are defined in the dictionary.

- (2) Another law of this jurisdiction may provide the meaning of other abbreviations or symbols on traffic control devices and traffic-related items.

### 348 References to a driver doing something etc

If the context permits, a reference in the *Australian Road Rules* to a driver doing or not doing something is a reference to the driver causing the driver's vehicle to do or not to do the thing.

*Example*

The reference in rule 27 to a driver turning left at an intersection is a reference to the driver causing the driver's vehicle to turn left at the intersection.

*Note* *Driver's vehicle* is defined in the dictionary.

### 349 References to certain kinds of roads

A reference in the *Australian Road Rules* to a road of a particular kind is a reference to a road of that kind at any relevant place.

*Example*

Rule 31 deals with a driver starting a right turn at an intersection from a road (except a multi-lane road). The rule applies to a particular driver only if the road from which the driver is turning is not a multi-lane road at the intersection. In applying the rule to the driver, it is irrelevant that the road is, or is not, a multi-lane road at another place away from the intersection.

### 350 References to stopping or parking on a length of road etc

- (1) A driver stops or parks on a length of road, or in an area, if the driver stops or parks the driver's vehicle so any part of the vehicle is on the length of road or in the area.

*Note* *Area*, *driver's vehicle* and *length* of road are defined in the dictionary.

- (2) A driver stops or parks within a particular distance from, before, or after, something if the driver stops or parks the driver's vehicle so any part of the vehicle is within that distance.

*Example for subrule (2)*

Rule 190 provides that a driver must not stop on a road within 10 metres before or after a safety zone. The example diagram in rule 190 shows a vehicle stopped so part of the vehicle is within 10 metres of the zone. For rule 190, the vehicle is taken to be stopped within 10 metres of the zone.

- (3) A driver stops or parks on or across a driveway or other way of access for vehicles if the driver stops or parks the driver's vehicle so that any part of the vehicle is on or across the driveway or way of access.

- (4) In this rule:

*park* has the same meaning as in Part 12.

**Rule 351**

---

*stop* has the same meaning as in Part 12.

*Note 1* Part 12 deals with restrictions on stopping and parking.

*Note 2* **Park** and **stop** are defined in the dictionary. The definitions apply for Part 12.

**351 References to left and right**

- (1) In applying the *Australian Road Rules* to a person, a reference to **left** is a reference to:
  - (a) in relation to the person — the left-hand side of the person; or
  - (b) in relation to a line, sign or anything else — the left-hand side of the line, sign or other thing when viewed from the person's perspective.
- (2) In applying the *Australian Road Rules* to a person, a reference to **right** is a reference to:
  - (a) in relation to the person — the right-hand side of the person; or
  - (b) in relation to a line, sign or anything else — the right-hand side of the line, sign or other thing when viewed from the person's perspective.
- (3) A driver drives to the left, or right, of a line, sign or anything else only if the driver's vehicle is completely to the left, or right, of the line, sign or other thing.

*Note* **Driver's vehicle** is defined in the dictionary.

## Schedule 1      Abbreviations and symbols







(rule 347)



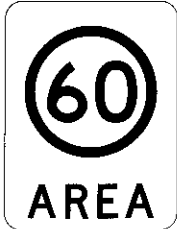

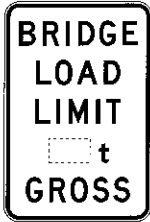
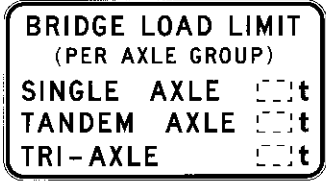

Abbreviation/Symbol	Meaning
MON	Monday
TUE	Tuesday
WED	Wednesday
THU	Thursday
FRI	Friday
SAT	Saturday
SUN	Sunday
JAN	January
FEB	February
MAR	March
APR	April
JUN	June
JUL	July
AUG	August
SEP	September
OCT	October
NOV	November
DEC	December
AM	the time after midnight and ending at noon
PM	the time after noon and ending at midnight
HOLS	holidays
MAX	maximum
MINS	minutes
PUB	public
VEH	vehicle
t	tonnes

Abbreviation/Symbol	Meaning
m	metres
km	kilometres
km/h	kilometres per hour
°	degree

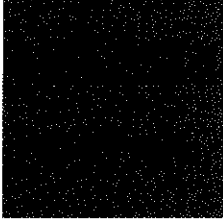

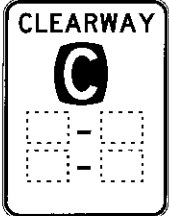

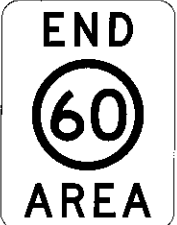



## Schedule 2 Standard or commonly used traffic signs









(rule 316)

<p>Area speed-limit sign (rule 22)</p> 	<p>Bicycle lane sign (rules 153, 252)</p> 
<p>Bicycle parking sign (rule 201)</p> 	<p>Bicycle path sign (rules 239, 242, 252)</p> 
<p>Bridge load limit (gross mass) sign (rule 103)</p> 	<p>Bridge load limit (mass per axle group) sign (rule 103)</p> 
<p>Bus lane sign (rule 154)</p> 	<p>Buses must enter sign (rule 107)</p> 

<p>Bus zone sign (rule 183)</p> 	<p>Children crossing flag (rule 80)</p> 
<p>Children's crossing sign (rule 80)</p> 	<p>Clearance sign (rule 102)</p> 
<p>Clearway sign (rule 176)</p> 	<p>Emergency stopping lane only sign (rule 95)</p> 
<p>End area speed-limit sign (rule 22)</p> 	<p>End bicycle lane sign (rule 153)</p> 

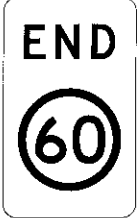

<p>End bicycle path sign (rule 239)</p> 	<p>End bus lane sign (rule 154)</p> 
<p>End clearway sign (rule 176)</p> 	<p>End freeway sign (rules 97, 177)</p> 
<p>End keep left unless overtaking sign (rule 130)</p> 	<p>End no bicycles sign (rule 252)</p> 
<p>End no overtaking or passing sign (rule 93)</p> 	<p>End road access sign (rules 97, 229)</p> 

<p>End school zone sign (rule 23)</p> 	<p>End separated footpath sign (rule 239)</p> 
<p>End shared path sign (rule 242)</p> 	<p>End shared zone sign (rule 24)</p> 
<p>End speed-limit sign (rule 21)</p> 	<p>End tram lane sign (rule 155)</p> 
<p>End transit lane sign (End transit lane (T2) sign) (rule 156)</p> 	<p>End transit lane sign (End transit lane (T3) sign) (rule 156)</p> 

End trucks and buses low gear sign  
(rule 108)



End truck lane sign  
(rule 157)



End trucks use left lane sign  
(rule 159)



Freeway sign  
(rule 177)



Freeway sign  
(rule 177)



Give way sign  
(rules 69, 70, 71, 122)





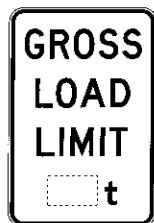



Gross load limit sign  
(rule 103)



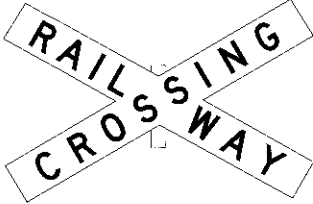
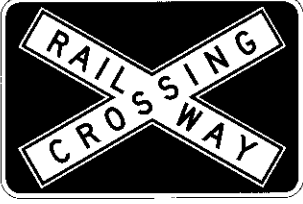
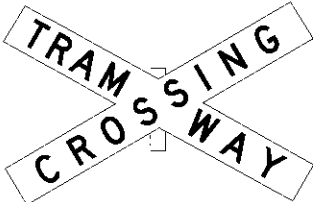







Hand-held stop sign  
(rules 80, 101)



<p>Hand-held stop sign (rules 80, 101)</p> 	<p>Hook turn only sign (rule 34)</p> 
<p>Keep left sign (rule 99)</p> 	<p>Keep left unless overtaking sign (rule 130)</p> 
<p>Keep right sign (rules 99, 135)</p> 	<p>Left lane must turn left sign (rule 88)</p> 
<p>Left turn on red after stopping sign (rule 59)</p> 	<p>Left turn only sign (rule 88)</p> 





<p>Level crossing sign (rule 120)</p> 	<p>Level crossing sign (rule 120)</p> 
<p>Level crossing sign (rule 120)</p> 	<p>Loading zone sign (rule 179)</p> 
<p>Low clearance sign (rule 102)</p> 	<p>Mail zone sign (rule 186)</p> 
<p>Median turning lane sign (rule 86)</p> 	<p>Minibus zone sign (rule 184)</p> 





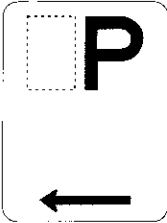
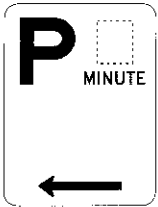
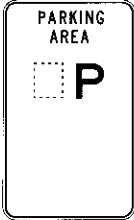

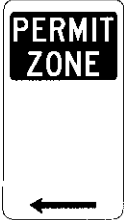

<p>Motor bike parking sign (rule 202)</p> 	<p>No bicycles sign (rules 239, 242, 252)</p> 
<p>No buses sign (rule 106)</p> 	<p>No entry sign (rule 100)</p> 
<p>No hook turn by bicycles sign (rule 36)</p> 	<p>No left turn sign (Standard sign) (rule 91)</p> 
<p>No left turn sign (Variable illuminated message sign) (rule 91)</p> 	<p>No overtaking on bridge sign (rule 94)</p> 









<p>No overtaking or passing sign (rule 93)</p> 	<p>No parking sign (for a length of road) (rule 168)</p> 
<p>No parking sign (for an area) (rule 168)</p> 	<p>No pedestrians sign (rule 228)</p> 
<p>No right turn sign (Standard sign) (rule 91)</p> 	<p>No right turn sign (Variable illuminated message sign) (rule 91)</p> 
<p>No stopping sign (for a length of road) (rule 167)</p> 	<p>No stopping sign (for an area) (rule 167)</p> 







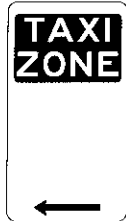

<p>No trucks sign (rule 104)</p> 	<p>No turns sign (rule 90)</p> 
<p>No U-turn sign (Standard sign) (rule 39)</p> 	<p>No U-turn sign (Variable illuminated message sign) (rule 39)</p> 
<p>One-way sign (rule 98)</p> 	<p>Park in bays only sign (rule 211)</p> 
<p>Pedestrian crossing sign (rule 81)</p> 	<p>Pedestrians may cross diagonally sign (rules 230, 234)</p> 



<p>People with disabilities parking sign (rule 203)</p> 	<p>Permissive parking sign (for a length of road) (rule 204)</p> 
<p>Permissive parking sign (for a length of road) (rule 204)</p> 	<p>Permissive parking sign (for an area) (rule 204)</p> 
<p>Permissive parking sign displaying a people with disabilities symbol (for a length of road) (rule 203)</p> 	<p>Permissive parking sign displaying a people with disabilities symbol (for an area) (rule 203)</p> 
<p>Permit zone sign (rule 185)</p> 	<p>Right lane must turn right sign (rule 89)</p> 

<p>Right turn only sign (rule 89)</p> 	<p>Road access sign (rules 97, 229)</p> 
<p>Roundabout sign (rule 109)</p> 	<p>Safety zone sign (rules 162, 190)</p> 
<p>Separated footpath sign (rules 239, 252)</p> 	<p>School zone sign (rule 23)</p> 
<p>Shared path sign (rules 242, 252)</p> 	<p>Shared zone sign (rule 24)</p> 

<p>Speed derestriction sign (rule 21)</p> 	<p>Speed-limit sign (Standard sign) (rules 21, 316)</p> 
<p>Speed-limit sign (Variable illuminated message sign) (rules 21, 316)</p> 	<p>Stop here on red arrow sign (rule 56)</p> 
<p>Stop here on red signal sign (rule 56)</p> 	<p>Stop sign (rules 67, 68, 121)</p> 
<p>Taxi zone sign (rule 182)</p> 	<p>Traffic light-stop sign (rule 63)</p> 

<p>Tram lane sign (rule 155)</p> 	<p>Transit lane sign (Transit lane (T2) sign) (rule 156)</p> 
<p>Transit lane sign (Transit lane (T3) sign) (rule 156)</p> 	<p>Truck lane sign (rule 157)</p> 
<p>Trucks and buses low gear sign (rule 108)</p> 	<p>Trucks must enter sign (rule 105)</p> 
<p>Trucks use left lane sign (rule 159)</p> 	<p>Truck zone sign (rule 180)</p> 

Two-way sign  
(rules 98, 132, 136)

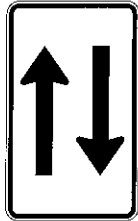

U-turn permitted sign  
(rule 40)

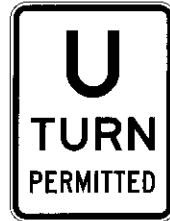

Works zone sign  
(rule 181)

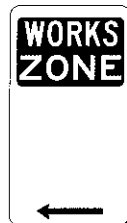









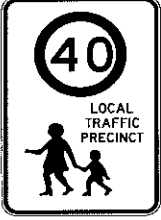



***THIS PAGE INTENTIONALLY LEFT BLANK***

## Schedule 3 Other permitted traffic signs

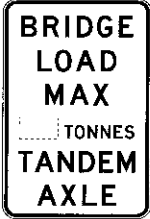
(rule 316)

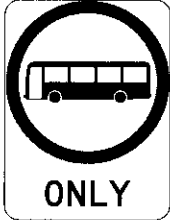

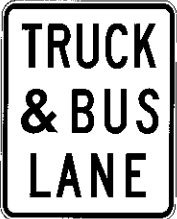

*Note* The traffic signs in this Schedule are alternative versions of the signs in Schedule 2. These signs are not included in the Australian Standard AS1742 (Manual of Uniform Traffic Control Devices), but are still in use in some jurisdictions.







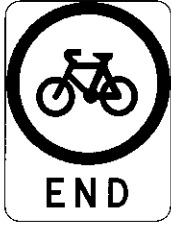

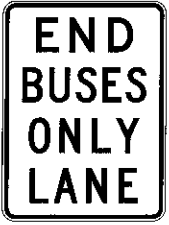
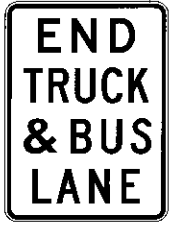
<p>Area speed-limit sign (rule 22)</p> 	<p>Area speed-limit sign (rule 22)</p> 
<p>Area speed-limit sign (rule 22)</p> 	<p>Bicycle lane sign (rules 153, 252)</p> 
<p>Bicycle lane sign (rules 153, 252)</p> 	<p>Bicycle path sign (rules 239, 242, 252)</p> 

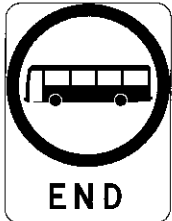



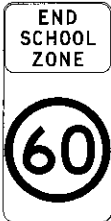
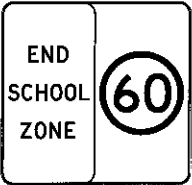

<p>Bicycle path sign (rules 239, 242, 252)</p> 	<p>Bridge load limit (mass per axle group) sign (rule 103)</p> 
<p>Bridge load limit (mass per axle group) sign (rule 103)</p> 	<p>Bus lane sign (rule 154)</p> 
<p>Bus lane sign (rule 154)</p> 	<p>Bus lane sign (rule 154)</p> 
<p>Bus lane sign (rule 154)</p> 	<p>Bus lane sign (rule 154)</p> 



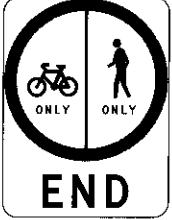

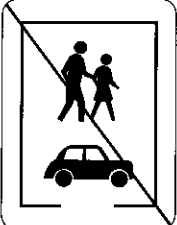

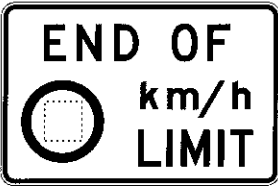
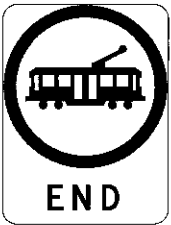
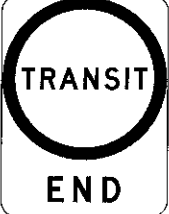













<p>Bus lane sign (rule 154)</p> 	<p>Bus lane sign (rule 154)</p> 
<p>Bus lane sign (rule 154)</p> 	<p>Bus lane sign (rule 154)</p> 
<p>Buses must enter sign (rule 107)</p> 	<p>Bus zone sign (rule 183)</p> 
<p>Bus zone sign (rule 183)</p> 	<p>Children's crossing sign (rule 80)</p> 

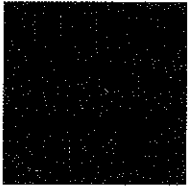





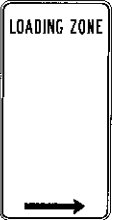

<p>End area speed-limit sign (rule 22)</p> 	<p>End area speed-limit sign (rule 22)</p> 
<p>End area speed-limit sign (rule 22)</p> 	<p>End bicycle lane sign (rule 153)</p> 
<p>End bicycle path sign (rule 239)</p> 	<p>End bicycle path sign (rule 239)</p> 
<p>End bus lane sign (rule 154)</p> 	<p>End bus lane sign (rule 154)</p> 







<p>End bus lane sign (rule 154)</p> 	<p>End bus lane sign (rule 154)</p> 
<p>End freeway sign (rules 97, 177)</p> 	<p>End freeway sign (rules 97, 177)</p> 
<p>End freeway sign (rules 97, 177)</p> 	<p>End freeway sign (rules 97, 177)</p> 
<p>End freeway sign (rules 97, 177)</p> 	<p>End school zone sign (rule 23)</p> 
<p>End school zone sign (rule 23)</p> 	<p>End school zone sign (rule 23)</p> 

<p>End separated footpath sign (rule 239)</p> 	<p>End shared path sign (rule 242)</p> 
<p>End shared zone sign (rule 24)</p> 	<p>End shared zone sign (rule 24)</p> 
<p>End speed-limit sign (rule 21)</p> 	<p>End tram lane sign (rule 155)</p> 
<p>End transit lane sign (rule 156)</p> 	<p>End trucks and buses low gear sign (rule 108)</p> 



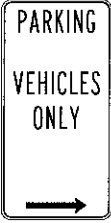





<p>End truck lane sign (rule 157)</p> 	<p>Freeway sign (rule 177)</p> 
<p>Freeway sign (rule 177)</p> 	<p>Freeway sign (rule 177)</p> 
<p>Freeway sign (rule 177)</p> 	<p>Freeway sign (rule 177)</p> 
<p>Freeway sign (rule 177)</p> 	<p>Freeway sign (rule 177)</p> 
<p>Hand-held stop sign (rules 80, 101)</p> 	<p>Hand-held stop sign (rules 80, 101)</p> 

<p>Hand-held stop sign (rules 80, 101)</p> 	<p>Keep right sign (rules 99, 135)</p> 
<p>Left lane must turn left sign (rule 88)</p> 	<p>Left turn only sign (rule 88)</p> 
<p>Left turn only sign (rules 99, 135)</p> 	<p>Loading zone sign (rule 179)</p> 
<p>Loading zone sign (rule 179)</p> 	<p>Median turning lane sign (rule 86)</p> 





<p>No bicycles sign (rules 239, 242, 252)</p> 	<p>No entry sign (rule 100)</p> 
<p>No entry sign (rule 100)</p> 	<p>No entry sign (rule 100)</p> 
<p>No entry sign (rule 100)</p> 	<p>No left turn sign (Standard sign) (rule 91)</p> 
<p>No left turn sign (Variable illuminated message sign) (rule 91)</p> 	<p>No overtaking on bridge sign (rule 94)</p> 





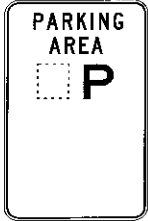
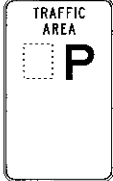

<p>No parking sign (for a length of road) (rule 168)</p> 	<p>No parking sign (for a length of road) (rule 168)</p> 
<p>No parking sign (for a length of road) (rule 168)</p> 	<p>No parking sign (for a length of road) (rule 168)</p> 
<p>No parking sign (for an area) (rule 168)</p> 	<p>No parking sign (for an area) (rule 168)</p> 
<p>No parking sign (for an area) (rule 168)</p> 	<p>No right turn sign (Standard sign) (rule 91)</p> 

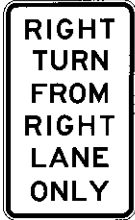
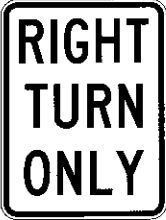

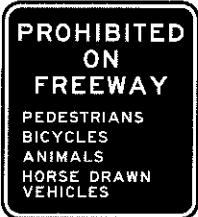



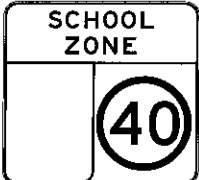



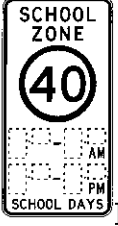
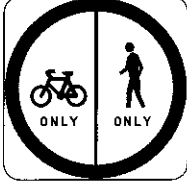



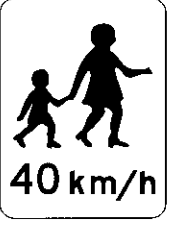



<p>No right turn sign (Variable illuminated message sign) (rule 91)</p> 	<p>No right turn sign (rule 91)</p> 
<p>No stopping sign (for a length of road) (rule 167)</p> 	<p>No stopping sign (for a length of road) (rule 167)</p> 
<p>No stopping sign (for a length of road) (rule 167)</p> 	<p>No stopping sign (for an area) (rule 167)</p> 
<p>No stopping sign (rule 167)</p> 	<p>No U-turn sign (Standard sign) (rule 39)</p> 

<p>No U-turn sign (Variable illuminated message sign) (rule 39)</p> 	<p>One-way sign (rule 98)</p> 
<p>One-way sign (rule 98)</p> 	<p>Pedestrians may cross diagonally sign (rules 230, 234)</p> 
<p>Permissive parking sign (for a length of road) (rule 204)</p> 	<p>Permissive parking sign (for a length of road) (rule 204)</p> 
<p>Permissive parking sign (for a length of road) (rule 204)</p> 	<p>Permissive parking sign (for a length of road) (rule 204)</p> 

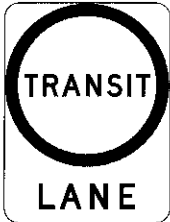
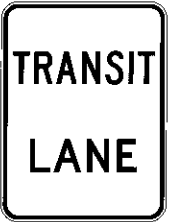
<p>Permissive parking sign (for an area) (rule 204)</p> 	<p>Permissive parking sign (for an area) (rule 204)</p> 
<p>Permissive parking sign (for an area) (rule 204)</p> 	<p>Permissive parking sign (for an area) (rule 204)</p> 
<p>Permit zone sign (rule 185)</p> 	<p>Permit zone sign (rule 185)</p> 
<p>Right lane must turn right sign (rule 89)</p> 	<p>Right turn only sign (rule 89)</p> 

<p>Right turn only sign (rule 89)</p> 	<p>Road access sign (rules 97, 229)</p> 
<p>Road access sign (rules 97, 229)</p> 	<p>Road access sign (rules 97, 229)</p> 
<p>Road access sign (rules 97, 229)</p> 	<p>School zone sign (rule 23)</p> 
<p>School zone sign (rule 23)</p> 	<p>School zone sign (rule 23)</p> 

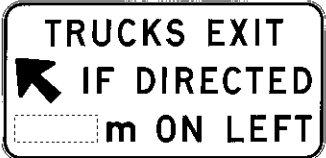
<p>School zone sign (rule 23)</p> 	<p>Separated footpath sign (rules 239, 252)</p> 
<p>Shared path sign (rules 242, 252)</p> 	<p>Shared zone sign (rule 24)</p> 
<p>Shared zone sign (rule 24)</p> 	<p>Speed-limit sign (rule 21)</p> 
<p>Stop here on red signal sign (rule 56)</p> 	<p>Taxi zone sign (rule 182)</p> 

<p>Taxi zone sign (rule 182)</p> 	<p>Taxi zone sign (rule 182)</p> 
<p>Tram lane sign (rule 155)</p> 	<p>Transit lane sign (rule 156)</p> 
<p>Transit lane sign (rule 156)</p> 	<p>Trucks and buses low gear sign (rule 108)</p> 
<p>Trucks and buses low gear sign (rule 108)</p> 	<p>Trucks must enter sign (rule 105)</p> 
<p>Trucks must enter sign (rule 105)</p> 	<p>Trucks use left lane sign (rule 159)</p> 

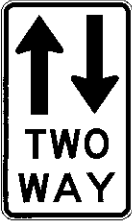
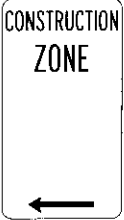



<p>Truck zone sign (rule 180)</p> 	<p>Two-way sign (rules 98, 132, 136)</p> 
<p>Works zone sign (rule 181)</p> 	





***THIS PAGE INTENTIONALLY LEFT BLANK***

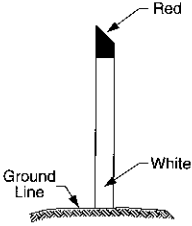
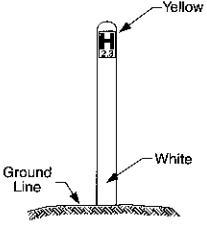
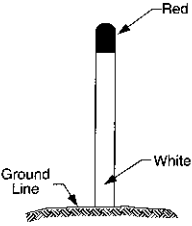

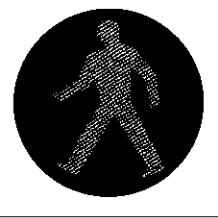
## Schedule 4 Symbols and traffic-related items

(rule 320)

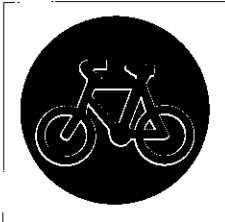
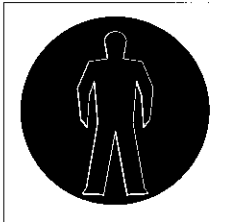
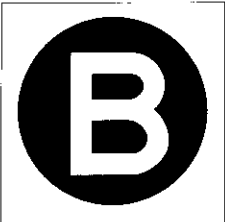
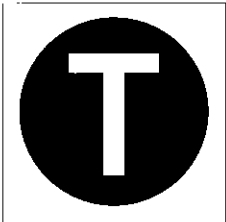
<p>Do not overtake turning vehicle sign (rules 28, 32, 143)</p> 	<p>Do not overtake turning vehicle sign (rules 28, 32, 143)</p> 
<p>Fire hydrant indicator (example) (rule 194)</p> 	<p>Fire hydrant indicator (example) (rule 194)</p> 
<p>Fire plug indicator (example) (rule 194)</p> 	<p>Give way to buses sign (rule 77)</p> 
<p>Green bicycle symbol (rule 260)</p> 	<p>Green pedestrian symbol (rule 231)</p> 

<p>People with disabilities symbol (rule 203)</p> 	<p>People with disabilities symbol (rule 203)</p> 
<p>Red bicycle symbol (rule 260)</p> 	<p>Red pedestrian symbol (rule 231)</p> 
<p>White B-light (rule 285)</p> 	<p>White T-light (rule 278)</p> 
<p>Yellow bicycle symbol (rule 261)</p> 	

## Dictionary

(rule 4)

**adjacent land**, for a road, means land next to the road (whether or not it adjoins the road), but does not include a road or road-related area.

*Note 1* **Land** includes premises or a part of premises — see the definition in this dictionary.

*Note 2* **Road** is defined in rule 12, and **road-related area** in rule 13.

**approaching**, for a driver, means approaching from any direction.

**approved bicycle helmet** means a protective helmet for bicycle riders that is approved, for the *Australian Road Rules*, under another law of this jurisdiction.

**area** includes:

- (a) a bridge; and
- (b) a network of roads; and
- (c) a slip lane.

*Note* **Slip lane** is defined in this dictionary.

**authorised person**, for a provision of the *Australian Road Rules*, means a person who is appointed under another law of this jurisdiction to be an authorised person for the Rules or the provision.

**bicycle** means a vehicle with 1 or more wheels that is built to be propelled by human power through a belt, chain or gears (whether or not it has an auxiliary motor), and:

- (a) includes a pedicab, penny-farthing, scooter, tricycle and unicycle; but
- (b) does not include a wheelchair, wheeled recreational device, wheeled toy, or any vehicle with an auxiliary motor capable of generating a power output over 200 watts (whether or not the motor is operating).

*Note* **Vehicle** is defined in rule 15, and **wheelchair**, **wheeled recreational device** and **wheeled toy** are defined in this dictionary.

**bicycle crossing light** means a green, yellow or red bicycle crossing light.

*Note* **Green bicycle crossing light**, **yellow bicycle crossing light** and **red bicycle crossing light** are defined in this dictionary.

**bicycle crossing lights** means a device designed to show a bicycle crossing light, or 2 or more bicycle crossing lights at different times.

*Note* **Bicycle crossing light** is defined in this dictionary.

**bicycle lane** see rule 153.

**bicycle path** see rule 239.

**bicycle path road marking** see rule 239.

**bicycle symbol** means a symbol consisting of a picture of a bicycle.

*Note* The symbol is, for example, used in a **bicycle lane sign**, a **bicycle path sign** and a **separated footpath sign** — see Schedule 2.

**B light** means a red, white or yellow B light.

*Note* **Red B light**, **white B light** and **yellow B light** are defined in this dictionary.

**B lights** means a device designed to show a B light, or 2 or more B lights at different times.

**built-up area**, in relation to a length of road, means an area in which there are buildings on land next to the road, or there is street lighting, at intervals not over 100 metres for a distance of at least 500 metres or, if the road is shorter than 500 metres, for the whole road.

*Note* **Length** of road is defined in this dictionary.

**bus** means a motor vehicle built mainly to carry people that seats over 12 adults (including the driver).

*Note* **Motor vehicle** is defined in this dictionary.

**bus lane** see rule 154.

**bus zone** see rule 183.

**centre of the road**, for a driver on a two-way road, means the far right side of the part of the road used by traffic travelling in the same direction as the driver.

**changes direction** see rule 45.

**children's crossing** see rule 80.

**combination** means a group of vehicles consisting of a motor vehicle connected to 1 or more vehicles.

*Note* **Motor vehicle** is defined in this dictionary, and **vehicle** is defined in rule 15.

**continuing road**, for a T-intersection, means the road (except a road-related area) that meets the terminating road at the T-intersection.

*Note* **Road-related area** is defined in rule 13, and **terminating road** and **T-intersection** are defined in this dictionary.

**crash** includes:

- (a) a collision between 2 or more vehicles; or
- (b) any other accident or incident involving a vehicle in which a person is killed or injured, property is damaged, or an animal in someone's charge is killed or injured.

*Note* **Vehicle** is defined in rule 15.

**crossing** means a children's crossing, level crossing, marked foot crossing or pedestrian crossing.

*Note* **Children's crossing** is defined in rule 80, **level crossing** is defined in rule 120, **marked foot crossing** is defined in this dictionary, and **pedestrian crossing** is defined in rule 81.

**dividing line** means a road marking formed by a line, or 2 parallel lines, whether broken or continuous, designed to indicate the parts of the road to be used by vehicles travelling in opposite directions.

*Note* **Road marking** is defined in this dictionary, and **vehicle** is defined in rule 15.

**dividing strip** means an area or structure that divides a road lengthways, but does not include a nature strip, bicycle path, footpath or shared path.

*Note* **Bicycle path** is defined in rule 239, **footpath** and **nature strip** are defined in this dictionary, and **shared path** is defined in rule 242.

**drive** includes be in control of.

**driver** see rules 16 and 19.

**driver's vehicle**, for a driver, means the vehicle being driven by the driver.

**edge line**, for a road, means a line marked along the road at or near the far left or far right side of the road (except any road-related area of the road).

**emergency stopping lane** see rule 95.

**emergency vehicle**, for a provision of the *Australian Road Rules*, means any vehicle driven by a person who is:

- (a) an emergency worker for the provision; and
- (b) driving the vehicle in the course of his or her duties as an emergency worker.

*Note 1* **Emergency worker** is defined in this dictionary, and **vehicle** is defined in rule 15.

*Note 2* **Drive** includes be in control of — see the definition in this dictionary.

**emergency worker**, for a provision of the *Australian Road Rules*, means a person who is an emergency worker for the Rules, or the provision, under another law of this jurisdiction.

**enter** an intersection or crossing, for the driver of a vehicle or a train, means enter the intersection or crossing with any part of the vehicle or train.

*Note* **Crossing** and **intersection** are defined in this dictionary, and **vehicle** is defined in rule 15.

**footpath**, except in rule 13 (1), means an area open to the public that is designated for, or has as one of its main uses, use by pedestrians.

*Note* Rule 13 defines road-related area.

**freeway** see rule 177.

**give way**, for a driver or pedestrian, means:

- (a) if the driver or pedestrian is stopped — remain stationary until it is safe to proceed; or
- (b) in any other case — slow down and, if necessary, stop to avoid a collision.

**give way line** means a broken line that is marked across all or part of a road and is not part of a marked foot crossing.

*Note 1* **Marked foot crossing** is defined in this dictionary.

*Note 2* There is an example of a give way line in rule 69.

**green bicycle crossing light** means an illuminated green bicycle symbol as shown in the diagram in Schedule 4.

*Note* **Bicycle symbol** is defined in this dictionary.

**green pedestrian light** means:

- (a) an illuminated green pedestrian symbol; or
- (b) the word 'walk' illuminated in green (whether or not flashing).

*Note* **Green pedestrian symbol** is defined in this dictionary.

**green pedestrian symbol** means a symbol consisting of a picture of a pedestrian as shown in the diagram in green in Schedule 4.

**green traffic arrow** means an illuminated green arrow.

**green traffic light** means an illuminated green disc.

**GVM**, for a vehicle, means the maximum loaded mass of the vehicle:

- (a) specified by the manufacturer on an identification plate on the vehicle; or
- (b) if there is no specification by the manufacturer on an identification plate on the vehicle or if the specification is not appropriate because the vehicle has been modified — certified by a vehicle registration authority.

*Note* **Vehicle** is defined in rule 15.

**halfway around**, for a roundabout, see rule 110.

**hazard warning lights** means a pair of yellow direction indicator lights fitted to a vehicle under another law of this jurisdiction that display regular flashes of light at the same time, and at the same rate, as each other, but does not include warning lights fitted, under another law of this jurisdiction, to a bus used for carrying children.

*Note* **Bus** is defined in this dictionary, and **vehicle** is defined in rule 15.

**high-beam**, for a headlight fitted to a vehicle, means that the headlight is built or adjusted so, when the vehicle is standing on level ground, the top of the main beam of light projected is above the headlight's low-beam.

*Note* **Low-beam** is defined in this dictionary, and **vehicle** is defined in rule 15.

**hook turn** see rules 34 and 35.

**intersection** means the area where 2 or more roads (except any road-related area) meet, and includes:

- (a) any area of the roads where vehicles travelling on different roads might collide; and
- (b) the area of any slip lane where the roads meet;

but does not include any road-related area.

*Note* **Road** is defined in rule 12, **road-related area** is defined in rule 13, **slip lane** is defined in this dictionary, and **vehicle** is defined in rule 15.

**keep clear marking** see rule 96.

**land** includes premises or a part of premises.

**left**, for a person or in relation to something, see rule 351 (1) and (3).

**left change of direction signal** means a change of direction signal given in accordance with rule 47.

**left traffic lane arrows** means traffic lane arrows applying to a marked lane that indicate only a direction to the left.

*Note* **Marked lane** and **traffic lane arrows** are defined in this dictionary.

**length**, of road, includes:

- (a) a marked lane or a part of a marked lane; and
- (b) another part of a length of road.

*Note* **Marked lane** is defined in this dictionary.

**level crossing** see rule 120.

**loading zone** see rule 179.

**low-beam**, for a headlight fitted to a vehicle, means that the headlight is built or adjusted so, when the vehicle is standing on level ground, the top of the main beam of light projected is:

- (a) not higher than the centre of the headlight, when measured 8 metres in front of the vehicle; and
- (b) not over 1 metre higher than the level where the vehicle is standing, when measured 25 metres in front of the vehicle.

*Note* **Vehicle** is defined in rule 15.

**mail zone** see rule 186.

**marked foot crossing** means an area of a road:

- (a) at a place with pedestrian lights facing pedestrians crossing the road and traffic lights facing vehicles driving on the road; and
- (b) indicated by a different road surface, or between 2 parallel continuous or broken lines, or rows of studs or markers, on the road surface substantially from one side of the road to the other.

*Example of a different road surface*

The area of road could be indicated by brick paving across a bitumen road.

*Note* **Pedestrian lights** and **traffic lights** are defined in this dictionary, and **vehicle** is defined in rule 15.

**marked lane** means an area of a road marked by continuous or broken lines, or rows of studs or markers, on the road surface that is designed for use by a single line of vehicles.

*Note* **Vehicle** is defined in rule 15.

**mechanical signalling device** means a device that is declared to be a mechanical signalling device for the *Australian Road Rules* under another law of this jurisdiction.

**median strip** means a dividing strip designed or developed to separate vehicles travelling in opposite directions.

*Note* **Dividing strip** is defined in this dictionary, and **vehicle** is defined in rule 15.

**median strip parking area** means a parking area on or in a median strip.

*Note* **Parking area** is defined in this dictionary.

**minibus zone** see rule 184.

**motor bike** means a motor vehicle with 2 wheels, and includes:

- (a) a 2-wheeled motor vehicle with a sidecar attached to it that is supported by a third wheel; and
- (b) a motor vehicle with 3 wheels that is ridden in the same way as a motor vehicle with 2 wheels.

**motor vehicle** means a vehicle that is built to be propelled by a motor that forms part of the vehicle.

**multi-lane road**, for a driver, means a one-way road, or a two-way road, with 2 or more marked lanes (except bicycle lanes) that are:

- (a) on the side of the dividing line or median strip where the driver is driving; and
- (b) for the use of vehicles travelling in the same direction.

*Note* **Bicycle lane** is defined in rule 153, **dividing line**, **marked lane**, **median strip**, **one-way road** and **two-way road** are defined in this dictionary, and **vehicle** is defined in rule 15.

**nature strip**, except in rule 13 (1), means an area between a road (except a road-related area) and adjacent land, but does not include a bicycle path, footpath or shared path.

*Note 1* **Adjacent land** and **footpath** are defined in this dictionary, **bicycle path** is defined in rule 239, **road** is defined in rule 12, and **shared path** is defined in rule 242.

*Note 2* Rule 13 defines a road-related area.

**night** means the period between sunset on one day and sunrise on the next day.

**no bicycles road marking** means a road marking consisting of a bicycle symbol with a diagonal line across it, or the words 'no bicycles', or both the symbol and the words.

*Note* **Bicycle symbol** and **road marking** are defined in this dictionary.

**obstruction** includes a traffic hazard, but does not include a vehicle only because the vehicle is stopped in traffic or is travelling more slowly than other vehicles.

*Note* **Vehicle** is defined in rule 15.

**oncoming vehicle**, for a driver, means a vehicle approaching the driver travelling in the opposite direction to the direction in which the driver is driving.

*Note* **Vehicle** is defined in rule 15.

**one-way road** means a road with 1 or more marked lanes, all of which are for the use of vehicles travelling in the same direction.

*Note* **Marked lane** is defined in this dictionary, and **vehicle** is defined in rule 15.

**overhead lane control device** means an overhead lane control sign or signal.

**overhead lane control sign** means a traffic sign displaying a red diagonal cross that is installed on a structure over a road or part of a road.

*Note* **Traffic sign** is defined in this dictionary.

**overhead lane control signal** means:

- (a) an illuminated red diagonal cross (whether or not flashing); or
- (b) an illuminated white, green or yellow arrow pointing downwards or indicating 1 or more directions.

**overhead lane control signals** means a device on a structure over a road, or part of a road, that is designed to display an overhead lane control signal, or 2 or more overhead lane control signals.

**oversize vehicle** means a vehicle that is declared to be an oversize vehicle for the *Australian Road Rules* under another law of this jurisdiction.

*Note* **Vehicle** is defined in rule 15.

**overtake**, for a driver, means the action of:

- (a) approaching from behind another driver travelling in the same marked lane or line of traffic; and
- (b) moving into an adjacent marked lane or line of traffic (whether or not the lane or line of traffic is for drivers travelling in the same direction); and
- (c) passing the other driver while travelling in the adjacent marked lane or line of traffic.

*Note* **Marked lane** is defined in this dictionary.

**painted island** means an area of a road, surrounded by a line or lines (whether broken or continuous), on which there are stripes marked on the road surface in white or another colour contrasting with the colour of the road.

**park**, in Part 12 and for a driver, includes stop and allow the driver's vehicle to stay (whether or not the driver leaves the vehicle).

*Note 1* **Driver's vehicle** is defined in this dictionary.

*Note 2* Part 12 deals with restrictions on stopping and parking.

**parking area** means a length of road or area designed for parking vehicles.

*Note* **Vehicle** is defined in rule 15.

**Parking area for people with disabilities** see rule 203.

**parking bay** means an area for parking a single vehicle (other than a combination) that is indicated by:

- (a) road markings consisting of lines, studs or other similar devices; or
- (b) a different road surface.

*Note* **Combination** and **road marking** are defined in this dictionary, and **vehicle** is defined in rule 15.



**parking control sign** means any of the following:

- (a) a *bicycle parking sign*;
- (b) a *bus zone sign*;
- (c) a *clearway sign*;
- (d) a *loading zone sign*;
- (e) a *mail zone sign*;
- (f) a *minibus zone sign*;
- (g) a *motor bike parking sign*;
- (h) a *no parking sign*;
- (i) a *no stopping sign*;
- (j) a *people with disabilities parking sign*;
- (k) a *permissive parking sign*;
- (l) a *permit zone sign*;
- (m) a *taxi zone sign*;
- (n) a *truck zone sign*;
- (o) a *works zone sign*.

**parking permit for people with disabilities** means a permit, issued under another law of this jurisdiction or the law of another jurisdiction, that includes a people with disabilities symbol.

*Note* **People with disabilities symbol** is defined in this dictionary.

**part of the road used by the main body of moving vehicles** means the area of the road, except:

- (a) any road-related area; and
- (b) if the road has 1 or more service roads — the area of any service road.

*Note 1* **Road-related area** is defined in rule 13, and **service road** is defined in this dictionary.

*Note 2* A road-related area includes any shoulder of the road — see rule 13.

**pedestrian** see rule 18.

**pedestrian crossing** see rule 81.

**pedestrian lights** means a device designed to show, at different times, a green or red pedestrian light.

*Note* **Green pedestrian light** and **red pedestrian light** are defined in this dictionary.

**pedestrian symbol** means a symbol consisting of a picture of a pedestrian.

*Note* The symbol is, for example, used in a *separated footpath sign* — see Schedule 2.

**people with disabilities road marking** see rule 203.

**people with disabilities symbol** means a picture of a person seated in a wheelchair as shown in the diagrams in Schedule 4.

**permit zone** see rule 185.

**police officer**, for a provision of the *Australian Road Rules*, means a person who is a police officer for the Rules, or the provision, under another law of this jurisdiction.

**police vehicle**, for a provision of the *Australian Road Rules*, means any vehicle driven by a person who is:

- (a) a police officer for the provision; and
- (b) driving the vehicle in the course of his or her duties as a police officer.

*Note 1* **Police officer** is defined in this dictionary, and **vehicle** is defined in rule 15.

*Note 2* **Drive** includes be in control of — see the definition in this dictionary.

**portable warning triangle** means a portable warning triangle approved, for the *Australian Road Rules*, under another law of this jurisdiction.

**postal vehicle**, for a provision of the *Australian Road Rules*, means a vehicle driven by a person who is:

- (a) a postal worker for the provision; and
- (b) driving the vehicle in the course of his or her duties as a postal worker.

*Note 1* **Postal worker** is defined in this dictionary, and **vehicle** is defined in rule 15.

*Note 2* **Drive** includes be in control of — see the definition in this dictionary.

**postal worker**, for a provision of the *Australian Road Rules*, means a person who is a postal worker for the Rules, or the provision, under another law of this jurisdiction.

**public bus**, for a provision of the *Australian Road Rules*, means a vehicle that is declared to be a public bus for the Rules, or the provision, under another law of this jurisdiction.

*Note* **Vehicle** is defined in rule 15.

**public holiday**, for a place, means a public holiday at the place under the law of this jurisdiction.

**public minibus**, for a provision of the *Australian Road Rules*, means a vehicle that is declared to be a public minibus for the Rules, or the provision, under another law of this jurisdiction.

*Note* **Vehicle** is defined in rule 15.

**red bicycle crossing light** means an illuminated red bicycle symbol (whether or not flashing) as shown in the diagram in Schedule 4.

*Note* **Bicycle symbol** is defined in this dictionary.

**red B light** means an illuminated red B.

**red pedestrian light** means:

- (a) an illuminated red pedestrian symbol (whether or not flashing); or
- (b) the words 'dont walk' illuminated in red (whether or not flashing).

*Note* **Red pedestrian symbol** is defined in this dictionary.

**red pedestrian symbol** means a symbol consisting of a picture of a pedestrian as shown in the diagram in red in Schedule 4.

**red T light** means an illuminated red T.

**red traffic arrow** means an illuminated red arrow.

**red traffic light** means an illuminated red disc.

**ride**, for the rider of a motor bike or animal-drawn vehicle, includes be in control of.

*Note* **Motor bike** is defined in this dictionary.

**rider** see rule 17.

**right**, for a person or in relation to something, see rule 351 (2) and (3).

**right change of direction signal** means a change of direction signal given in accordance with rule 49.

**right traffic lane arrows** means traffic lane arrows applying to a marked lane that indicate only a direction to the right.

*Note* **Marked lane** and **traffic lane arrows** are defined in this dictionary.

**road** see rules 11 (2) and 12.

**road marking** means a word, figure, symbol, mark, line, raised marker or stud, or something else, on the surface of a road to direct or warn traffic, but does not include a painted island.

*Note* **Painted island** is defined in this dictionary.

**road-related area** see rule 13.

**road user** see rule 14.

**roundabout** see rule 109.

**safety zone** see rule 162.

**school zone** see rule 23.

**separated footpath** see rule 239.

**separated footpath road marking** see rule 239.

**service road** means the part of a road that:

- (a) is separated from other parts of the road by a dividing strip that is not designed or developed, wholly or mainly, to separate vehicles travelling in opposite directions; and
- (b) is:
  - (i) designed or developed to be used, wholly or mainly, by traffic servicing adjacent land; or
  - (ii) indicated to be a service road by information on or with a traffic control device on the road.

*Note* **Adjacent land**, **dividing strip**, **traffic**, **traffic control device** and **with** are defined in this dictionary, and **vehicle** is defined in rule 15.

**shared path** see rule 242.

**shared zone** see rule 24.

**shoulder** see rule 12.

**slip lane** means an area of road for vehicles turning left that is separated, at some point, from other parts of the road by a painted island or traffic island.

*Note* **Painted island** and **traffic island** are defined in this dictionary, and **vehicle** is defined in rule 15.

**special purpose lane** means a marked lane, or the part of a marked lane, that is a bicycle lane, bus lane, emergency stopping lane, tram lane, transit lane or truck lane.

*Note* **Bicycle lane** is defined in rule 153, **bus lane** is defined in rule 154, **emergency stopping lane** is defined in rule 95, **marked lane** is defined in this dictionary, **tram lane** is defined in rule 155, **transit lane** is defined in rule 156, and **truck lane** is defined in rule 157.

**speed-limited area** see rule 22.

**stop**, in Part 12 and for a driver, includes park, but does not include stop to reverse the driver's vehicle into a parking bay or other parking space.

*Note 1* **Driver's vehicle**, **park** and **parking bay** are defined in this dictionary.

*Note 2* Part 12 deals with restrictions on stopping and parking.

**stop line** means a continuous line that:

- (a) is marked across all or part of a road; and
- (b) is not part of a marked foot crossing or a keep clear marking.

*Note 1* **Keep clear marking** is defined in rule 96, and **marked foot crossing** is defined in this dictionary.

*Note 2* There is an example of a stop line in rule 67.

**straight ahead** includes substantially straight ahead.

**T-intersection** means an intersection where 2 roads meet (whether or not at right angles) and one of the roads ends.

*Note* **Intersection** is defined in this dictionary.

**T light** means a red, white or yellow T light.

*Note* **Red T light**, **white T light** and **yellow T light** are defined in this dictionary.

**T lights** means a device designed to show a T light, or 2 or more T lights at different times.

**taxi**, for a provision of the *Australian Road Rules*, means a vehicle that is declared to be a taxi for the Rules, or the provision, under another law of this jurisdiction.

*Note* **Vehicle** is defined in rule 15.

**taxi zone** see rule 182.

**terminating road**, for a T-intersection, means:

- (a) if a road (except a road related area) at the intersection is designated by traffic signs or road markings, or in another way, as a road that ends at the intersection — that road; or
- (b) in any other case — a road (except a road-related area) that ends at the intersection.

*Note* **Road** is defined in rule 12, **road-related area** is defined in rule 13, and **T-intersection** is defined in this dictionary.

**tractor** does not include a motor vehicle built to tow a semi-trailer.

*Note* **Motor vehicle** is defined in this dictionary.

**traffic** includes vehicles and pedestrians.

*Note* **Pedestrian** is defined in rule 18, and **vehicle** is defined in rule 15.

**traffic arrow** means a green, white or red traffic arrow, or a yellow traffic arrow (whether or not flashing).

*Note* **Green traffic arrow**, **red traffic arrow**, **white traffic arrow** and **yellow traffic arrow** are defined in this dictionary.

**traffic arrows** means a device installed with traffic lights that is designed to show a traffic arrow, or 2 or more traffic arrows at different times.

**traffic control device** means a traffic sign, road marking, traffic signals, or other device, to direct or warn traffic on, entering or leaving a road.

*Note* Various terms used in this definition are defined in this dictionary.

**traffic island** means a structure on a road to direct traffic, but does not include a road marking or painted island.

*Note* **Painted island** and **road marking** are defined in this dictionary.

**traffic lane arrows** means a traffic sign, road marking or device that displays arrows indicating 1 or more directions and is designed to apply to 1 or more marked lanes, but does not include traffic arrows.

*Note* **Marked lane**, **road marking**, **traffic arrow** and **traffic sign** are defined in this dictionary.

**traffic light** means a green traffic light, or a red or yellow traffic light (whether or not flashing).

*Note* **Green traffic light**, **red traffic light** and **yellow traffic light** are defined in this dictionary.

**traffic lights** means a device designed to show a traffic light, or 2 or more traffic lights in a vertical arrangement and at different times, and includes any traffic arrows installed with or near the device.

**traffic lights pole** means a pole or other structure on which traffic lights are installed.

**traffic-related item** means any of the following:

- (a) a *do not overtake turning vehicle sign*;
- (b) a *give way to buses sign*;
- (c) a fire hydrant indicator or fire plug indicator.

*Note* Examples of a fire hydrant indicator and fire plug indicator are shown in Schedule 4.

**traffic sign** means a board, plate, screen, or another device, whether or not illuminated, displaying words, figures, symbols or anything else to direct or warn traffic on, entering or leaving a road, and includes a children crossing flag, a *hand-held stop sign*, a parking control sign and a variable illuminated message sign, but does not include traffic signals.

*Note* Various terms used in this definition are defined in this dictionary.

**traffic signals** means bicycle crossing lights, B lights, overhead lane control signals, pedestrian lights, T lights, traffic arrows, traffic lights or twin red or yellow lights.

*Note* Various terms used in this definition are defined in this dictionary.

**trailer** means a vehicle that is built to be towed, or is towed, by a motor vehicle, but does not include a motor vehicle that is being towed.

*Note* **Motor vehicle** is defined in this dictionary, and **vehicle** is defined in rule 15.

**tram** includes a light rail vehicle.

**tram lane** see rule 155.

**tram tracks** includes a rail designed for a light rail vehicle to run on.

**transit lane** see rule 156.

**travelling along tram tracks**, for a bus, means being driven along the area where the tram tracks are laid.

*Note* **Bus** and **tram tracks** are defined in this dictionary.

**trolley** includes a shopping trolley and any other kind of handcart.

**truck** means a motor vehicle with a GVM over 4.5 tonnes, except a bus, tram or tractor.

*Note* **Bus**, **GVM**, **motor vehicle**, **tram** and **tractor** are defined in this dictionary.

**truck lane** see rule 157.

**truck zone** see rule 180.

**turning lane** means a marked lane, or the part of a marked lane, for vehicles travelling in one direction to which:

- (a) a *left turn only sign*, a *left lane must turn left sign* or left traffic lane arrows apply; or
- (b) a *right turn only sign*, a *right lane must turn right sign* or right traffic lane arrows apply.

*Note* **Left traffic lane arrows**, **marked lane** and **right traffic lane arrows** are defined in this dictionary, and **vehicle** is defined in rule 15.

**twin red lights** means a device showing, in a horizontal or diagonal arrangement, 2 illuminated red discs that flash alternately.

**twin yellow lights** means a device showing, in a horizontal or diagonal arrangement, 2 illuminated yellow discs that flash alternately.

**two-way road** means a road for use by vehicles travelling in opposite directions.

*Note* **Vehicle** is defined in rule 15.

**U-turn** means a turn made by a driver so that the driver's vehicle faces in approximately the opposite direction from which it was facing immediately before the turn was made, but does not include a turn made at a roundabout.

*Note* **Driver's vehicle** is defined in this dictionary, and **roundabout** is defined in rule 109.

**variable illuminated message device** means a device designed to display, and to change or turn off from time to time by electronic or optical means, illuminated words, figures, symbols, or anything else, to direct or warn traffic on, entering or leaving a road, but does not include traffic signals.

*Note* **Traffic** is defined in this dictionary.

**variable illuminated message sign** means the illuminated words, figures, symbols, or other things, displayed at any relevant time on a variable illuminated message device.

**vehicle** see rule 15.

**wheelchair** means a chair mounted on 2 or more wheels that is built to transport a person who is unable to walk or has difficulty in walking, but does not include a pram, stroller or trolley.

*Note* **Trolley** is defined in this dictionary.

**wheeled recreational device** means a wheeled device, built to transport a person, propelled by human power or gravity, and ordinarily used for recreation or play, and:

- (a) includes rollerblades, rollerskates, a skateboard or similar wheeled device; but
- (b) does not include a golf buggy, pram, stroller or trolley, or a bicycle, wheelchair or wheeled toy.

*Note* **Bicycle, trolley, wheelchair** and **wheeled toy** are defined in this dictionary.

**wheeled toy** means a child's pedal car, scooter or tricycle or a similar toy, but only when it is being used only by a child who is under 12 years old.

**white B light** means an illuminated white B as shown in the diagram in Schedule 4.

**white T light** means an illuminated white T as shown in the diagram in Schedule 4.

**white traffic arrow** means an illuminated white arrow.

**with**, for information about the application of a traffic control device, includes accompanying or reasonably associated with the device.

**works zone** see rule 181.

**yellow bicycle crossing light** means an illuminated yellow bicycle symbol (whether or not flashing) as shown in the diagram in Schedule 4.

*Note* **Bicycle symbol** is defined in this dictionary.

**yellow B light** means an illuminated yellow B.

**yellow T light** means an illuminated yellow T.

**yellow traffic arrow** means an illuminated yellow arrow.

**yellow traffic light** means an illuminated yellow disc.